SRC-XS and SRC-S series compressors

Summary
(SA-00-10-E)

SA0102E	GENERAL
SA0207E	LUBRICATION
SA0304E	CAPACITY CONTROL
SA0407E	COMPONENTS
SA0510E	ELECTRICAL DEVICES
SA0608E	MODEL DESIGNATION AND TECHNICAL DATA
SA0703E	EXTENT OF DELIVERY
SA0805E	DIMENSIONAL DRAWINGS
SA0903E	PERFORMANCE DATA
SA1003E	APPLICATION RANGE
SA1105E	ADDITIONAL COOLING
SA1204E	ECONOMISER
SA1303E	OPERATING INSTRUCTIONS
SA1403E	MAINTENANCE
SA1503E	CAPACITY CONTROL CONVERSION

SRC-XS and SRC-S series compressors

General

(SA-01-02-E)

1. GENERAL	2
1.1 INTRODUCTION	2
1.2 THE COMPRESSION PROCESS	4
1.3 THE ROTORS	5
1.4 THE BUILT-IN VOLUMETRIC RATIO	6

1. General

1.1 Introduction

The RefComp SRC-S and SRC-XS series screw compressors are helical twin screw oil-injected compressors (Picture 1-A shows an example with all the main parts and assemblies). The compressors feature a semi-hermetic construction, and are fitted with a three-phase asynchronous two-pole motor (2900 rpm at 50 Hz) directly coupled to the male rotor, which in turn drives the female rotor. These compressors are fitted out with a high-efficiency oil separator, whose position is different depending on the series (see chapter SA-02: “*Lubrication*”) and that allows the compressors to be installed in the refrigerant circuit without requiring any additional components. The motor is cooled by the intake gas that flows through special holes and grooves.

For the SRC-S series the capacity control is achieved by using a slide valve, which is moved by a hydraulic piston and which ensures part load operation by controlling the suction volume. For the SRC-XS series the capacity control is provided by a by-pass system, instead. In fact in these compressors part of the refrigerant mass flow is by-passed towards the suction side by suitable cylinders controlled by the refrigerant pressure.

The compressors of the SRC-XS and SRC-S series can operate with R22, R407C, R134a, R404A and R507 refrigerants.

The compactness, low noise, efficiency, completeness of the ranges and their simple installation make these series compressors ideal for the construction of a range of high-efficiency and modern water/water and air/water chillers and heat pumps. Moreover the SRC-XS series is specifically characterized by a high compactness because of the lateral oil separator, which in the SRC-S series is frontal, instead.

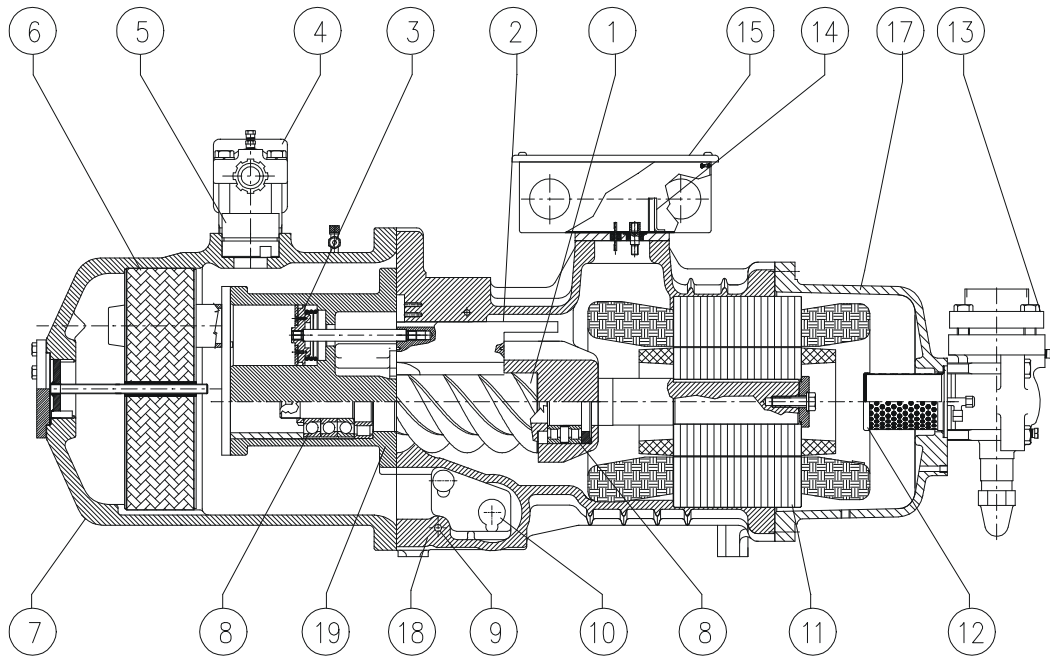

- | | | | |
|---|---|----|------------------------------------|
| 1 | Rotors; | 9 | Crankcase heater; |
| 2 | Slide valve for capacity control (only for SRC-S series); | 10 | Oil filter; |
| 3 | Slide valve control piston (only for SRC-S series); | 11 | Electrical motor; |
| 4 | Discharge shut off valve; | 12 | Suction filter; |
| 5 | Check valve; | 13 | Suction shut off valve; |
| 6 | Oil separator “Demister” (lateral position in the SRC-XS series compressors); | 14 | Motor protection device; |
| 7 | Oil reservoir / separator; | 15 | Terminal box; |
| 8 | Rolling bearings; | 17 | Suction bell; |
| | | 18 | Rotor housing; |
| | | 19 | Bearings housing (discharge side). |

Picture 1-A: Schematic drawing of an SRC-S series compact screw compressor;

1.2 The compression process

The rotors are housed inside horizontal cylindrical chambers, fitted with a suction port (on the electric motor side) and a discharge port (on the oil separator side). Tightness against leakage through the extremely reduced clearance between the rotors and the chambers is guaranteed by a film of oil that is injected directly onto the screw profile.

The compression process essentially involves the following three phases (for reasons of clarity, the following description is limited to one lobe on the male rotor and one flute on the female rotor):

- **Suction**

With reference to picture 1-B, when the lobe on the male rotor is unmeshed from the flute on the female rotor, the suction port opens into the compression chamber and, due to the rotation of the screws, the suction volume increases, creating negative pressure that draws in the refrigerant fluid. The suction phase ends when, due to rotation, the suction port is closed.

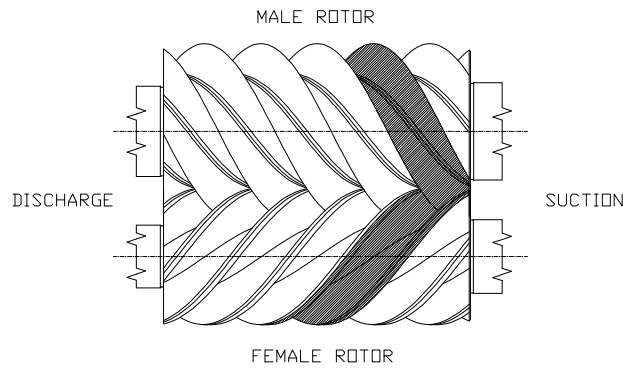

Picture 1-B: chamber at the end of the suction phase;

- **Compression**

With reference to picture 1-C, as rotation continues in the compression chamber, both the suction and the discharge ports are closed, the volume inside the chamber progressively decreases and the trapped gas moves in the longitudinal direction of the rotors, towards the discharge port. In other words, the trapped gas is compressed.

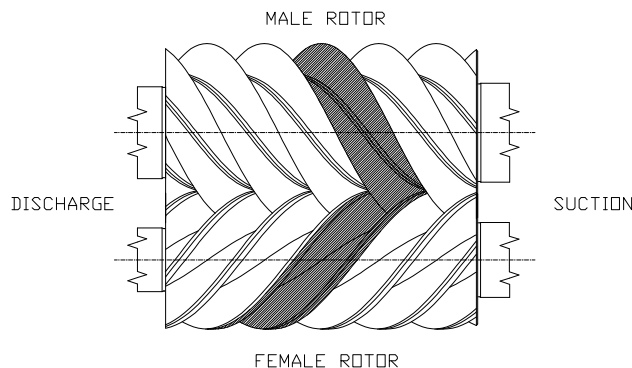

Picture 1-C: chamber during the compression phase;

• **Discharge**

With reference to picture 1-D, the rotation continues until the discharge port opens and the compressed gas is completely expelled, due to the progressive intermeshing of the lobe and the flute. As the gear ratio is 5/6 (5 lobes on the male rotor and 6 flutes on the female rotor) and the rotation speed is around 3000 rpm at 50Hz (asynchronous motor), each minute there will be $3000 \times 5 = 15000$ discharge cycles, which means an almost complete absence of pulsation at the discharge. A reciprocating compressor operating at 1500 rpm would require 10 cylinders to achieve the same result.

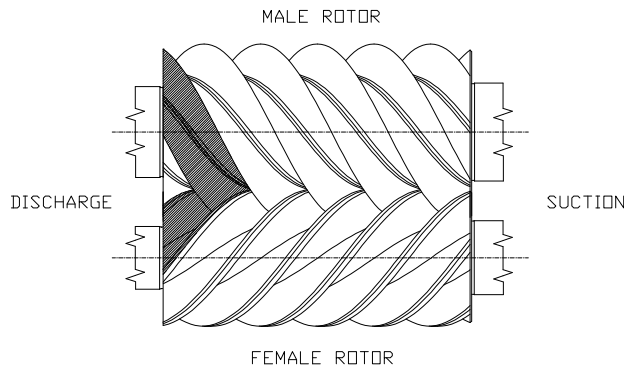

Picture 1-D: chamber at the start of the discharge phase;

1.3 The rotors

The rotors, see picture 1-E, have an asymmetrical shape with 5 lobes and 6 flutes, and are made entirely by RefComp. The perfect intermeshing between the suitably lubricated rotors ensures extremely smooth and silent compressor operation. The picture shows also the correct directions of rotation.

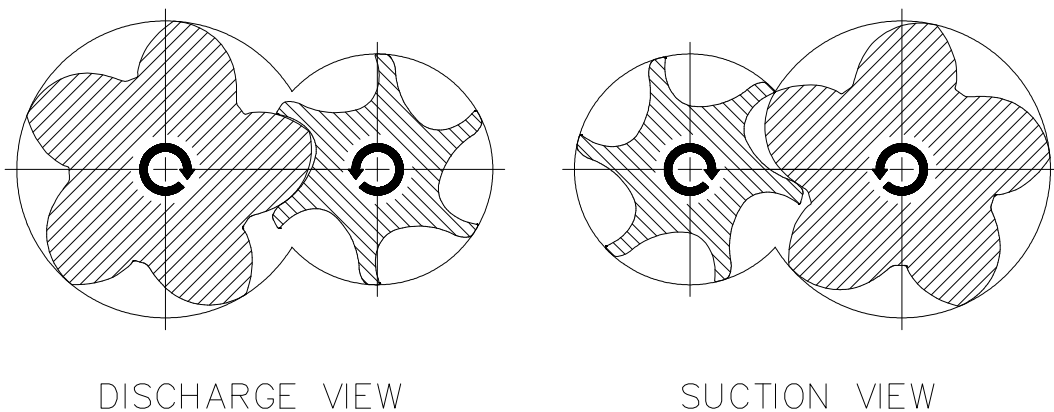

Picture 1-E: view of the rotors and correct direction of rotation;

1.4 The built-in volumetric ratio

The size and the shape of the discharge port determine the value of the so-called “ V_i ”: the “built in volumetric ratio”, defined as the ratio between the volume of the gas at the start and the end of the compression process. This ratio does not depend on the operating conditions, but rather corresponds, according to the type of refrigerant gas, to a precise compression ratio between the compressor discharge pressure and suction pressure. When this compression ratio coincides with the ratio between the condensing pressure and the evaporation pressure, the compression process is running at maximum efficiency. Indeed, the gas discharged from the compression chamber is at the same pressure of the compressor outlet (condensing pressure) and the work required to compress the gas is minimum. When, on the other hand, the pressure at the outlet differs from the discharge pressure of the gas from the rotors, there is over compression or under compression (instantaneous when the discharge port opens), which means a waste of energy, see picture 1-F.

Therefore, the choice of the most appropriate “ V_i ” ratio to suit the application ensures that energy wastage can be avoided or at least minimised.

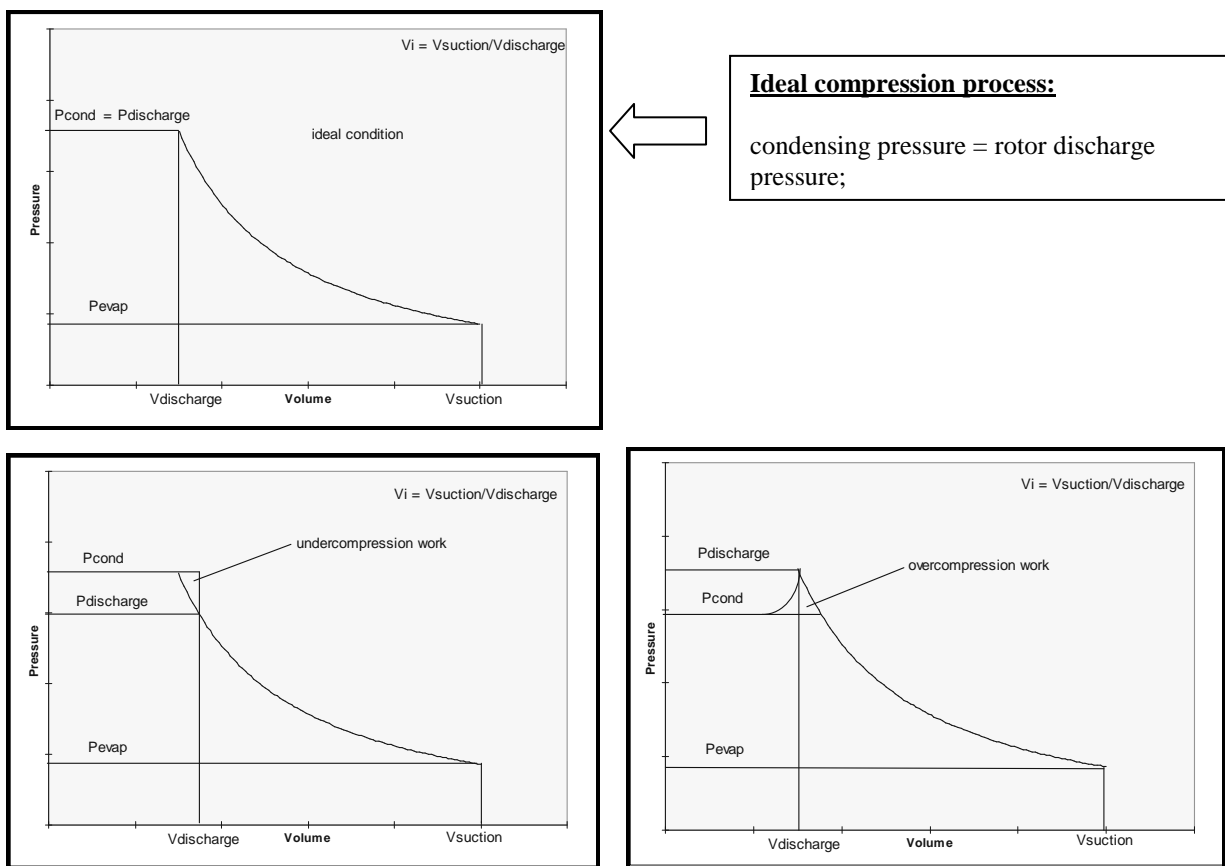

Picture 1-F: the compression process on the p-V diagram;

As standard, RefComp uses a V_i ratio in the SRC-S series compressors that is optimised for water/water or water/air chiller applications, featuring low compression ratios. Consequently, to maximise the compression efficiency in special applications with high pressure ratios (tropicalized chillers, heat pumps), the SRC-S series compressors are also available with higher “ V_i ” ratios.

The SRC-S series compressors thus have the following built-in volumetric ratio:

- ✓ **$V_i = 2.6$: “SS” models;**
- ✓ **$V_i = 3.2$: “SH” models;**

But the SRC-XS series is characterized by one built-in volumetric ratio $V_i = 2.6$, instead.

The following diagrams show the recommended fields of application for the two built-in volumetric ratios (V_i) of the SRC-S series. These fields are expressed according to the condensing and evaporating temperatures of the specific used refrigerant:

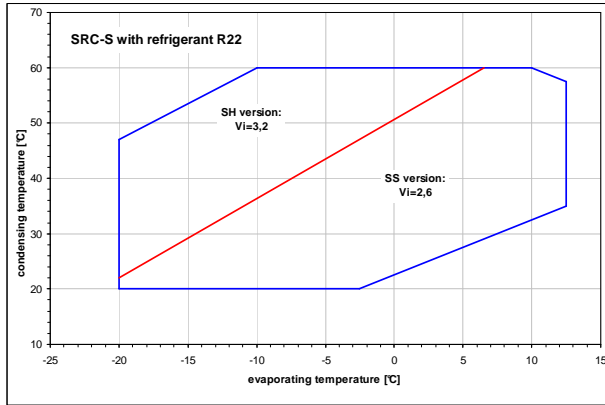

Picture 1-G: V_i values recommended by RefComp when using R22 refrigerant;

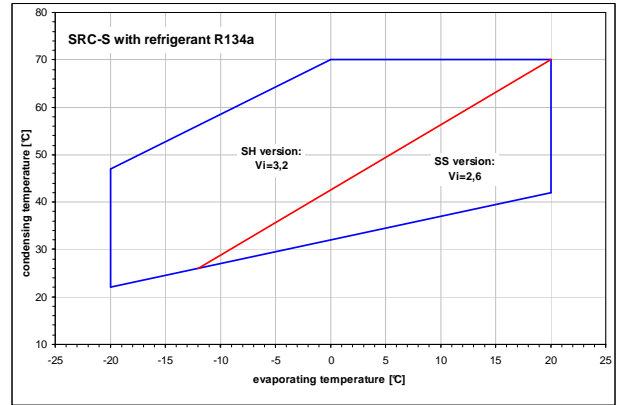

Picture 1-H: V_i values recommended by RefComp when using R134a refrigerant;

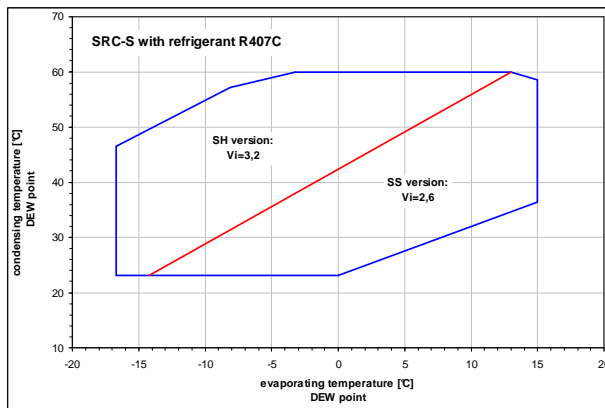

Picture 1-I: V_i values recommended by RefComp when using R407C refrigerant;

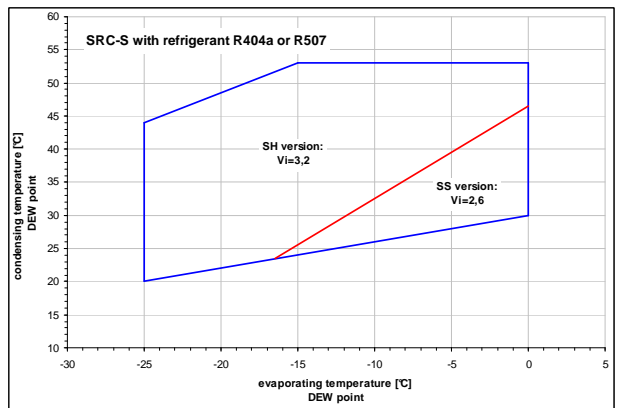

Picture 1-L: V_i values recommended by RefComp when using R404A or R507refrigerant;

SRC-XS and SRC-S compressors series
Lubrication
(SA-02-08-E)

2. LUBRICATION	2
2.1 OIL CIRCUIT	2
2.2 OIL FLOW-RATE	4
2.3 LUBRICANTS	5
2.3.1 <i>Lubricant for HCFC: R22</i>	5
2.3.2 <i>Lubricant for HFC: R407C, R134a, R404A and R507</i>	5
2.4 OIL SEPARATION	6
2.5 OIL FILTER	7
2.6 OIL HEATER	8
2.7 OIL LEVEL	9
2.8 LUBRICATION MONITORING	11

2. Lubrication

2.1 Oil circuit

The oil carries out the following functions:

- ✓ Dynamic seal between the rotors and the cylindrical chambers;
- ✓ Lubrication of the bearings and the rotors;
- ✓ Control of the slide valve for capacity control (only for the SRC-S series);
- ✓ Cooling.

Illustrative examples of the SRC-S series internal oil circuits are those shown in the cross sections of the following pictures. As regards the internal oil circuit of the SRC-XS series, the oil is still delivered to the rotors and to the bearings, but no oil system takes part in the capacity control. Therefore in the SRC-XS compressors the part of the oil circuit applied to the capacity control of the SRC-S series is absent.

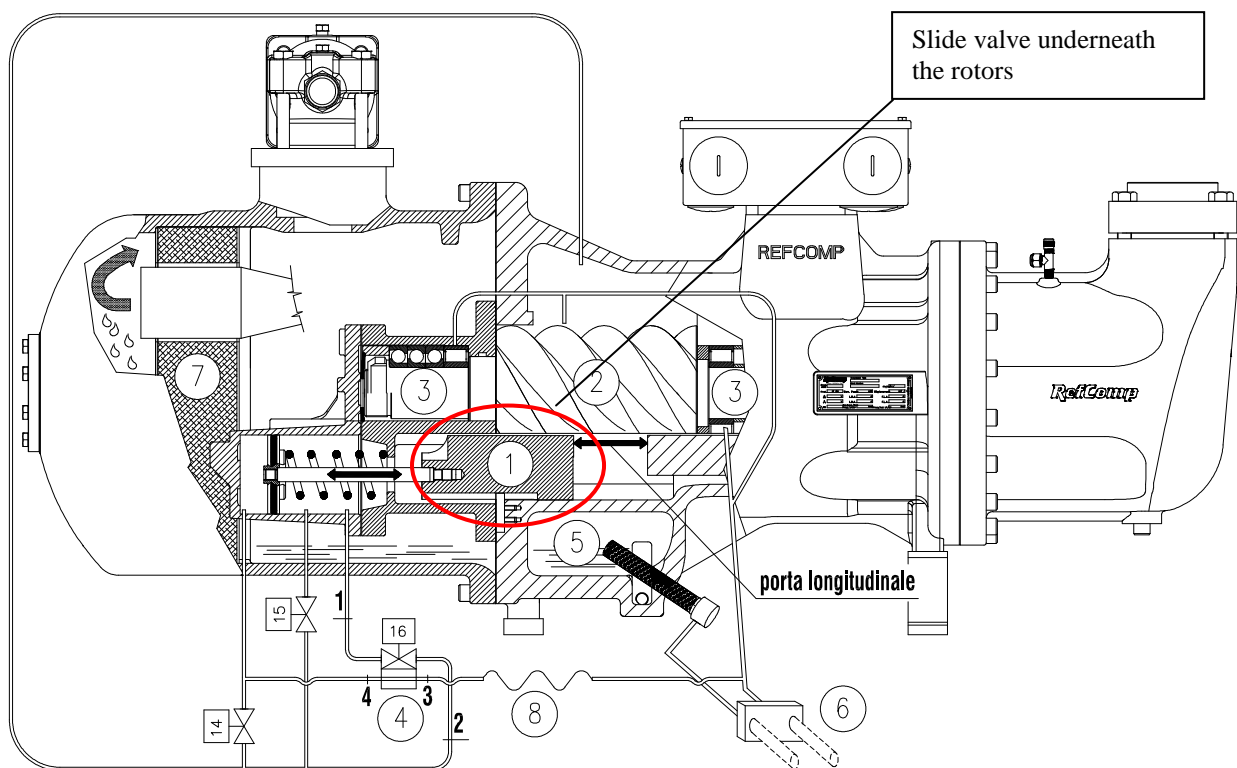

Picture 2-A: diagram of the internal oil circuit for lubrication and operation of the slide valve;

- 14,15,16: solenoid valves for capacity control;**
- 1: slide valve and actuator piston for capacity control;**
- 2: rotors;**
- 3: rolling bearings;**
- 4: plate for changing from step to stepless configuration, and vice versa;**
- 5: oil filter;**
- 6: oil inlet-outlet connection for the external cooling circuit;**
- 7: oil separator: “DEMISTER”;**
- 8: capillary tube (internal of the compressor).**

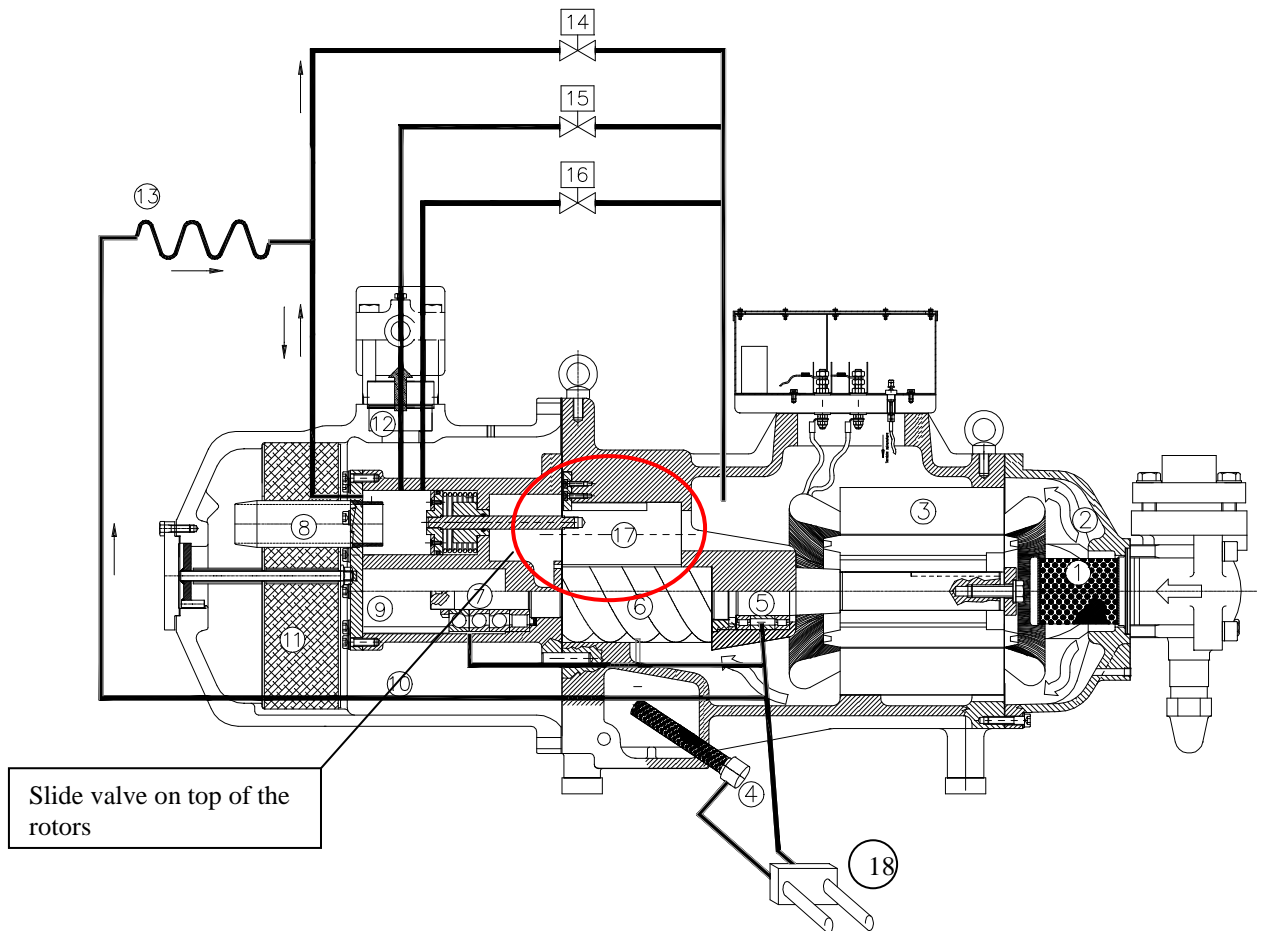

Picture 2-B: diagram of the internal oil circuit for lubrication and operation of the slide valve;
14, 15, 16: solenoid valves for capacity control;
17: slide valve and actuator piston for capacity control;
6: rotors;
5, 7: rolling bearings;
4: oil filter;
18: oil inlet-outlet connection for the external cooling circuit;
11; oil separator ‘DEMISTER’;
13; capillary tube (external of the compressor);

The lubricant is held in the bottom of the housing and in the oil separator. As shown in pictures 2-A and 2-B, the oil separator of the SRC-S compressors is connected directly to the front of the compressor flanged casing; while for the SRC-XS compressors it is located laterally making it possible to reduce the length of the compressors themselves, see picture 2-C.

	<p>Warning! The oil contained in the sump is at the discharge pressure (high pressure).</p>
--	---

The oil is circulated by exploiting the pressure difference between the crankcase, at the discharge pressure, and the point of injection, where the pressure is slightly higher than the suction pressure (no oil pump is then necessary).

From the crankcase the oil flows through a filter to the suction bearings, to the injection point on the screw profile and to the discharge bearing chamber. For the SRC-S compressors only, there is also a capillary tube that carries the oil to the slide valve control cylinder for capacity control.

Then the oil leaving the slide valve control cylinder -whenever present-, the suction bearings and the discharge bearing chamber flows to the suction side of the rotors and it is compressed through the rotors together with the suction gas.

The high-pressure oil-gas mixture undergoes to a separation process in the ‘DEMISTER’, part (7) in picture 2-A or part (11) in picture 2-B (see paragraph 2-4 ‘Oil separation’); then the oil is collected at the bottom of the oil separator while the gas leaves the compressor through the discharge shut-off valve located on top of the oil separator.

Downstream the oil filter are two connections (oil outlet/inlet) for the connection to an external cooling system, which could be required by the operating conditions (see chapter SA-11 “Additional cooling”).

2.2 Oil flow-rate

As the circulation of oil is generated by a pressure difference, the oil flow rate depends upon the difference between the discharge and suction pressure, according to the following equation:

$$V_{OLIO} = K \cdot \sqrt{P_S - P_A}$$

Where:

V_{oli} = volumetric oil flow-rate through the filter	[l/min]
K = coefficient, depending on the model of compressor	(see Table A)
P_S = discharge pressure	[bar]
P_A = suction pressure	[bar]

SRC-S	113	133	163	183	213	253	255	285	303	305	353	413	463	503	553	603	755	785	885	985
SRC-XS	40	50	60																	
K	5,5			6	6,75						7,5									

Table A: coefficients K for calculating the oil flow-rate;

The minimum oil flow rate required to fulfil all the purposes (lubrication, seal, slide valve control and cooling) is ensured when the compressor works within the established field of operation, as long as the oil filter is normally clean and the oil maintains its characteristics.

During the starting phase, as the pressures are always balanced in the compressor, there is no oil circulation; however the bearings and rotors are designed to tolerate a few seconds of dry operation before the necessary pressure difference is reached.

	<p>Warning! Within 20 seconds from starting, the compressor has to work within the recommended application range (minimum pressure difference, see paragraph 2.8).</p>
--	--

In part-load operation and, in general, when the minimum pressure difference is not easily reached, special measures may need to be adopted, such as:

- ✓ delayed start of the condenser fans, on air-cooled units;
- ✓ the use of a water flow-rate control valve on water-cooled units;
- ✓ the use of a pressure regulating valve between the compressor and the condenser (contact RefComp for further information). At the same time it might be also necessary to keep the time of the compressor part-load operation to the minimum (about 5 seconds).

2.3 Lubricants

The lubricants have been selected mainly based on the following requirements:

- ✓ Seal against leaks along the rotor profile;
- ✓ Correct lubrication of the bearings;
- ✓ Good viscosity characteristics at high temperature;
- ✓ Good miscibility with the refrigerant fluid at low temperature.

	<p>Warning! Do not use lubricants other than those recommended. All the oils approved by RefComp are highly hygroscopic and must not come into contact with the humidity in the air.</p>
--	---

Depending on the kind of refrigerant fluid, below are the oils recommended by RefComp for the SRC-S and SRC-XS series compressors.

2.3.1 Lubricant for HCFC: R22

Supplier	Type	Chemical composition	Density at 15°C [g/ml]	Cinematic viscosity at 40°C [cSt]	Flash point [°C]	Pour point [°C]	Flock point [°C]
CPI	CP-4214-320	complex ester	1.05	298	271	-35	none

Table B: properties of oil for refrigerant R22;

2.3.2 Lubricant for HFC: R407C, R134a, R404A and R507

Supplier	Type	Chemical composition	Density at 15°C [g/ml]	Cinematic viscosity at 40°C [cSt]	Flash point [°C]	Pour point [°C]	Flock point [°C]
FUCHS	Reniso Triton SE 170 ⁽¹⁾	POE	0.98	170	260	-24	none
CPI	Solest 170 (BS 170) ⁽²⁾	POE	0.95	175.2	265	-30	none
UNIQEMA	Icematic SW220 ⁽³⁾	POE	0.98	220	280	-22	none
ICI	Emkarate RL 68 H ⁽⁴⁾	POE	0.98	68	170	-20	none

⁽¹⁾ Standard for SRC-S compressors; RefComp approved alternative lubricant for SRC-XS compressors.

⁽²⁾ Standard for SRC-XS compressors; RefComp approved alternative lubricant for SRC-S compressors.

⁽³⁾ RefComp approved alternative lubricant for SRC-S and SRC-XS compressors with R134a.

⁽⁴⁾ RefComp approved alternative lubricant for SRC-XS compressors with R134a.

Table C: properties of lubricant oil for refrigerants: R407C, R134a, R404A and R507;

2.4 Oil separation

The separation of the oil is required for the following reasons:

- ✓ to ensure the accumulation of oil in the compressor crankcase so that it can continuously be delivered to the bearings and the rotors;
- ✓ to prevent the migration of oil from the compressor into the refrigerant circuit.

RefComp has developed a high efficiency oil separator with low space requirements.

The presence of the oil separator could affect the compressor sound emissions, however this is already particularly low because of the thickness and shape of RefComp compressor design.

The oil is separated thanks to:

- ✓ the impact with the inside surface of the oil separator;
- ✓ the difference in specific mass between the oil and the gas;
- ✓ actual filtering of the discharged gas by the “DEMISTER” (part (7) and (11) respectively in picture 2-A and 2-B; variation in direction and speed of the compressed refrigerant-oil mixture).

Picture 2.C points out the specific position of the oil separator both for the SRC-S series and the SRC-XS one. While picture 2-D shows the schematic cross-section of a SRC-S compressor, highlighting the separation process through the oil separator.

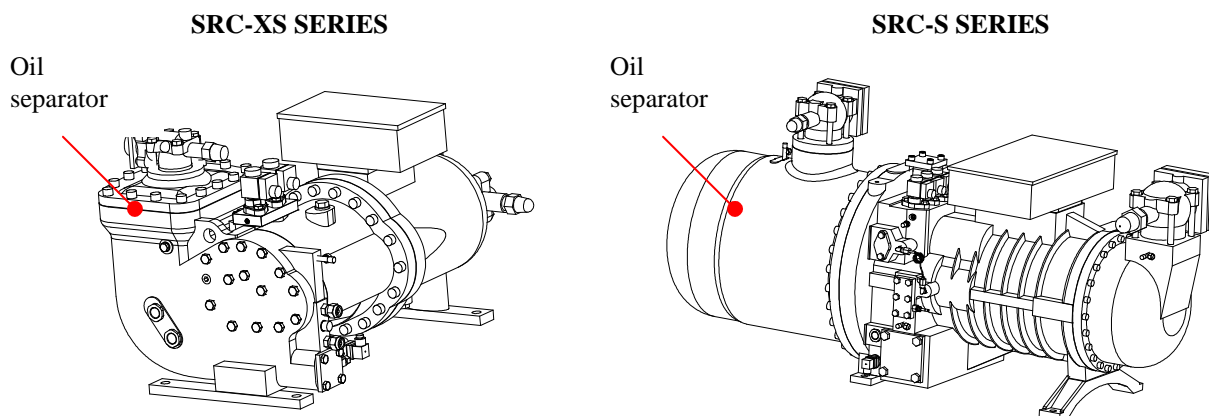

Picture 2-C: specific position of the oil separator both for the SRC-S series and the SRC-XS one;

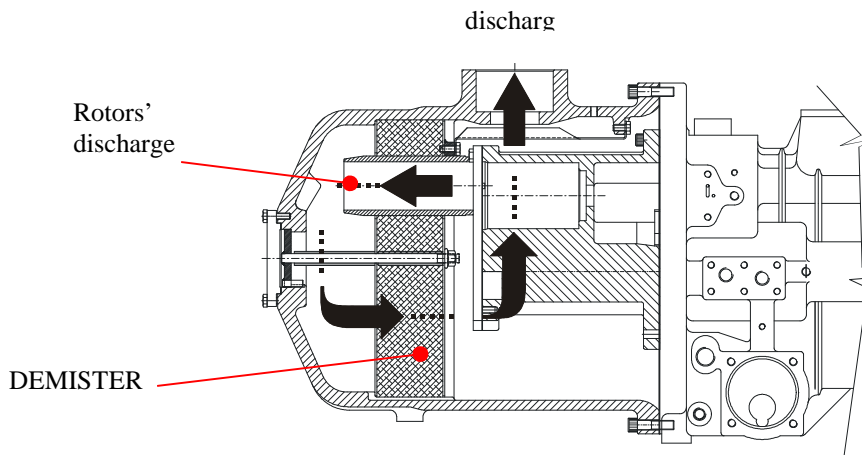

Picture 2-D: separation process of the oil-refrigerant mixture using the ‘DEMISTER’ separator in the SRC-S series compressors;

The high pressure oil-gas mixture leaving the rotors is subjected to an initial separation due to the different velocity between the gas and oil droplets; further separation comes from the impact of the mixture against the inside wall of the sump, where the oil droplets are collected and slide to the bottom; finally the mixture is subjected to the main separation process by flowing through the “DEMISTER” filter, where the oil droplets continuously change their velocity and direction. The oil that is separated from the refrigerant then accumulates at the bottom of the separator.

The lower the refrigerant mass flow rate, the higher the oil separation efficiency. Under the most critical conditions the oil carry-over rate is less than 2% of the refrigerant mass leaving the compressor.

2.5 Oil filter

The compressors are fitted with a high efficiency oil filter. In models SRC-S-113/133/163 this is positioned inside the compressor, and therefore to be inspected the discharge bell and the oil separator need to be removed. In the SRC-XS compressors and in the remaining models of the SRC-S series, on the other hand, the oil filter is positioned on the bottom of the crankcase, as shown in picture 2-E¹, and as a result it is easily accessible from the outside of the compressor. For further details on the position, see chapter SA-08: “Dimensional drawings and packaging”.

The oil filter must always be clean to ensure correct lubrication. The cleanness condition of the filter can be checked by the pressure drop through the filter itself. Under normal conditions and with a new filter the pressure drop is lower than 0.8 bar.

When first starting the compressor, the oil filter may become clogged quite quickly if the refrigerant circuit has not been carefully cleaned.

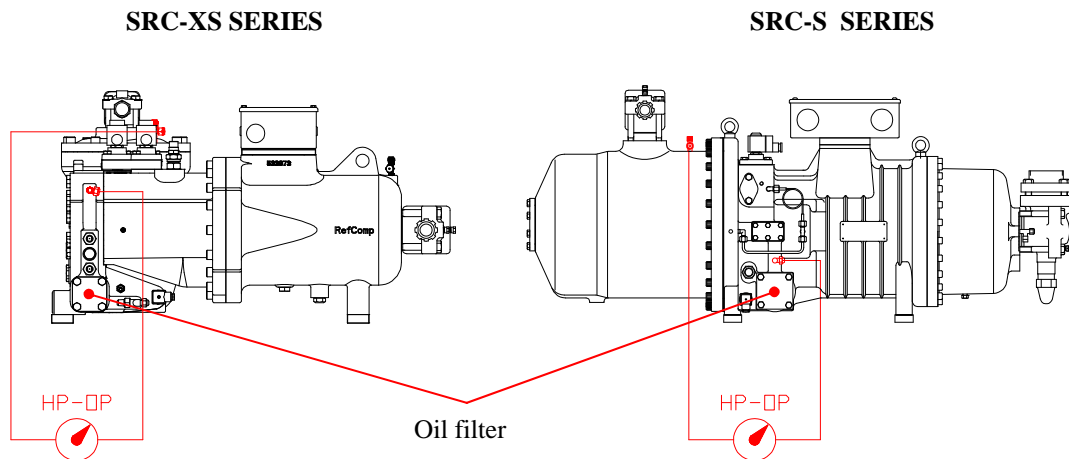

Picture 2-E: position of the oil filter in the SRC-XS and SRC-S series compressors (in models 113/133/163 the filter is located inside the oil separator) and definition of the HP-OP pressure drop across the filter;

Considering HP as the high pressure -discharge side- and OP the pressure of the oil leaving the filter, the pressure difference **HP-OP** represents the pressure drop across the filter.

	<p>Warning!</p> <p>For the limit value of the pressure drop HP-OP across the oil filter at which the filter needs to be replaced, see paragraph 2.8: “lubrication monitoring”.</p>
--	---

When the pressure drop across the filter exceeds the values indicated in paragraph 2.8, the filter is dirty and must be replaced. The compressors are fitted with a fine mesh oil filter: in some cases, then, the filter may even need to be replaced after just a few hours of operation, and in any case when the pressure drop exceeds the values shown in the above-mentioned paragraph (consequently, a spare filter should be ordered together with the compressor).

¹ This is simply a schematic drawing; refer to the dimensional drawing for each individual compressor to identify the actual position of the high and low pressure fittings and the oil filter.

2.6 Oil heater

The oil heater is designed to prevent the excessive dilution of refrigerant in the oil when in standstill, and must be on when the compressor is off. The heater is a tubular heating element, see picture 2-H. In The SRC-XS compressors and in the models SRC-S from 183 to 985, it is inserted in a socket made near the oil filter, see picture 2-F, while in the other three compressors SRC-S-113/133/163 it is located in a socket made in the front of the oil sump, see picture 2-G. For further details on the position, see chapter SA-08: “Dimensional drawings and packaging”.

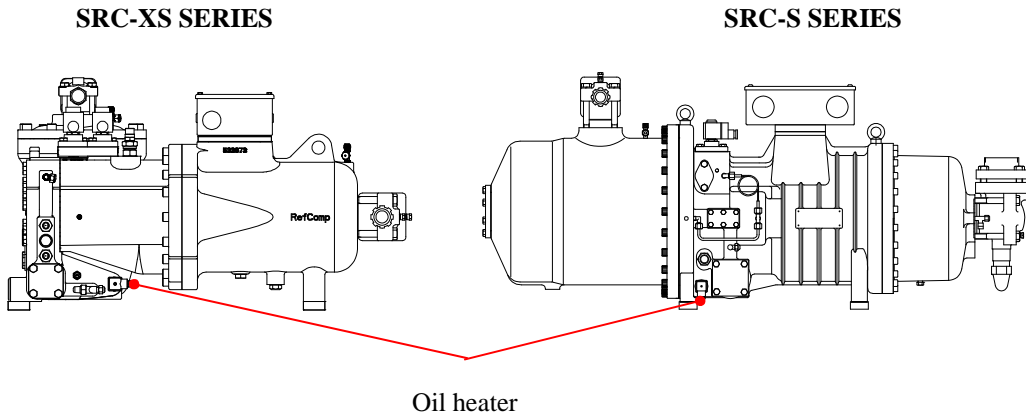

Picture 2-F: position of the oil heater: SRC-XS series and SRC-S series from the model 183 to the 985;

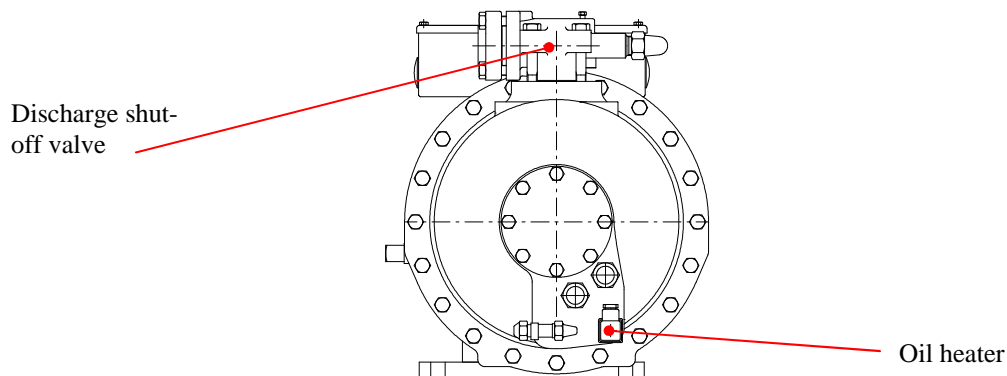

Picture 2-G: position of the oil heater: models SRC-S-113/133/163;

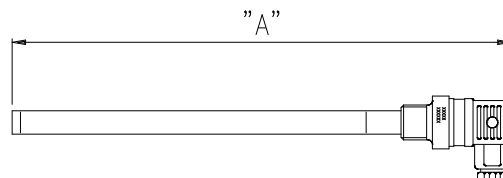

Picture 2-H: Oil heater;

The characteristics of the crankcase heater are reported on table D.

SRC-S	113	133	163	183	213	253	303	255	285	305	353	413	463	503	553	603	755	785	885	985
SRC-XS	40	50	60																	
A	248							302												
Potenza nominale [W]	200									275										
Alimentazione [V-Hz]	220-50/60																			
Coppia di serraggio [Nm]	30																			

Table D: characteristics of the crankcase heater;

The oil heater must be used when the compressor is off, and in the following situations:

- ✓ when the compressor is installed outdoors (if necessary, the oil separator should be insulated);
- ✓ extended standstill periods;
- ✓ high refrigerant charge;
- ✓ risk of the refrigerant condensing inside the compressor. During standstill the compressor crankcase must have the highest temperature in the entire refrigerant circuit.

	<p>Warning!</p> <p>Before starting up for the working season, the heater must be on for at least 24 hours before starting the compressor.</p>
---	--

2.7 Oil level

If the compressor is delivered with suction and discharge shut-off valves already fitted, the oil had been charged by the manufacturer. Otherwise the oil is supplied in separate cans inside the packaging, to prevent contact with the air when the compressor is installed. The standard oil charge is indicated in the table of technical data reported in chapter SA-06: “*Designation of the model and technical specifications*”.

In models SRC-XS-40/50/60 and SRC-S-113/133/163/255/285/305/755/785/885/985 the oil level can be checked through two sight glasses (for the position on the compressor, see picture 2-I on the next page): the top sight glass indicates the optimum level for the correct operation of the compressor, while the lower one indicates the minimum level, below the which the compressor cannot operate.

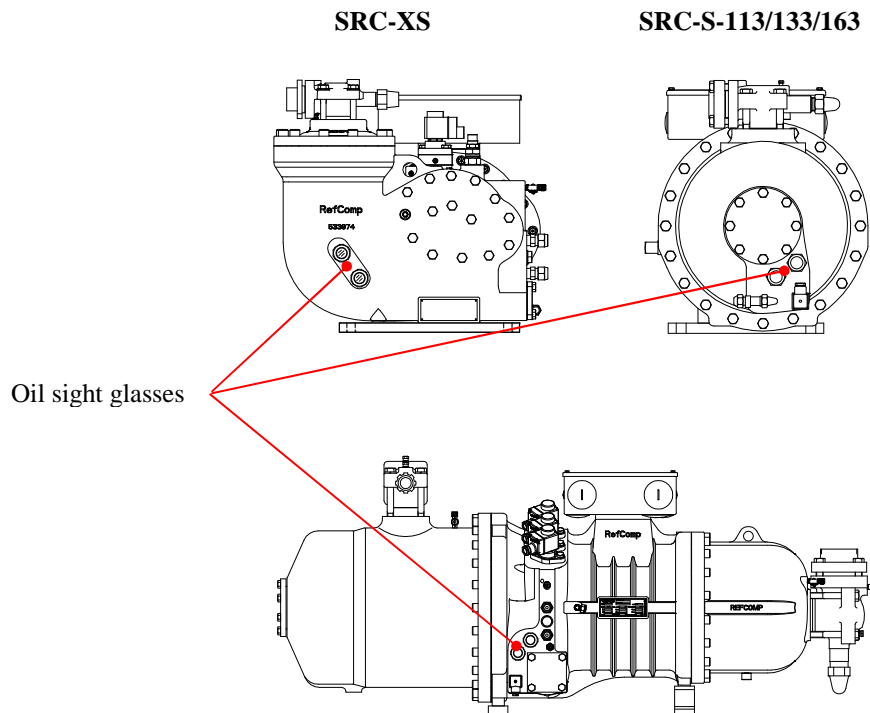

Picture 2-I: position of the two oil sight glasses in all the models of SRC-XS series and in models SRC-S 113/133/163/255/285/305/755/785/885/985;

In all the other SRC-S series compressors, the oil level is monitored using a single sight glass, as indicated in picture 2-L.

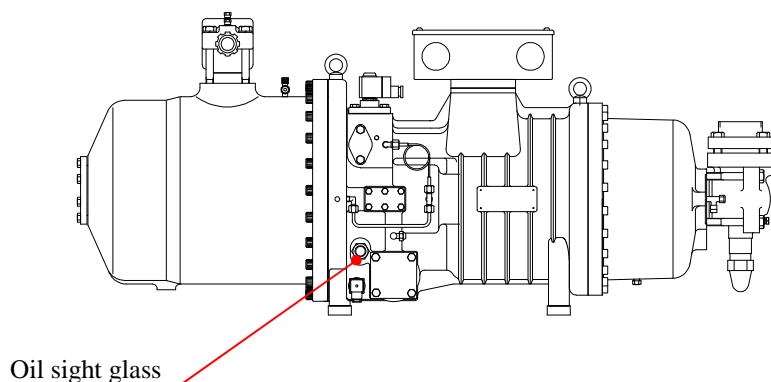

Picture 2-L: position of the oil sight glass in models SRC-S-183/213/253/303/353/413/463/503/553/603;

During operation a certain quantity of oil may migrate into the refrigerant circuit. Moreover for the SRC-S compressors a variation in the load entails also a variation in the amount of oil contained in the hydraulic cylinder which control the slide valve; consequently there may be fluctuations in the oil level due to its flowing from and to the slide valve control cylinder. In any case, during operation the level of oil must remain visible within the sight glass.

These sight glasses also show if there is too much refrigerant diluted in the oil. In fact, this problem is highlighted by the continuous presence of foam and is caused by an excessive cooling of the oil when the additional cooling is obtained by the liquid injection (see chapter SA-11: “*Additional cooling*”).

	<p>Warning!</p> <ul style="list-style-type: none"> ✓ According to the type of installation and the operating conditions of the compressor (whether the oil cooling circuit is used or not, see chapter SA-11: ‘<i>Additional cooling</i>’), some extra oil may be needed. ✓ The oil level in the sight glass should be checked when the compressor is on.
---	--

2.8 Lubrication monitoring

Oil temperature monitoring

Normally the lubrication can be indirectly monitored by checking the discharge temperature of the oil: lack of lubrication leads to an increase of that value.

Hence a temperature sensor is available (optional with the INT 69 VS module, standard with INT 69 RCY module), to monitor the oil temperature (see chapter SA-05: ‘*Electrical devices*’).

Whenever this accessory is not used, a safety thermostat should be installed on the discharge pipe to switch off the compressor as the temperature reaches 120°C.

	<p>Warning!</p> <p>The additional cooling of the oil (chapter SA-11) does not guarantee the indirect monitoring of the lubrication through the oil temperature value.</p>
---	--

Depending on the operating conditions, however, the discharge temperature may be quite different from the alarm condition of the above-mentioned device (120°C). This occurs especially when using the R134a refrigerant.

Consequently, the delay in the increase and in reaching the critical temperature of 120°C, corresponding to insufficient lubrication, must be considered, as the correct operation of the compressor may be affected in this period. As a result, RefComp suggests further alternative methods for monitoring correct lubrication. They are described below.

a. Static pressure control.

The correct circulation of the oil is guaranteed by the fact that both the filter is clean and the compressor operates in the admissible field of operation (see chapter SA-10: “*Application range*”; picture 2-N shows an example).

With reference to picture 2-M¹ and 2-N, to protect the compressor against insufficient lubrication, the following three pressure values need to be measured:

- ✓ The high pressure “HP”;
- ✓ The oil pressure “OP”;
- ✓ The low pressure “LP”;

and make sure that:

- ✓ The compressor works inside the application range, within 20 sec. from the starting;
- ✓ $HP - OP < 3,5 \text{ bar}$, if the compressor works outside the area A3.
- ✓ $HP - OP < 1,5 \text{ bar}$, if the compressor works inside area A3.

¹ This is simply a schematic drawing; refer to the dimensional drawing for each individual compressor to identify the actual position of the pressure connections.

So the level of filter lodgement is not fixed but rather depends on the operating conditions of the compressor; that is, if working inside area A3, the filter will be considered dirty when the pressure drop across the filter is greater than 1.5 bar. Outside of area A3, on the other hand, but always within the application range, the filter will be considered dirty if the pressure drop exceeds the value of 3.5 bar.

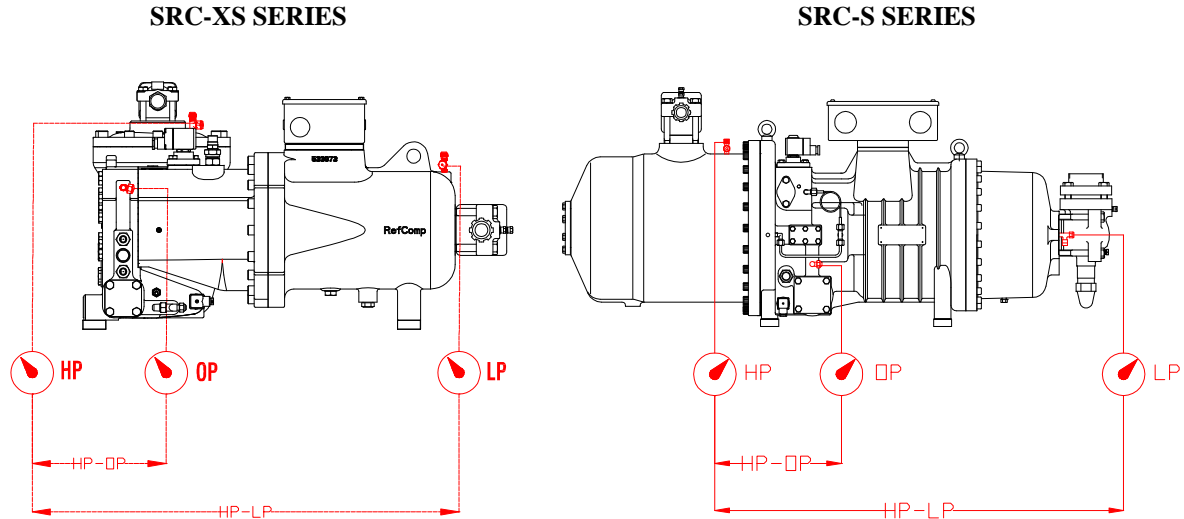

Picture 2-M: measuring the HP, OP and LP pressure values in the SRC-XS and SRC-S series compressors;

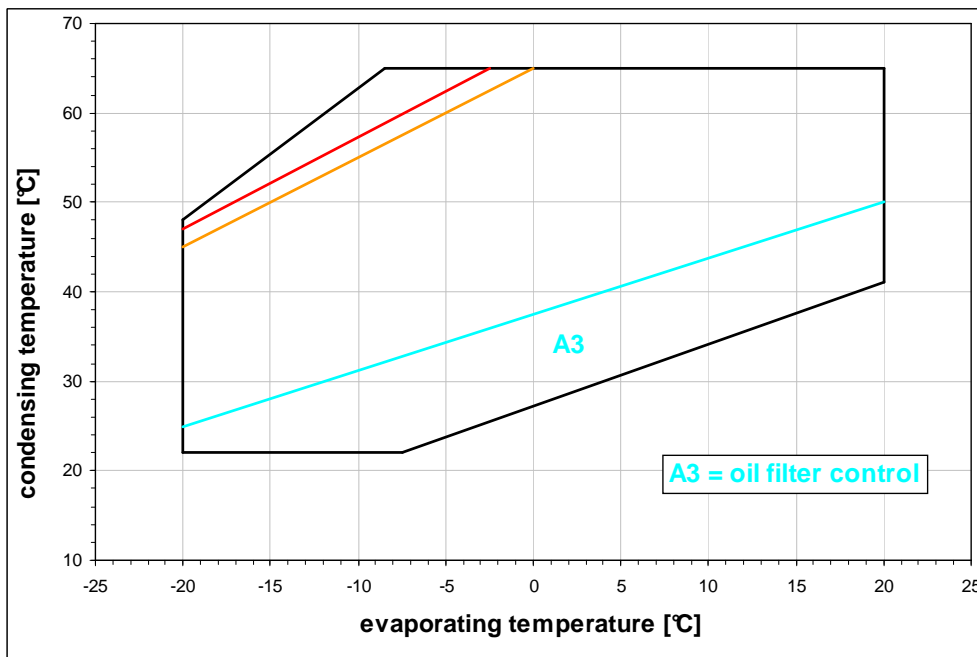

Picture 2-N: generic application limit for series SRC-XS and SRC-S compressors;

	<p>Warning!</p> <ul style="list-style-type: none"> ✓ The compressor cannot operate for more than 20 seconds outside of the conditions required by the application limits and with the oil filter dirty. After such time, the protection system have to be activated to stop the compressor; ✓ The differential pressure switch for monitoring the status of the oil filter must be suitable for high pressure.
--	---

b. Flow control.

The monitoring of oil flow through the compressor could be done with a flow switch kit (see chapter EA-04: *“Components”*)

This device is a dynamic type control cause, setting aside how much oil is in the crankcase, shows its effective flow inside the circuit made on the body of compressor. This circulation is granted only by the difference of pressure between discharge and suction line and is hindered by concentrated pressure drops as for instance the oil filter.

The oil flow switch with its inlet and outlet connections are assembled from the outside to the body of compressor by customer, according to his dimensional needs.

The electrical contact of oil flow switch is “open type” but the correct working condition is that, during the running of compressor, the oil flowing through it will close the electrical contact.

If will happen that the difference between discharge and suction pressure couldn't assure the flow of oil it is beared a delay of intervention of oil flow switch.

The statements recommended by RefComp for this delay are:

- 120 seconds during start-up procedure;
- 60 seconds during normal working.

SRC-XS and SRC-S series compressors
Capacity control
(SA-03-04-E)

3. CAPACITY CONTROL	2
3.1 SRC-S SERIES	2
3.1.1 <i>Operating principle and oil control circuit</i>	2
3.1.2 <i>Step capacity control</i>	3
3.1.3 <i>Control sequence: step configuration</i>	9
3.1.4 <i>Infinity capacity control: stepless</i>	10
3.1.5 <i>Control sequence: stepless configuration</i>	<i>Errore. Il segnalibro non è definito.</i>
3.2 SRC-XS SERIES	14
3.2.1 <i>L1 configuration: working principle and control circuit</i>	14
3.2.2 <i>L2 configuration: working principle and control circuit</i>	16
3.2.3 <i>Control sequence: step configuration</i>	19
3.3 PROCEDURE FOR STARTING AND STOPPING THE COMPRESSOR	20
3.4 OPERATING LIMITS AT PART LOAD	21

3. Capacity control

The RefComp screw compressors can operate both at full load and part load. In particular for the SRC-XS compressors only the configuration 'step' L2 with 3 capacity steps (50-75-100% load) is available; while for the SRC-S compressors the user can choose among the 'step' L4 configuration with 4 capacity steps (minimum-50-75 and 100% load) and the 'stepless' LZ configuration (continuous variation of the load, either from the minimum step to 100%, or from 50 to 100%).

Hereinafter the two compressor series SRC-S and SRC-XS will be considered separately. In addition, the differences which characterized the new models SRC-S-255/285/305/755/785/885/985 with respect to the other models of the same series, will be highlighted as well.

3.1 SRC-S series

3.1.1 Operating principle and oil control circuit

For the models SRC-S-113/133/163/183/213/253/303/353/413/463/503/553/603 the cylindrical chambers that house the screw rotors are fitted with a upper longitudinal port, whose connection with the suction side is regulated by the position of the slide valve (17), see picture 3-A. For the models SRC-S 255/285/305/755/785/885/985 that port and slide valve (1) are located underneath the rotors instead, see picture 3-B.

When the slide valve completely closes the above mentioned port, the effective compression length is maximum and coincides with the entire length of the rotors; when, on the other hand, the valve moves towards the discharge and the opening expands longitudinally, the effective working length of the rotors is reduced and as a consequence a smaller quantity of gas is processed. As a result, adjusting the volume taken in by the rotors make it possible to control the mass flow processed and definitely the cooling capacity generated by the compressor.

The slide valve is controlled by a hydraulic cylinder activated by the oil pressure. Concerning the models SRC-S-113/133/163/183/213/253/303/353/413/463/503/553/603, the oil control circuit for the capacity control is characterized by three normally-closed solenoid valves: 14, 15 and 16 in the step configuration and 14, 15 e 19 in the stepless configuration, see pictures 3-A and 3-N.

On the other hand, concerning the models SRC-S-255/285/305/755/785/885/985, in both the configuration the oil circuit is characterized by the three normally-closed solenoid valves above mentioned (14 – 15 – 16) and by two different plates (4), which allow to install the step and stepless configurations, see pictures 3-B and 3-O. This means that the oil circuit can be modify just by switching the two plates (4).

The following paragraphs describe the operating principle of the oil circuit in the step and stepless configurations and, as you can see, this principle is the same in both the SRC-S series compressor types.

The main feature which characterizes the new models 255/285/305/755/785/885/985 is the possibility to make the switch between step and stepless configuration only changing the plate (4) as reported in chapter SA-15 *Capacity control conversion*.

3.1.2 Step capacity control

The slide valve is controlled by a hydraulic piston that can have four distinct positions, corresponding to the capacity steps: 100 - 75 - 50% - minimum step (note: the effective capacity steps may differ from the rated values, according to the normal operating conditions and from compressor to compressor).

The following pictures 3-A and 3-B show the internal oil circuit for the capacity control in the new models 255/285/305/755/785/885/985 and in the other of the SRC-S series respectively. As you can see from these pictures, for all the compressors the oil circuit is characterized by the three normally-closed solenoid valves 14, 15 and 16 which respectively allow to control the three capacity steps: minimum capacity, 50 and 75%.

Below is a brief description of the operation of the oil circuit in the four compressor capacity steps.

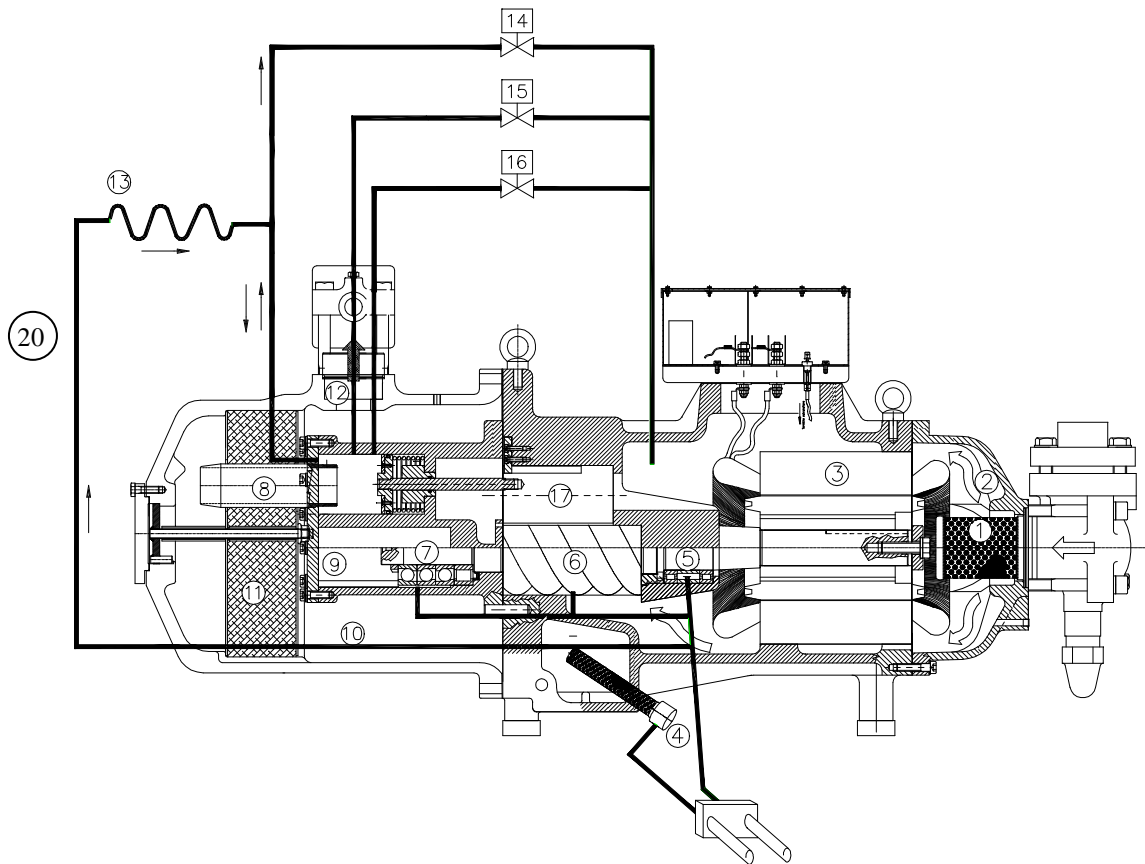

Picture 3-A: step capacity control oil circuit for the models: SRC-S-113/133/163/183/213/253/303/353/413/463/503/553/603;
14, 15, 16: capacity control solenoid valves;
17: capacity control slide valve and operation piston;
13: capillary tube (external to the compressor);

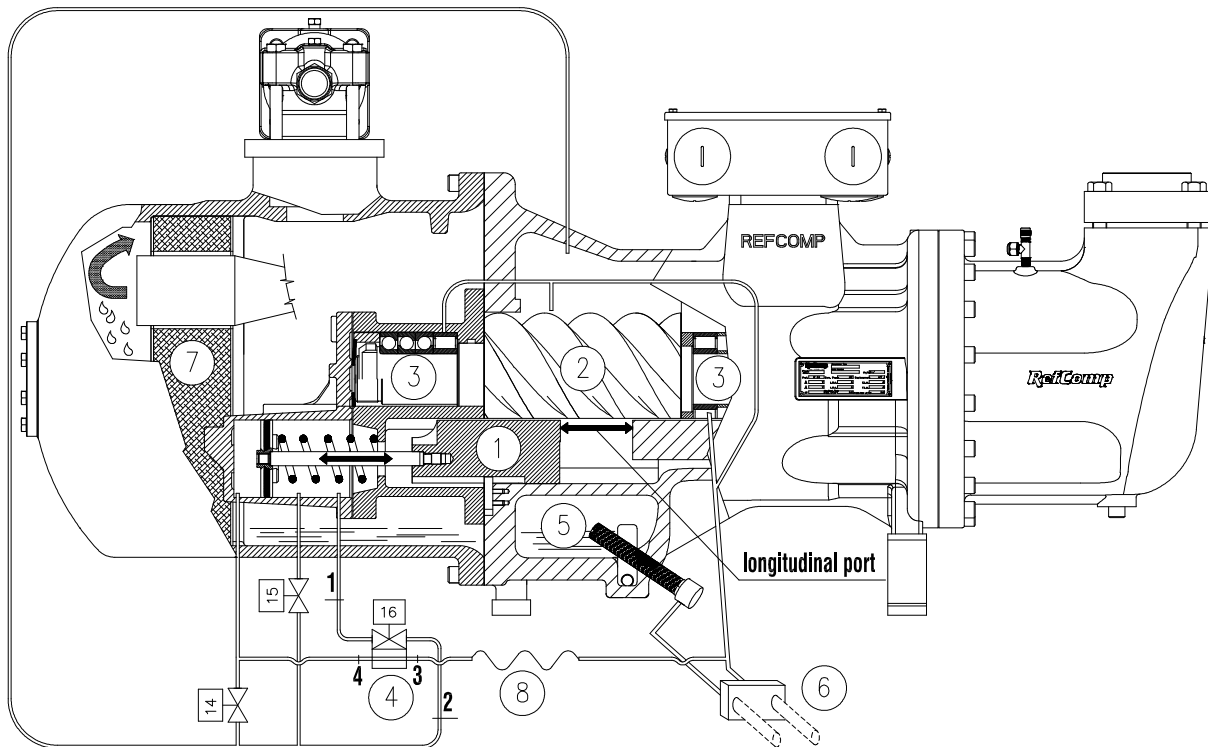

Picture 3-B: step capacity control oil circuit for the models: SRC-S-255/285/305/755/785/885/985;
14, 15, 16: capacity control solenoid valves;
1: capacity control slide valve and operation piston;
4: step-stepless switch plate;
8: capillary tube (internal to the compressor);

✓ **MINIMUM CAPACITY STEP (COMPRESSOR STEP FOR START UP AND STOP)**

Pictures 3-C and 3-D show how the oil runs inside the control circuit. At the minimum step the solenoid valve 14 is opened, while the valves 15 and 16 are closed. Therefore the oil, coming from the oil reservoir, flows through the opened port to the suction side, not pressurising the control cylinder. Consequently the piston is pushed to the end stroke, the longitudinal port is completely opened on the suction side and the length along which the rotors are working is the shortest.



Warning!

Concerning the step capacity control mode (4 steps), the minimum capacity step can be used only to start and stop the compressor; it cannot be used to give cooling power.

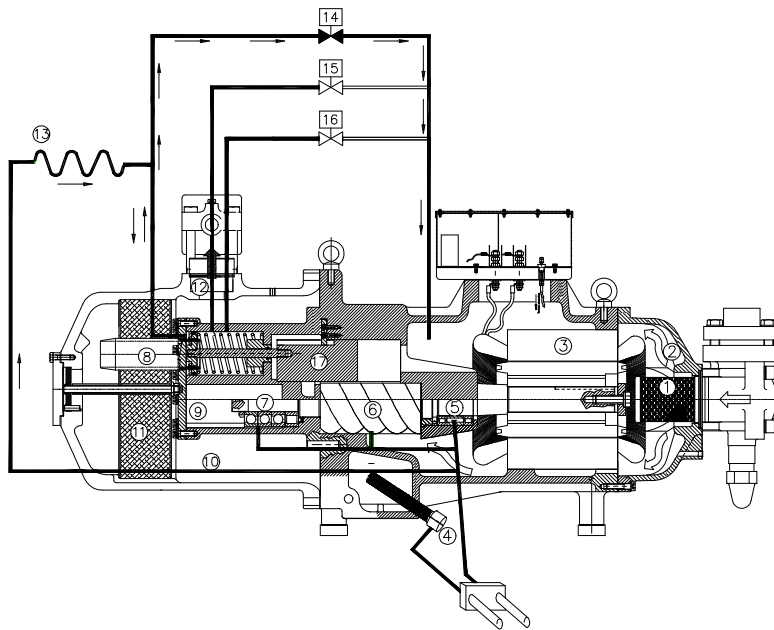

Picture 3-C: capacity control at minimum step: models 113/133/163/183/213/253/303/353/413/463/503/553/603;

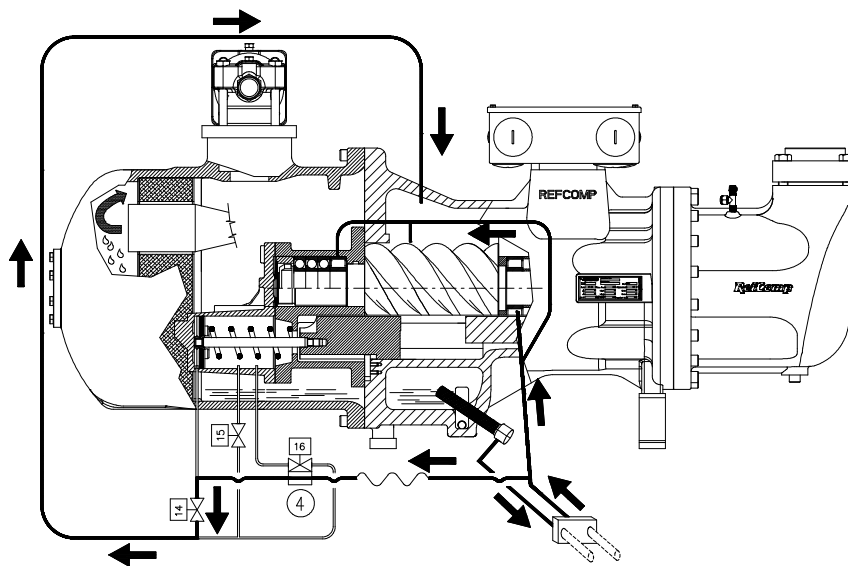

Picture 3-D: capacity control at minimum step: models 255/285/305/755/785/885/985;

✓ **50% CAPACITY**

With reference to pictures 3-E and 3-F at 50% capacity, the solenoid valve 15 is open while the valves 16 and 14 are closed; the oil enters the cylinder (through the 1st hole on the left) and drives the piston to the position corresponding to the 2nd hole, where the oil flows to the suction side. The slide valve also moves and partially closes the longitudinal opening, thus increasing the effective working length of the rotors.

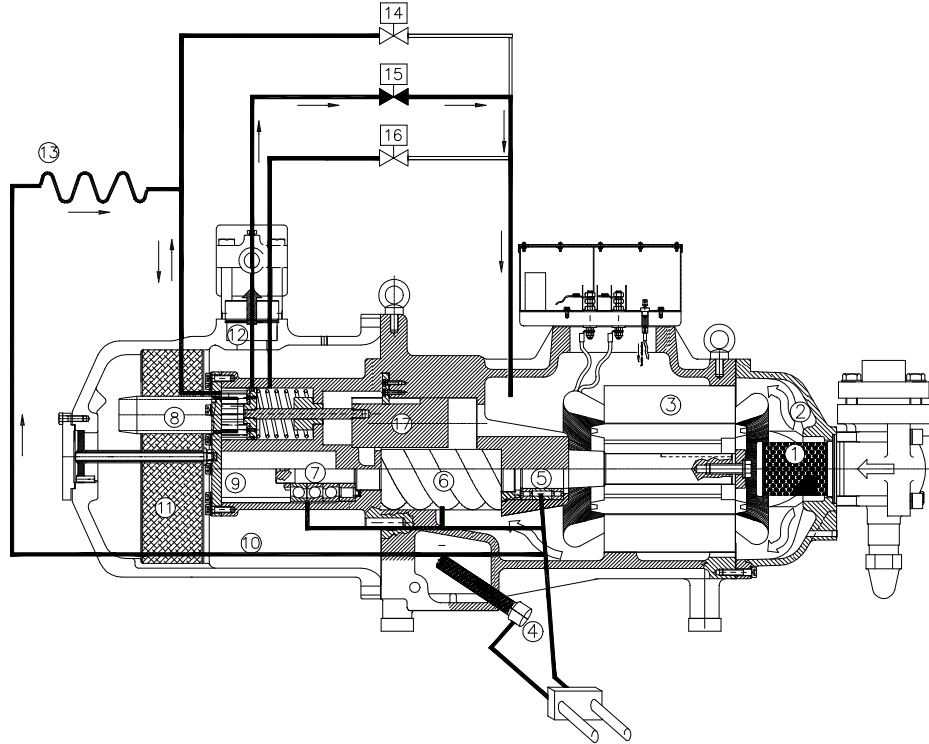

Picture 3-E: capacity control at 50% step: models 113/133/163/183/213/253/303/353/413/463/503/553/603;

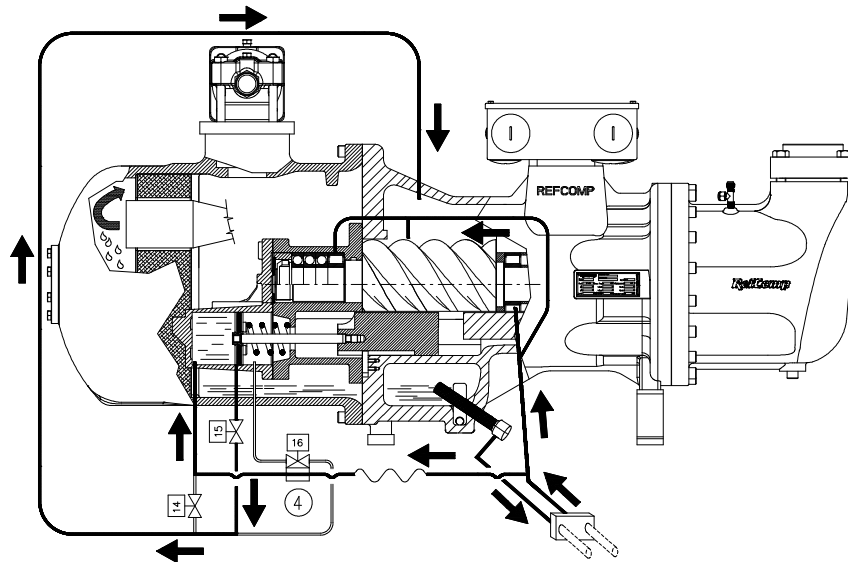

Picture 3-F: capacity control at 50% step: models 255/285/305/755/785/885/985;

✓ **75% CAPACITY**

At 75 % capacity, see pictures 3-G and 3-H, the situation is similar to the previous one, but now the solenoid valve 16 is open while the valves 15 and 14 are closed; the control piston is thus positioned corresponding to the 3rd hole, the slide valve closes the opening further and increases the working length of the rotors.

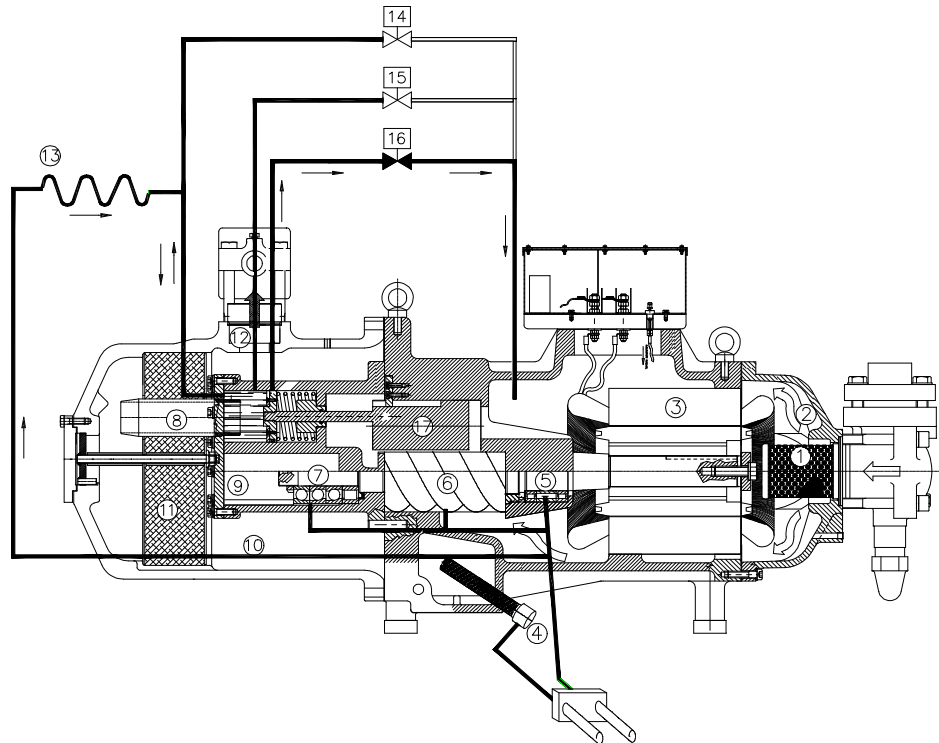

Picture 3-G: capacity control at 75% step: models 113/133/163/183/213/253/303/353/413/463/503/553/603;

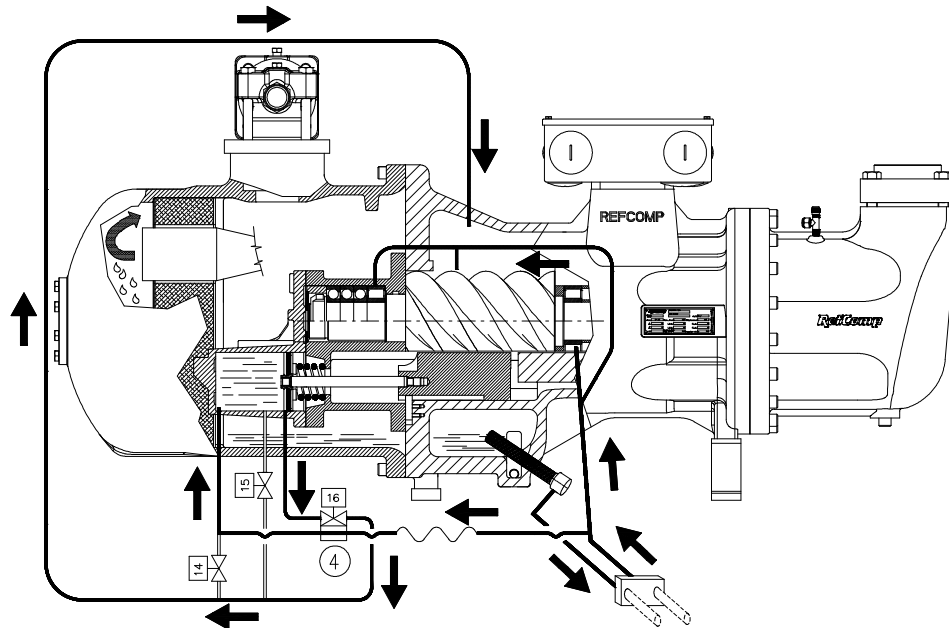

Picture 3-H: capacity control at 75% step: models 255/285/305/755/785/885/985;

✓ **100% CAPACITY**

At 100% capacity, see pictures 3-I and 3-L, all the solenoid valves are closed; the oil can no longer leave the cylinder and pushes the piston to the limit on the right side and the slide valve completely closes the longitudinal opening, meaning that the compression occurs along the entire length of the rotors.

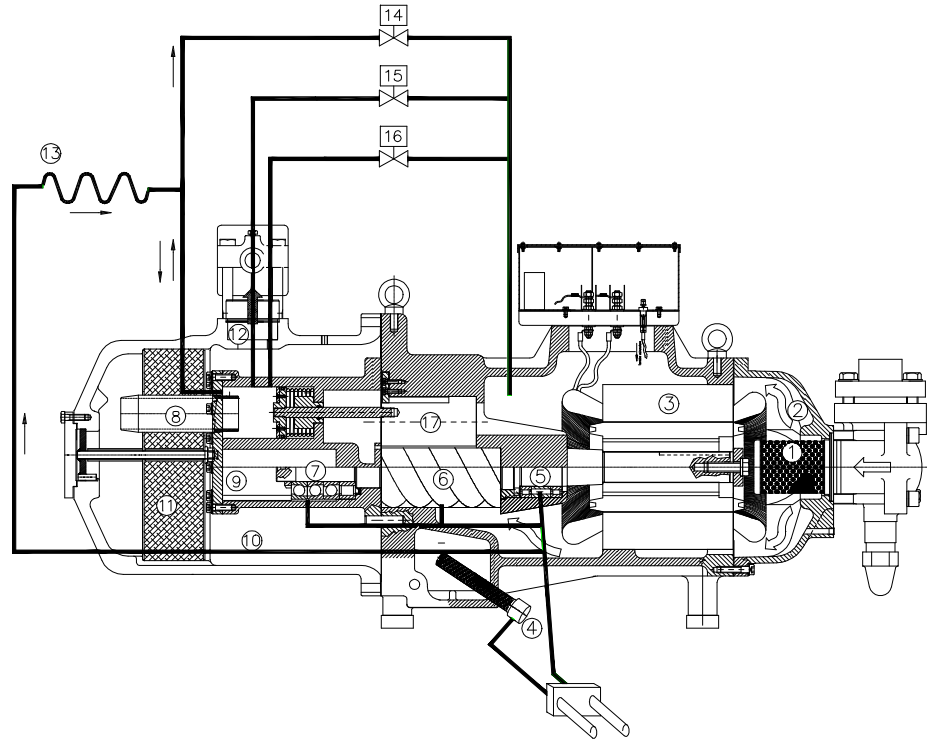

Picture 3-I: capacity control at 100% step: models 113/133/163/183/213/253/303/353/413/463/503/553/603;

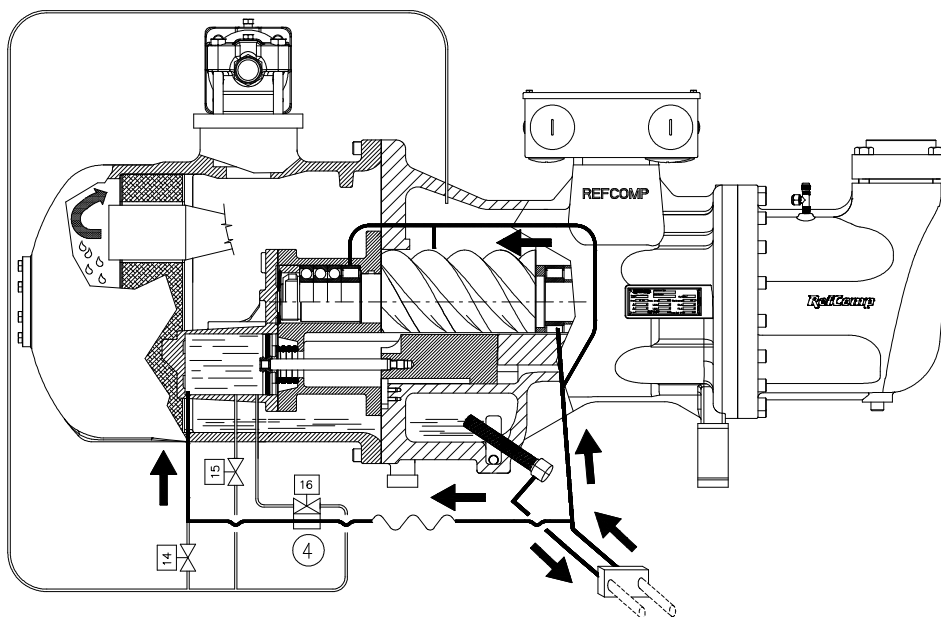

Picture 3-L: capacity control at 100% step: models 255/285/305/755/785/885/985;

3.1.3 Control sequence: step configuration

The oil flow is controlled by the three solenoid valves, normally-closed, positioned on top of the compressor casing, see picture 3-M and 3-N. For all the compressors series SRC-S these valves are energized according to the logic shown in Table A.

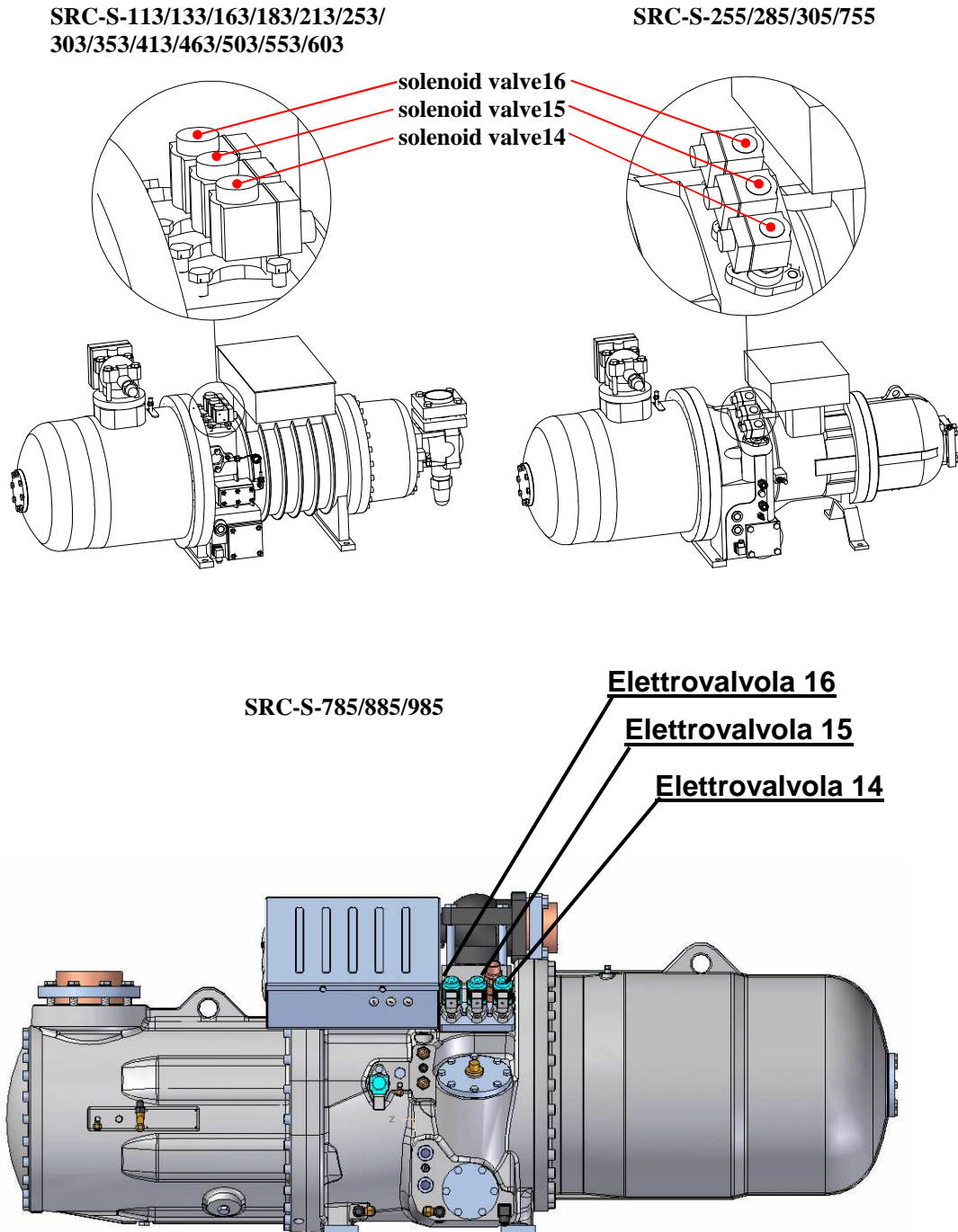

Picture 3-M : solenoid valve position on the compressors ;

Load (capacity steps)	Solenoid valves		
	16	15	14
100%	Off	Off	Off
75%	On	Off	Off
50%	Off	On	Off
Minimum step (start up and stop)	Off	Off	On

“Off”= solenoid not energized; “On”= solenoid energized;

Table A: operating logic of the solenoid valves for step capacity control;

3.1.4 Infinity capacity control: stepless

Infinite capacity control is recommended whenever the cooling capacity of the system has to be controlled with a high degree of precision, while it is not very useful in systems featuring high inertia, where step capacity control is more suitable.

With reference to picture 3-N, to perform the stepless configuration in the models 113/133/163/183/213/253/303/353/413/463/503/553/603 you have to move the solenoid valve located in position (16) to the position (19) on the circuit (20). With this switch the valve, which in the step configuration controlled the 75% capacity step, now controls the oil flow towards the slide valve control cylinder. The other two solenoid valves do not change their position.

In the models 255/285/305/755/785/885/985 with this configuration, see picture 3-O, the plate (4) is configured so that the solenoid valve (16) controls the oil flow entering the hydraulic cylinder that operates the slide valve (section of the circuit marked by numbers 3 and 4 in Figure 3-B). The 75% step control function is disabled, and for this reason the section of circuit marked by numbers 1 and 2 in picture 3-A will not be shown in picture 3-O below.

The cooling capacity is therefore controlled by using the normally-closed solenoid valves (14), (15) e (19) in the models 113/133/163/183/213/253/303/353/413/463/503/553/603 and the valves (14), (15) e (16) in the other three models 255/285/305/755/785/885/985. The valves have the following logic:

- ✓ (16), (19): fill the hydraulic cylinder for increasing the cooling capacity required by the users;
- ✓ (14), (15): empty the hydraulic cylinder, until the minimum step or 50%, to decrease the cooling capacity required by the users.

This brings about continuous control of the flow processed by the compressor, from the minimum value to the maximum value. For details on how to convert the configuration from the step to stepless for all the compressors SRC-S, see chapter SA-15 “Capacity control conversion”.

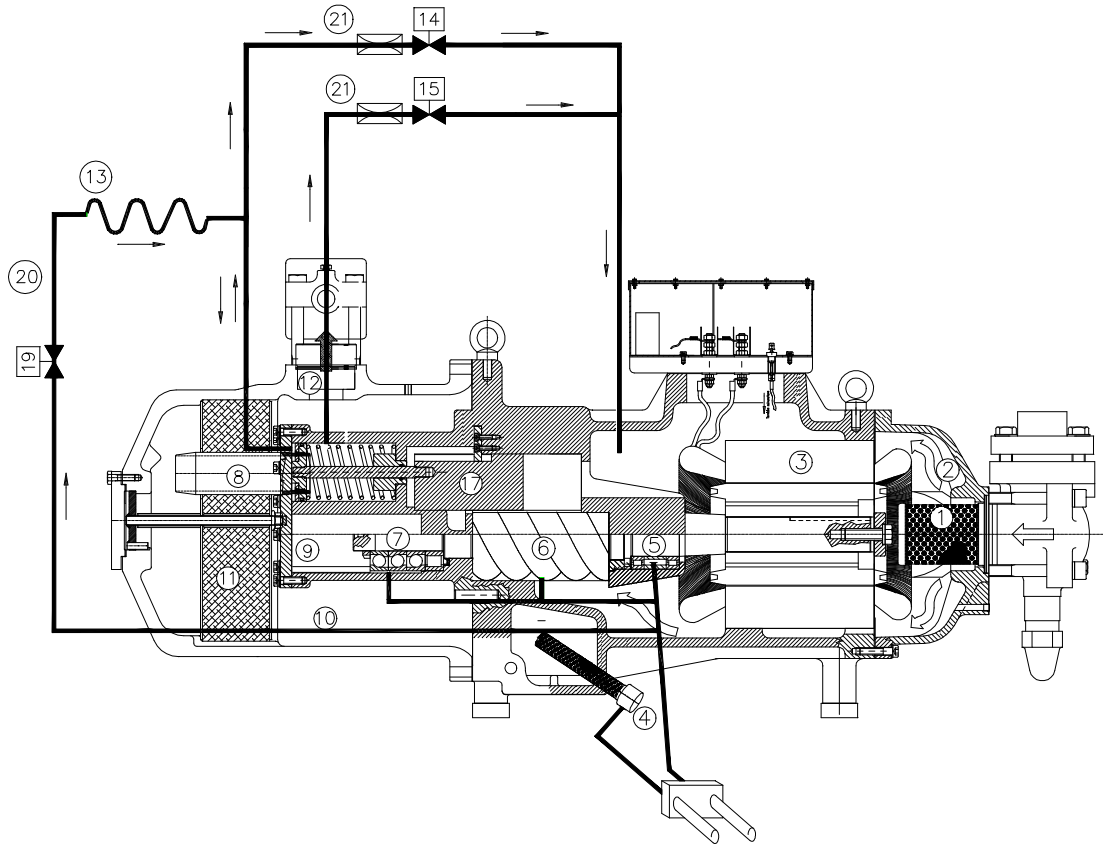

Picture 3-N: infinite capacity control oil circuit (step less configuration): models SRC-S-113/133/163/183/213/253/303/353/413/463/503/553/603;

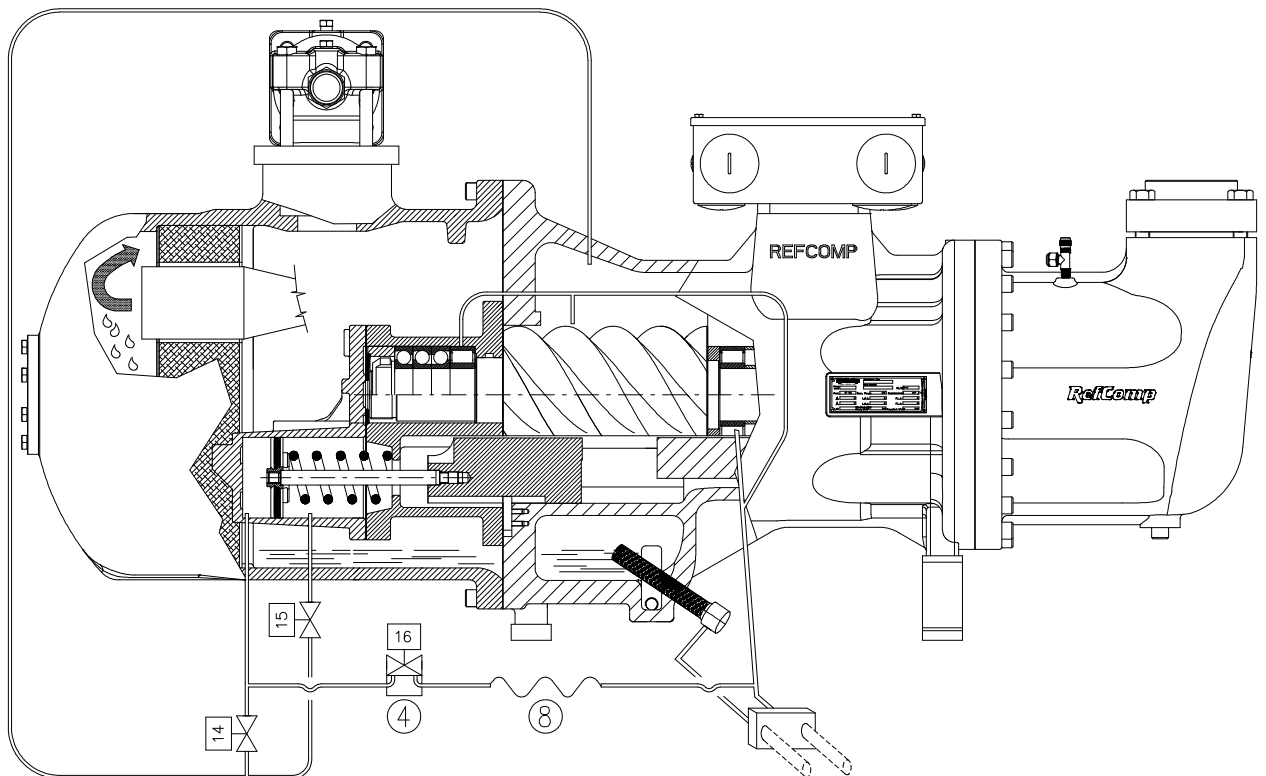

Picture 3-O: infinite capacity control oil circuit (step less configuration): models SRC-S-255/285/305/755/785/885/985;

Only for the models 113/133/163/183/213/253/303/353/413/463/503/553/603 the oil channels must be throttled to achieve slower motion and more accurate positioning of the control piston. With reference to the picture 3-N, the load channel (20) can be throttled by installing a modified capillary tube (13). The unload channel (14) or (15) can be throttled by installing an orifice (21) upstream the solenoid valve.

Both items are supplied on request as they belong to the conversion kit from the configuration step to the stepless one, and have to be assembled by the user (see chapter SA-15: “Capacity Control Conversion”).

3.1.5 Control sequence: stepless configuration

Cooling capacity control is obtained using solenoid valves (14),(15) and (16) which have to be excited according to logic control shown in Picture 3-P and Table 3-B

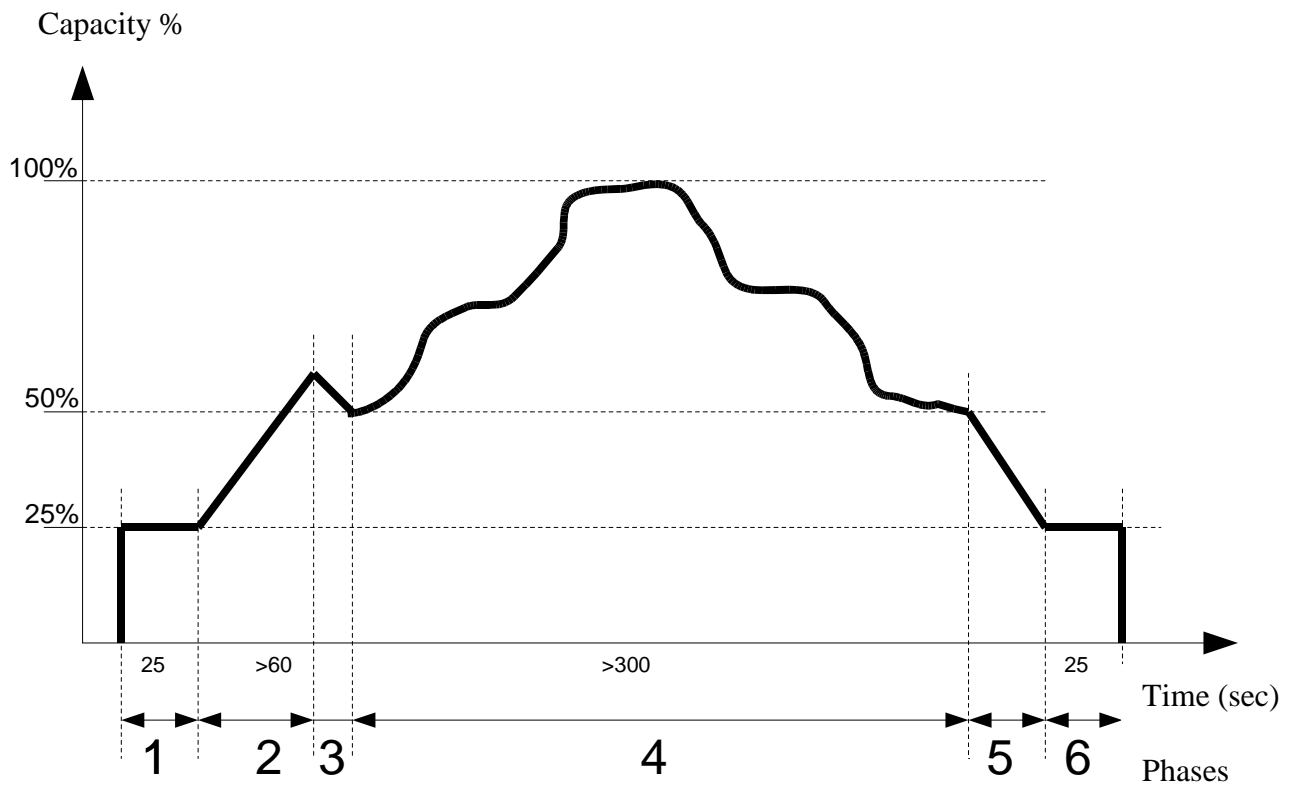



Figure 3-P Logic control of solenoid valves for stepless configuration

STEPLESS CONTROL 100÷50%				
Phase	Regulation	SOLENOID VALVE		
		14	15	16
1	Start-up	ON	OFF	OFF
2	Loading > 50%	OFF	OFF	ON
3	Unloading to 50 %	OFF	ON	OFF
4	Modulation	OFF	ON/OFF	ON/OFF
5	Unloading to 25%	ON	OFF	OFF
6	Stop	ON	OFF	OFF

“Off”= solenoid not excited

“On”= solenoid excited

Tabella 3-B: Control sequence of solenoid valves in stepless configuratio

	<p>Warning !</p> <p>The working at partial load condition is allowed according to the application limits reported in the chapter SA-10: “<i>Application limit</i>”.</p> <p>Particularly, the compressor can work at the minimum capacity step only during the start up phase, the stop phase (see paragraph 3.3) and in any case for short period of time (see previous page).</p> <p>At any rate the part load operation requires specific actions to prevent:</p> <ul style="list-style-type: none"> ✓ The insufficient return of oil due to the reduced speed of the gas; ✓ Higher temperatures on the discharge side, caused by the compression lower efficiency and by the lower refrigerant mass flow; ✓ An overheating of the electrical motor that might occur whenever the tension value is out of the given range. <p>Thorough and extensive testing is recommended.</p>
---	--

3.2 SRC-XS series

For the SRC-XS series the capacity control is now obtained by the new configuration L2, while in the past L1 was the capacity control system. The difference between these two configurations is basically the number of the capacity steps. As a matter of fact for:

- ✓ L1 configuration: one only solenoid valve and two capacity steps (50-100%);
- ✓ L2 configuration: two solenoid valves and three capacity steps (50-75-100%);

Hereinafter are described the working principle of the two different configurations.

3.2.1 L1 configuration: working principle and control circuit

With reference to picture 3-Q, the capacity is controlled by the pistons (1) which, exploiting the high or low pressure through just one solenoid valve (the number 20), open or close the internal passageways (2). These passageways bypass part of the fluid compressed by the rotors (50%) directly to the suction side. Consequently only 50% of the mass flow reaches the discharge side. Bypassing part of the mass flow processed by the compressor thus controls the cooling capacity.

Hereinafter the 50% and 100% load capacity steps are considered.

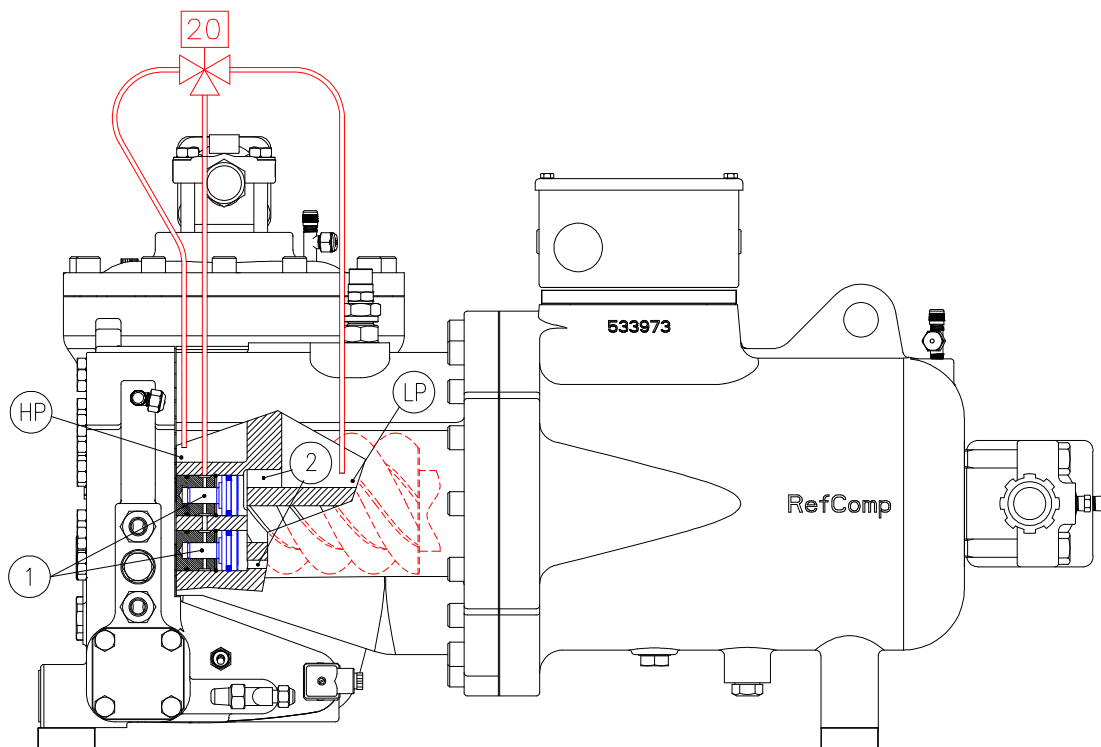

Picture 3-Q: working principle for the capacity control on SRC-XS series compressors: L1 configuration;
20: solenoid valve for controlling the 50 and 100% capacity steps;
1: pistons activated by the refrigerant-oil mixture to bypass the mass flow to the suction side;
2: passageways to bypass the refrigerant to the suction side;
HP: high pressure (discharge side);
LP: low pressure (suction side);

✓ **50% CAPACITY**

With reference to picture 3-R, the solenoid valve (20) is energised, making the cylindrical chambers, that house the pistons, communicate into the low pressure suction side. Due to the higher pressure in the compression chambers (intermediate pressure between suction and discharge) the pistons move and open the passageways that bypass 50% of the flow to the suction side (the red arrows in the picture show the movement). This ensures operation at part load.

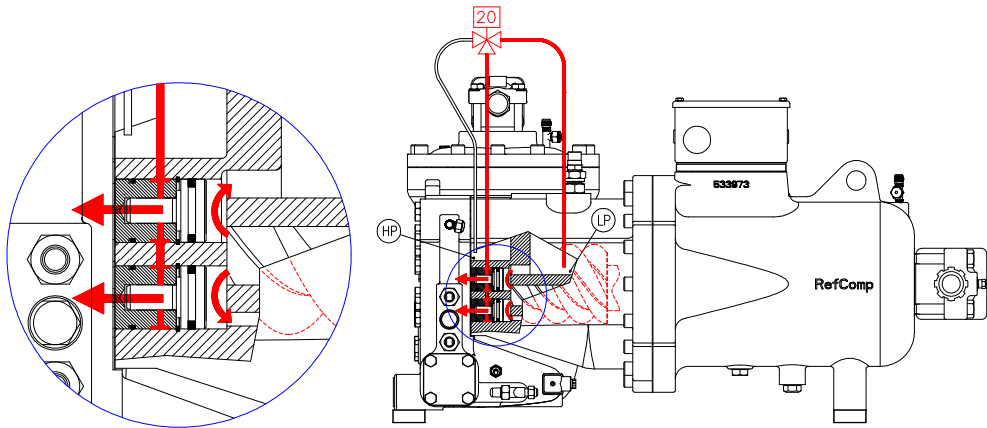

**Picture 3-R: 50% capacity control: L1 configuration;
LP: low pressure;**

✓ **100% CAPACITY**

In this case and with reference to picture 3-S, the solenoid valve (20) is not energised and as a consequence the cylindrical chambers communicate into the high pressure discharge side. Due to the higher pressure here than the intermediate pressure in the compression chamber, the pistons move (the red arrows show the movement) closing the passageways that bypass the fluid. The entire flow of refrigerant processed by the compressor thus reaches the discharge, meaning operation at 100% load.

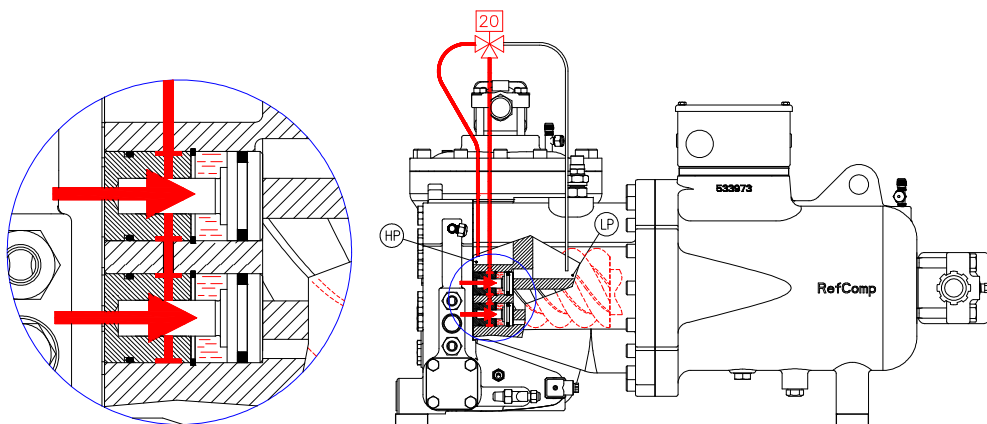

**Picture 3-S: 100% capacity control: L1 configuration;
HP: high pressure;**

3.2.2 L2 configuration: working principle and control circuit

With reference to picture 3-T, the working principle is that already described in the previous paragraph. But now there are two solenoid valves instead of one. They are marked by the numbers 20 and 21, and each of them controls a single piston (1). So now the two pistons are independent and each one allows the by-pass of the 25% of the refrigerant mass flow. Via the solenoid valves is then possible to assure either the 75% or the 50% of the cooling capacity. Hereinafter are described the three possible capacity steps: 50%, 75% and 100%.

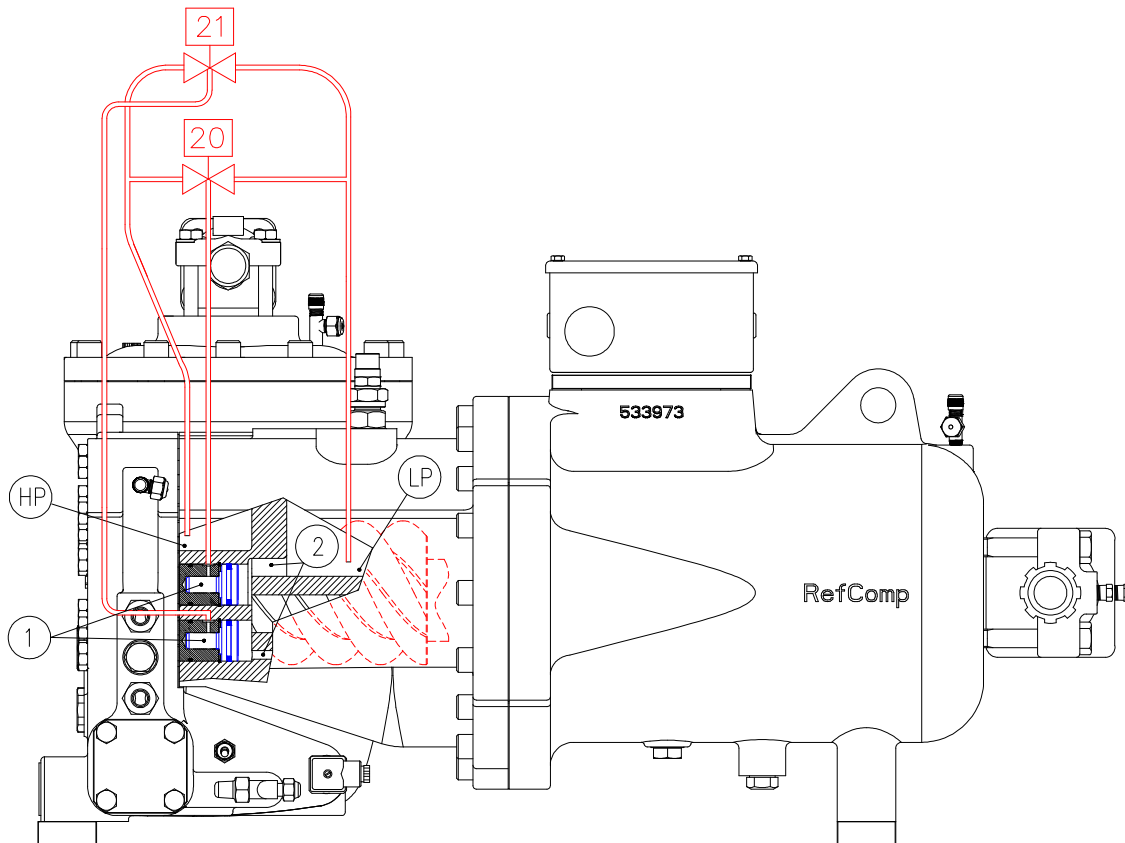

Picture 3-T: working principle for the capacity control on SRC-XS series compressors: L2 configuration;
20, 21: solenoid valves for controlling the 50, 75 and 100% capacity steps;
1: pistons activated by the refrigerant-oil mixture to bypass the mass flow to the suction side;
2: passageways to bypass the refrigerant to the suction side;
HP: high pressure discharge;
LP: low pressure suction;

✓ 50% CAPACITY

With reference to picture 3-U, both the solenoid valves (20) and (21) are energised, making the cylindrical chambers that house the pistons communicate into the low pressure suction side. The pistons, then, due to the higher pressure in the compression chamber (intermediate pressure between suction and discharge) move (the red arrows show the movement), opening both the passageways that bypass 50% of the flow to the suction side. This ensures operation at 50% part load.

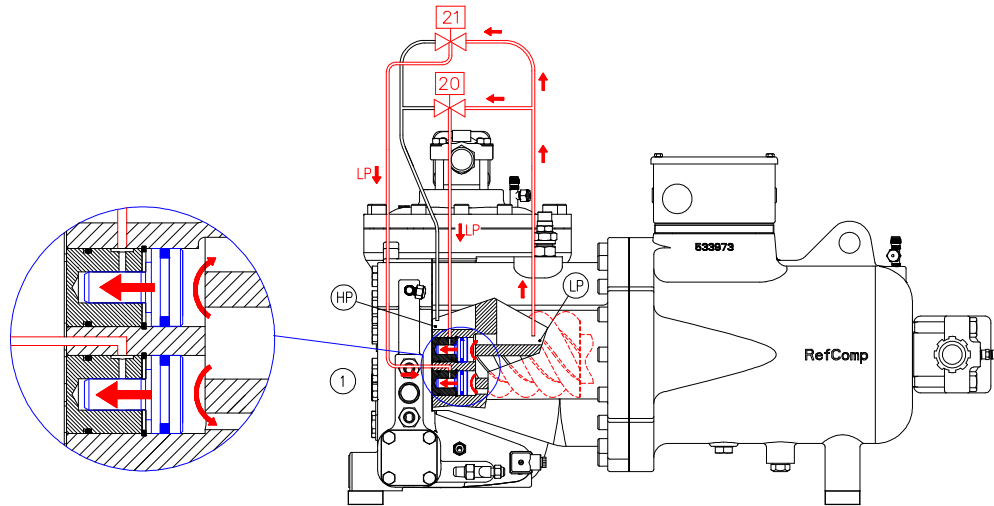

**Picture 3-U: 50% capacity control: L2 configuration;
LP: low pressure;**

✓ 75% CAPACITY

By looking at picture 3-V, the solenoid valve (21) remains energised so that the related lower piston opens the passageway for the by-pass of the 25% of the flow to the suction side. The solenoid valve (20) instead is de-energised and its related upper piston closes the other by-pass passageway (the red arrows show the movement of the pistons). That way only one piston assures the mass flow by-pass and consequently the discharge mass flow is 75% of the total one.

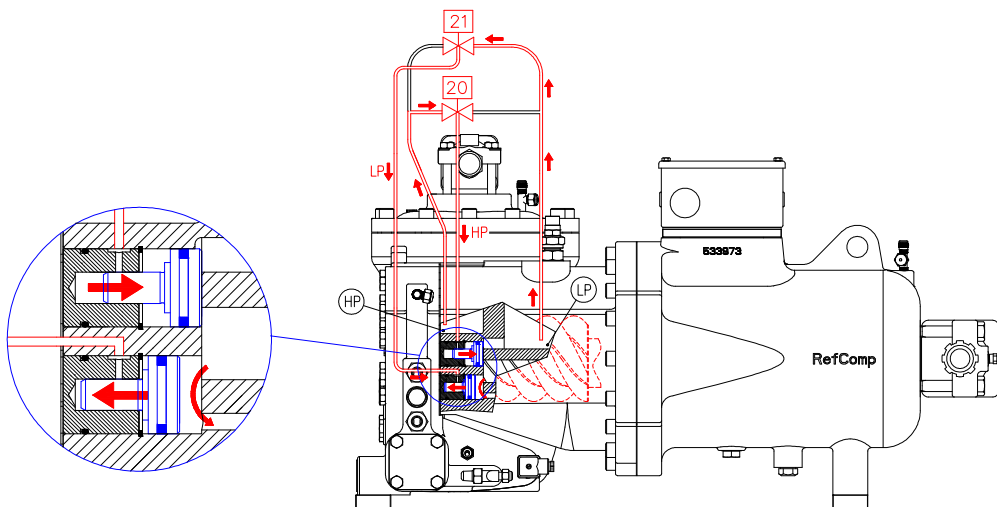

**Picture 3-V: 75% capacity control: L2 configuration;
LP: low pressure;
HP: high pressure;**

✓ **100% CAPACITY**

With reference to picture 3-X, both the solenoid valves (20) and (21) are not energised and as a consequence the cylindrical chambers communicate into the high pressure discharge side. Due to the higher pressure here than the intermediate pressure in the compression chamber, the pistons move (the red arrows show the movement) closing both the passageways that bypass the fluid. The entire flow of refrigerant processed by the compressor thus reaches the discharge, meaning operation at 100% load.

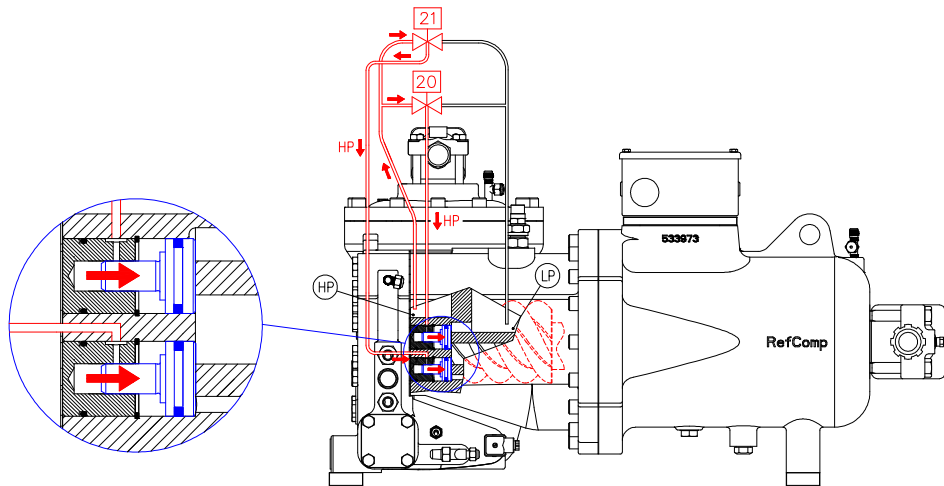

**Picture 3-X: 100% capacity control: L2 configuration;
HP: high pressure;**

3.2.3 Control sequence: step configuration

The capacity control is achieved by the solenoid valves (20) and (21) which are located on the top of the compressor casing, see picture 3-Y. In Table C is shown how to energise the solenoid valves.

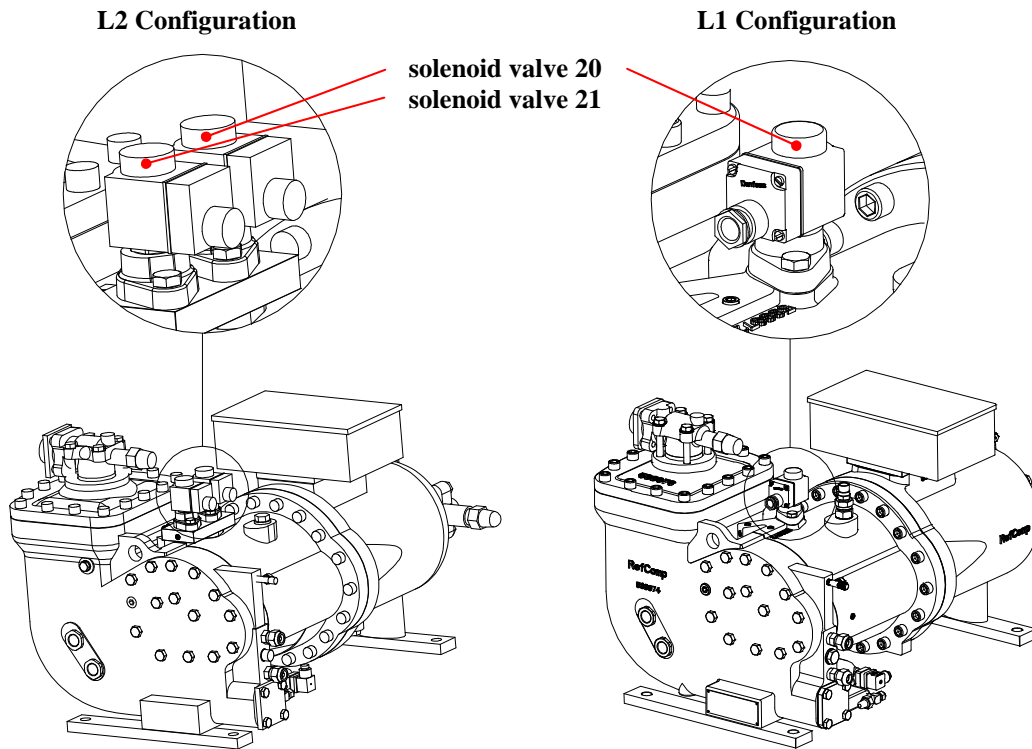

Picture 3-Y: position of the solenoid valves (20) and (21) for capacity control in the series SRC-XS compressors;

Capacity	L1	L2	
	Solenoid valve	Solenoid valves	
	20	20	21
100%	OFF	OFF	OFF
75%	-	OFF	ON
50%	ON	ON	ON

OFF = solenoid not energised; ON = solenoid energised;

Table C: operating logic of the solenoid valves for step capacity control;

3.3 Procedure for starting and stopping the compressor

To limit the peak current when starting, the electric motors are started in the part-winding configuration, or alternatively with the windings connected in the star configuration (see chapter EA-05: *'Electrical devices'*). This, however, means also a drop in the starting torque, and as a result the resisting torque needs to be reduced in order to start the compressor without excessively overloading the electric motor. For this purpose, Refcomp recommends to start the compressors at the minimum capacity step, see Figure 3-Z.

Concerning the SRC-S series compressors, distinction needs to be made between the step and the stepless configuration.

In the configuration with 4 steps the slide valve automatically returns to the position of minimum capacity after the compressor stops. In fact due to the pressure difference the oil can flow out of the cylinder to the crankcase through the pipe marked by number 20, see picture 3-A or through the pipe marked by numbers 3 and 4 for the compressors 255/285/305/755/785/885/985, see picture 3-B. Therefore the compressor can start again at the minimum capacity.

In the infinite configuration, on the other hand, this pipe is closed by the solenoid valve (19), see picture 3-N, which is normally closed (or by the solenoid valve (16) in the models 255/285/305/755/785/885/985, see picture 3-O). Consequently, unless the solenoid valve (14) is energized before stopping, the oil cannot flow out of the cylinder and as a result the compressor is not discharged.

For this reason, so as to stop and re-start the compressor at the minimum capacity step the valve (14) must be energized for around 25 seconds before switching off the compressor, see picture 3-Z. Moreover the valve (14) should be kept energized during the compressor standstill periods.

The starting and stopping procedure indicated in picture 3-Z has to be followed for all the screw compressors, both in the step and in the stepless version, as this avoids noisy stopping due to the temporary reverse rotation with high mass flow.

	<p>Warning!</p> <p>If having to shutdown in an emergency, the compressor will stop at the current capacity step. In the stepless configuration then, before restarting the unit, make sure that the compressor is at the minimum capacity step.</p>
--	--

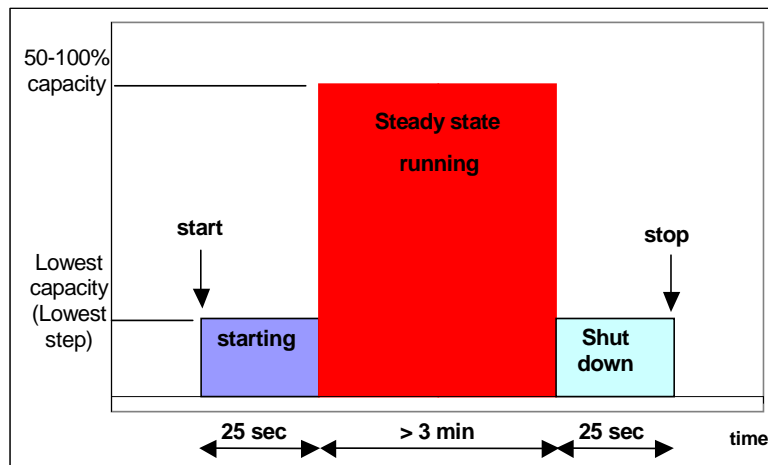

Picture 3-Z: starting and stopping the compressor;

Concerning the SRC-XS series compressors, which are not fitted with the capacity control slide valve and do not need to empty any hydraulic cylinder, it is just necessary to start them with both the solenoid valves 20 and 21 energized for 25 sec.

3.4 Operating limits at part load

Operation at part load increases the discharge temperature (it is recommended not to exceed 110° C) and has a slightly lower efficiency than at full load.

In particular, the discharge temperature increases if:

- The condensing pressure increases;
- The evaporation pressure decreases;
- The temperature of the suction gas (superheat) increases.

To define the operating limits at part load, see chapter SA-10: “*Application range*”.

SRC-XS and SRC-S series compressors

Components (SA-04-06-E)

4	COMPONENTS	2
4.1	SUCTION FILTER	2
4.2	SAFETY VALVE	2
4.3	CHECK VALVE	3
4.4	RUBBER VIBRATION DAMPER	3
4.5	OIL FLOW SWITCH	6

4 Components

4.1 Suction filter

The compressors SRC-XS-40/50/60 and SRC-S-183/213/253/255/285/303/305/353/413/463/785/885/985 are fitted with a suction filter that can be inspected and cleaned by simply dismantling the suction shut-off valve. For the remaining models SRC-S-113/133/163/503/553/603/755, the filter must be cleaned by opening the sump on the compressor from the suction side. Picture 4-A shows the suction filters used in the different compressors.

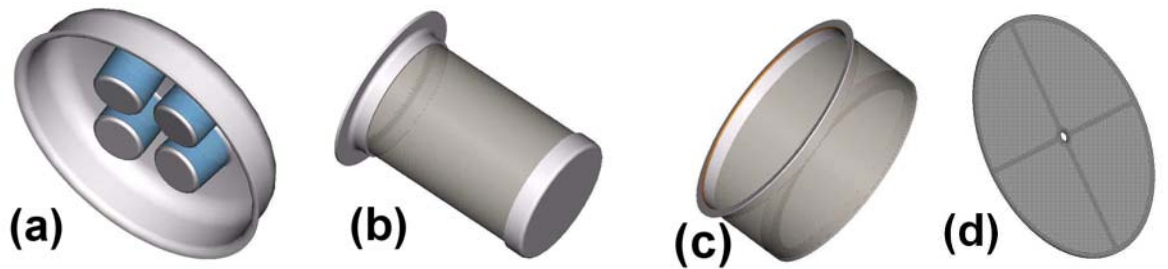

Picture 4-A: suction filter: a) models: SRC-S-113/133/163; b) SRC-XS series and models SRC-S-183/213/253/255/285/303/305/353/413/463; c) models SRC-S-503/553/603/755 d) SRC-S-785/885/985;

4.2 Safety valve

The compressors are fitted with a safety valve that when necessary opens a passageway between the high and low pressure sections, see picture 4-B. The valve is sized in accordance with the European standard EN 60335-2-34. The safety valve opens when the pressure differential, between discharge and suction, exceeds 26 bar, and closes again automatically.

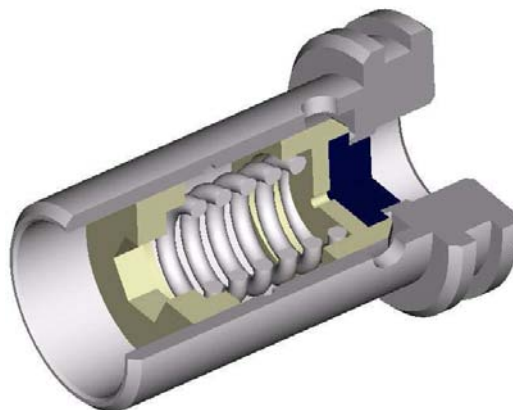

Picture 4-B: safety valve;

4.3 Check valve

To avoid the backflow of the gas when the compressor stops, due to the pressure difference, the compressor is fitted with a check valve installed immediately upstream of the discharge shut-off valve, see picture 4-C.



Warning!

When the compressor stops, following the balancing of the pressure, there is a temporary reverse rotation of the rotors, which produces a typical noise. If this noise lasts more than 3 seconds, check and if necessary replace the check valve.

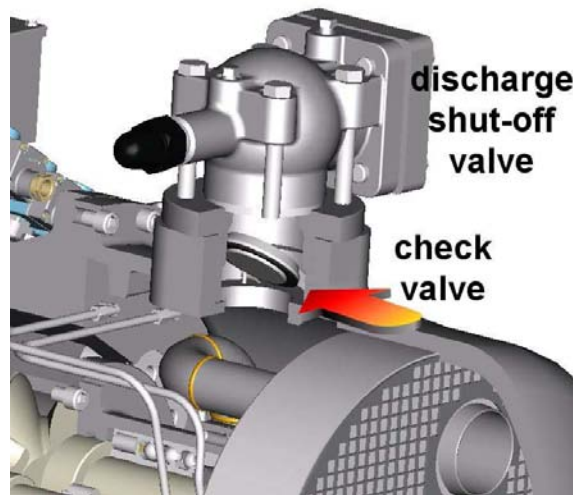

Picture 4-C: check valve;

4.4 Rubber vibration damper

Picture 4-D below shows the location of the rubber vibration dampers underneath the 4 feet of the SRC-XS and SRC-S compressor.

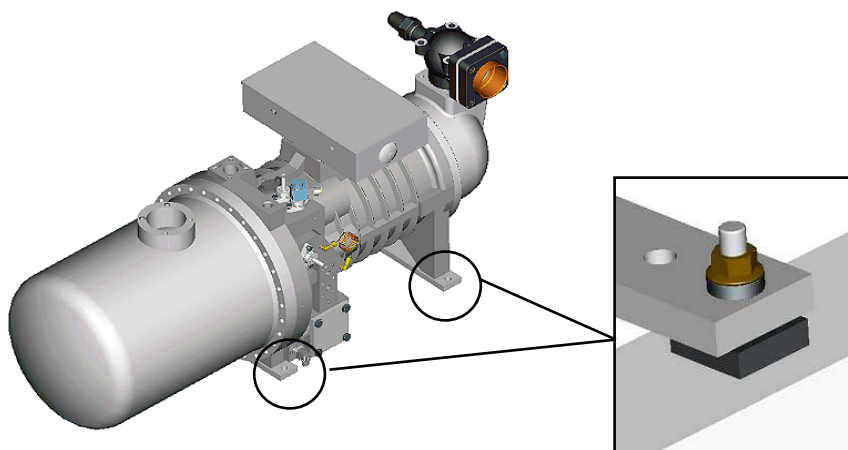

Picture 4-D: position of the rubber vibration damper underneath the 4 feet of the compressors;

In order to completely fulfil their purpose the vibration dampers must be compressed as little as possible and the exact tightness of the self-locking bolt is achieved when the deformed vibration damper bushing is around 0.5 mm less than its size when relaxed.

Picture 4-E and 4-F respectively show a photo that indicates the correct assembly of the vibration damper, and the assembly diagram for all the components included in the kit.

Below are the codes of the vibration damper kit for all the series models.

- ✓ Models SRC-XS-40/50/60 and SRC-S-113/133/163/183/213/253/255/285/303/305: kit n° 303243;

Components:

Assembly diagram for the vibration damper kit	n° 585897
4 vibration damper bushings (hardness 55°Sh, Neoprene, black)	n° 592742
4 soft damper pads (hardness 45°Sh, Neoprene, white)	n° 592749
4 x grade 8G M14 flanged lock nuts	n° 614517
4 x grade 8.8 M14 x 70 screws	n° 614525

- ✓ Models SRC-S-353/413/463/503/553/603/755/785/885/985: kit n° 303321;

Components:

Assembly diagram for the vibration damper kit	n° 585897
4 vibration damper bushings (hardness 55°Sh, Neoprene, black)	n° 592742
4 damper pads (hardness 70°Sh, Neoprene, black)	n° 591140
4 x grade 8G M14 flanged lock nuts	n° 614517
4 x grade 8.8 M14 x 70 screws	n° 614525



Picture 4-E: correct assembly of the vibration dampers;

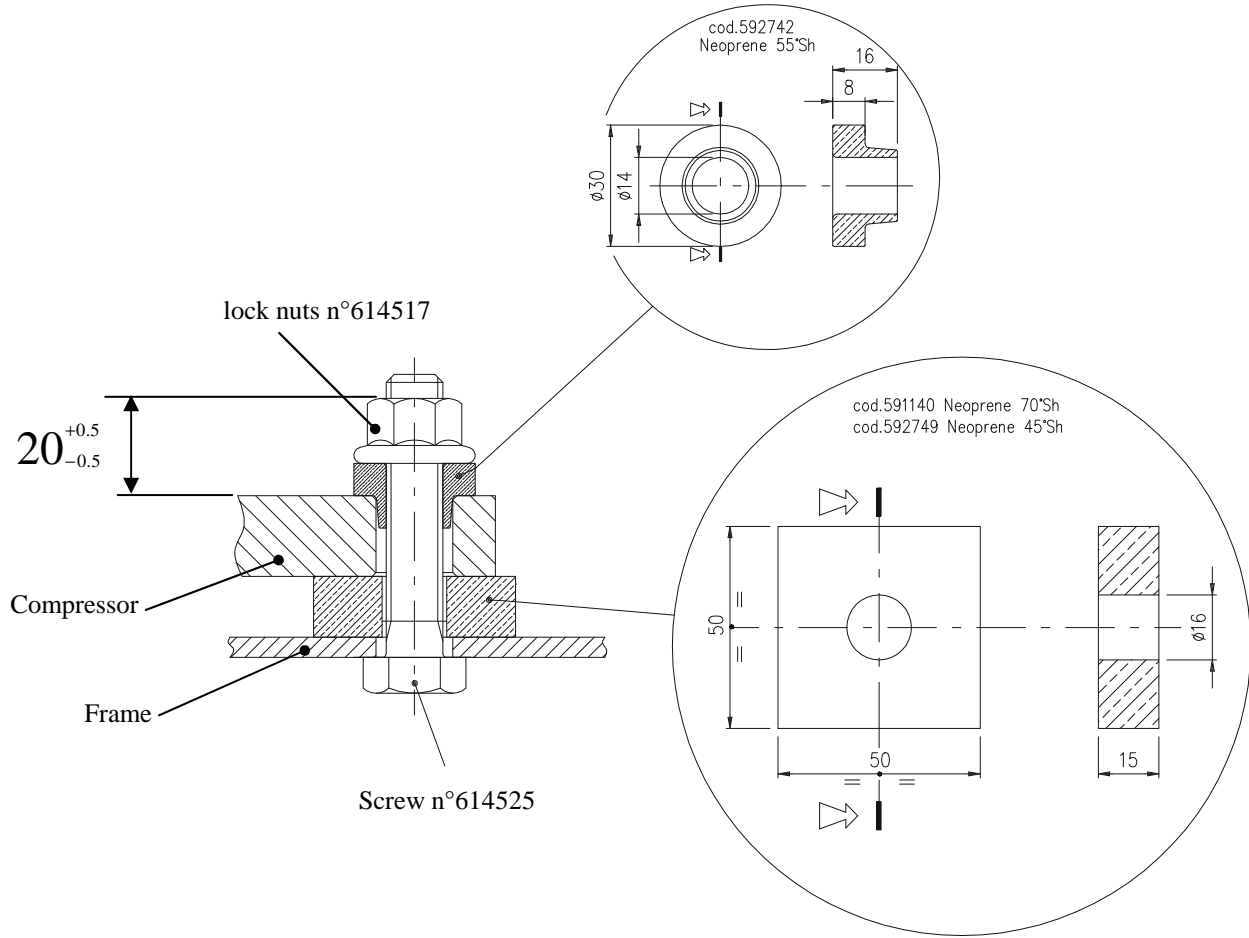

Fig Picture 4-F: assembly diagram for the rubber vibration dampers;

4.5 Oil flow switch

The flow switch kit is available upon request to check the correct circulation of the oil in the compressor. The following kits are available, depending on the model:

- ✓ Models SRC-S-113/133/163/183/213/253/303 kit n° 303674;

components:	n° 2 oil inlet hoses	n° 519067
	oil cooling plate	n° 519190
	flow switch kit assembly diagram	n° 585921
	plate gasket	n° 592741
	n° 2 1/8" NPT caps	n° 610680
	n° 4 straight connections	n° 614474
	n° 6 M8 x 30 screws	n° 614538
	flow switch FF-015RAS-20	n° 680345
	n° 4 Teflon gaskets	n° 691090

For the same models is also available the Kit 303816, that includes, in addition:

N° 1 INT 69 VS motor protector	n° 581250
N° 1 220 mF, 63V electrolytic capacitor	n° 680334

- ✓ Models SRC-S-353/413/463/503/553/603 kit n° 303675;

components:	n° 2 oil inlet hoses	n° 519067
	oil cooling plate	n° 519226
	flow switch kit assembly diagram	n° 585921
	plate gasket	n° 592750
	1/8" NPT caps	n° 610680
	n° 4 straight connections	n° 614474
	n° 6 M10x30 screw	n° 613900
	flow switch FF-015RAS-17	n° 680346
	n° 4 Teflon gaskets	n° 691090

For the same models is also available the Kit 303817, that includes, in addition:

N° 1 INT 69 VS motor protector	n° 581250
N° 1 220 mF, 63V electrolytic capacitor	n° 680334

- ✓ Models SRC-XS-40/50/60 and SRC-S-255/285/305 kit n° 303690;

components:	flow switch kit assembly diagram	n° 585929
	n° 2 straight connections	n° 614474
	flow switch FF-015RAS-20	n° 680345
	n° 2 Teflon gaskets	n° 691090

For the same models is also available the Kit 303818, that includes, in addition:

N° 1 INT 69 VS motor protector	n° 581250
N° 1 220 mF, 63V electrolytic capacitor	n° 680334

✓ Models SRC-S-755/785/885/985 kit n° 303799;

components: flow switch kit assembly diagram	n° 585952
n° 2 straight connections	n° 614474
flow switch FF-015RAS-17	n° 680346
n° 2 Teflon gaskets	n° 691090

For the same models is also available the Kit 303818, that includes, in addition:

N° 1 INT 69 VS motor protector	n° 581250
N° 1 220 mF, 63V electrolytic capacitor	n° 680334

The following pictures 4-R, 4-S, 4-T, 4-U, 4-V, 4-W e 4-X show the assembly diagrams for all the components included in the kit and the correct assembly of the kit on the compressor. The components must be assembled as illustrated in the figures, checking the correct direction of the oil flow as indicated by the arrow on the flow switch. Figures 4-Y and 4-Z, on the other hand, show the wiring diagram for the connection of the flow switch to the INT 69 VS protection module.

As regards the technical specifications for the INT 69 VS protection module, see chapter SA-05: “*Electrical devices*”. The flow switches have the following characteristics:

Technical specifications of the flow switch:

Switch value: 6 l/min H₂O (n° 680345) and 10 l/min H₂O (n° 680346);

Voltage supply: 250V a.c. – 1A – 50VA; Max temperature: 100°C;

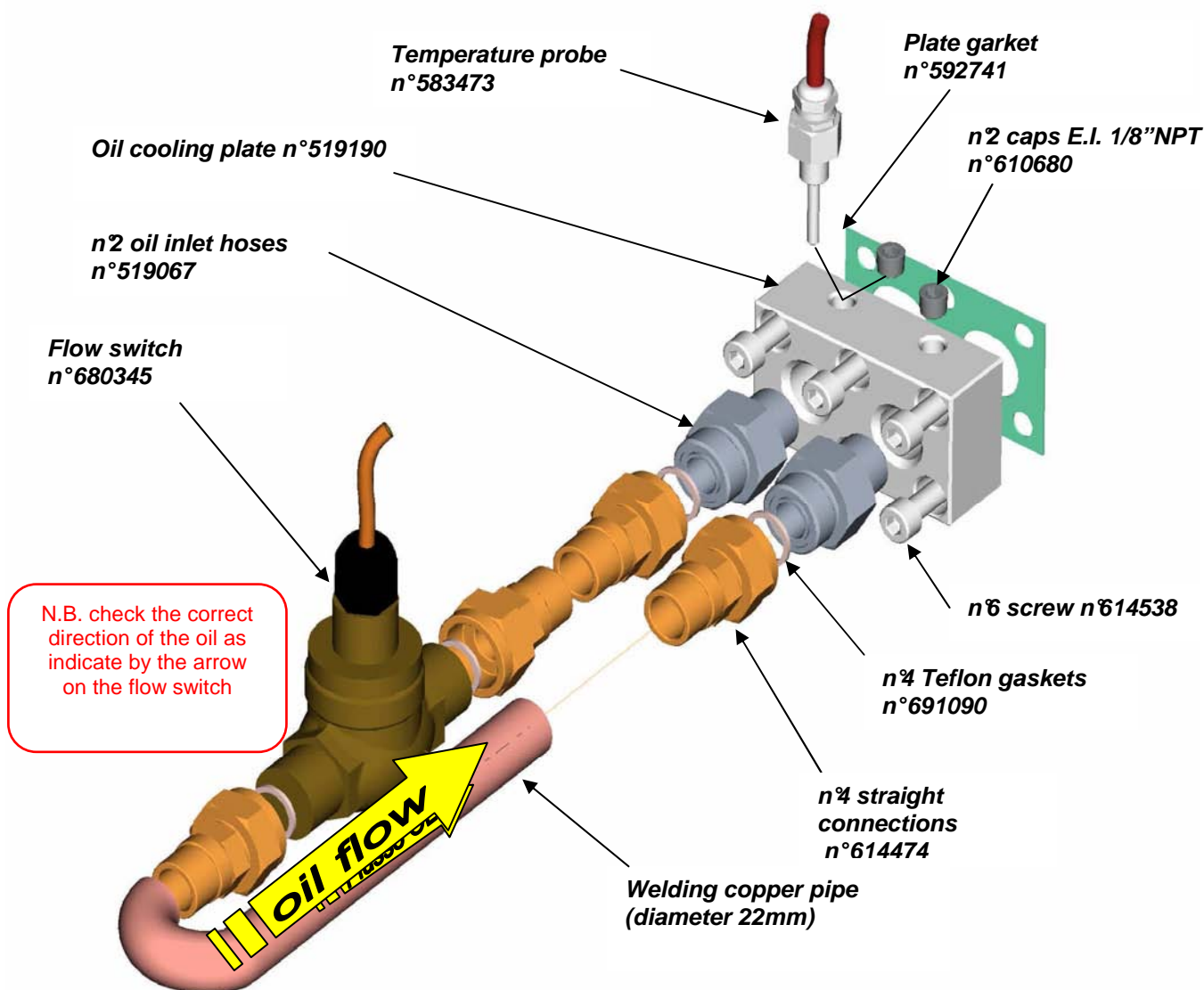

Picture 4-R: Assembly of the components in flow switch kit 303674: models SRC-S-113/133/163;

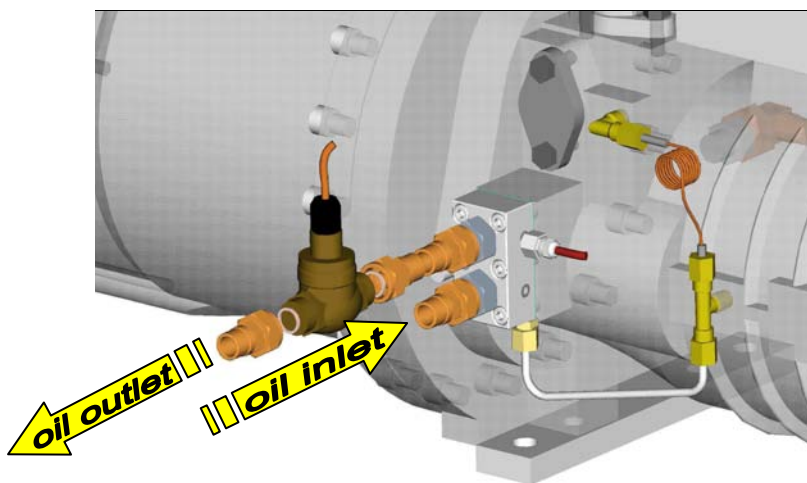

Picture 4-S: Installation of the kit 303674 on the compressor: models SRC-S-113/133/163;

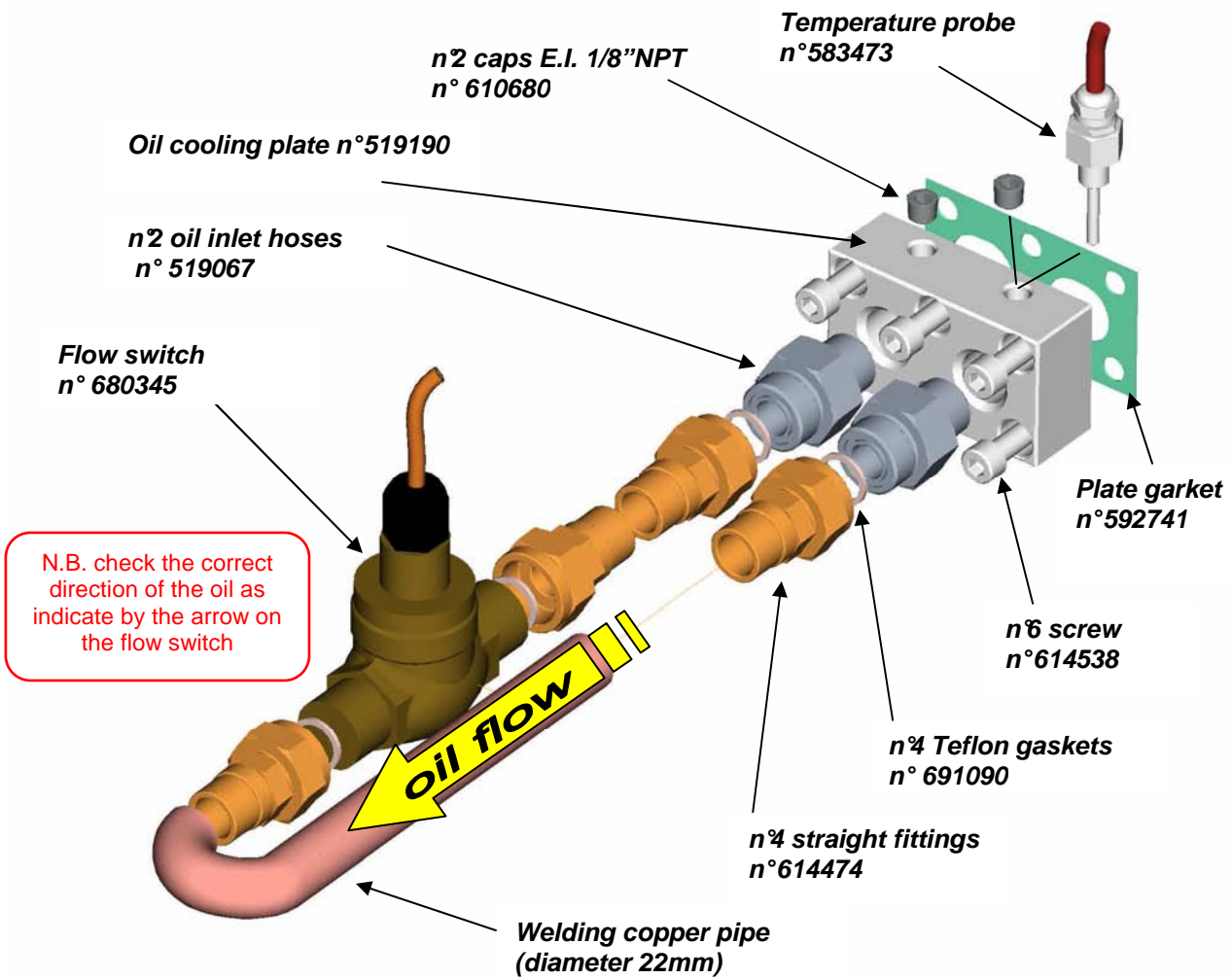

Picture 4-T: Assembly of the components in flow switch kit 303674: models SRC-S-183/213/253/303;

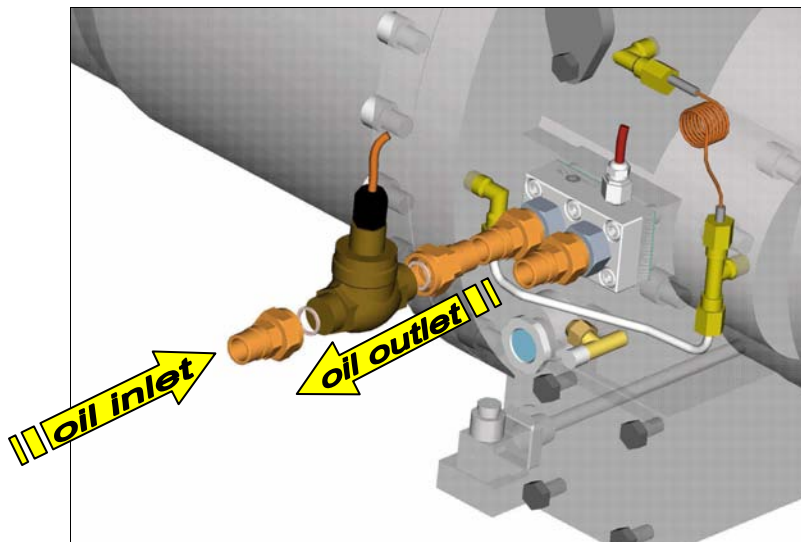

Picture 4-U: Installation of the kits 303674 and 303675 on the compressor: models SRC-S-253/303/353/413/463;

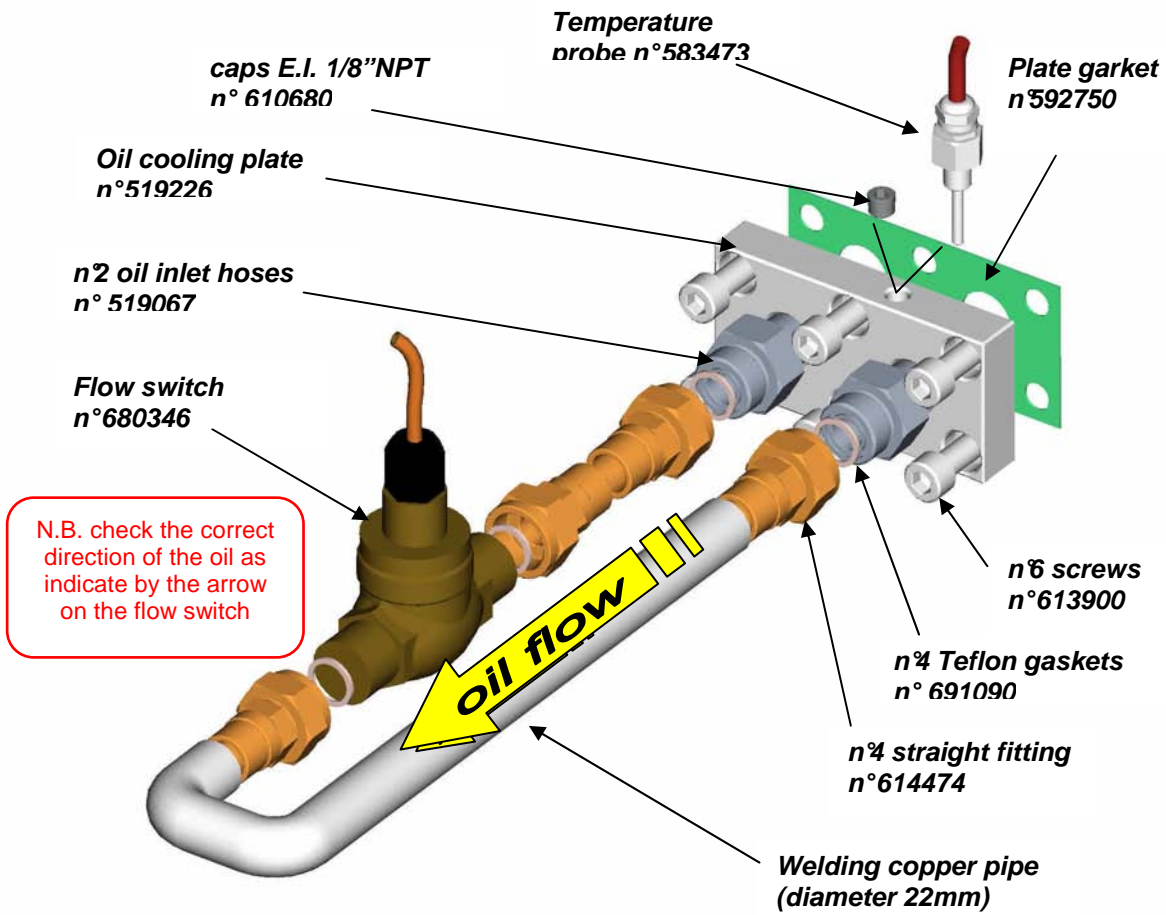

Picture 4-V: Assembly of the components in flow switch kit 303675: models SRC-S-353/413/463/503/553/603;

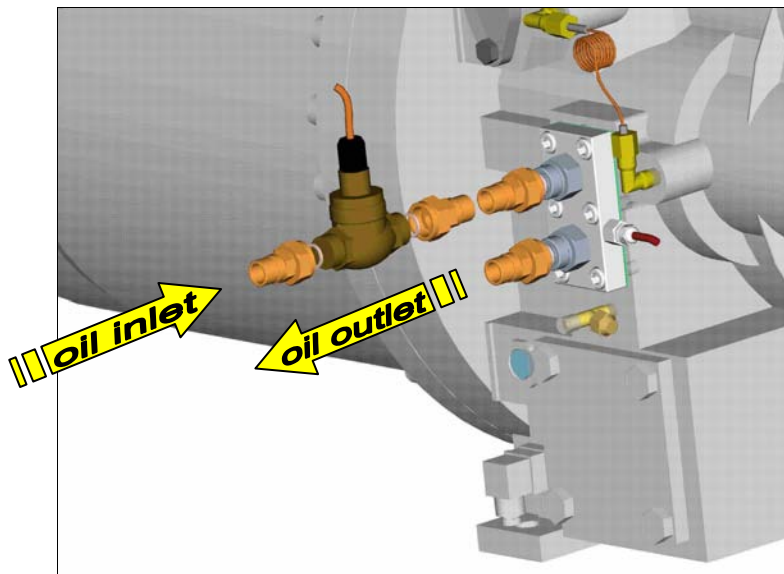

Picture 4-W: Installation of the kits 303674 and 303675 on the compressor: models SRC-S-183/213/503/553/603;

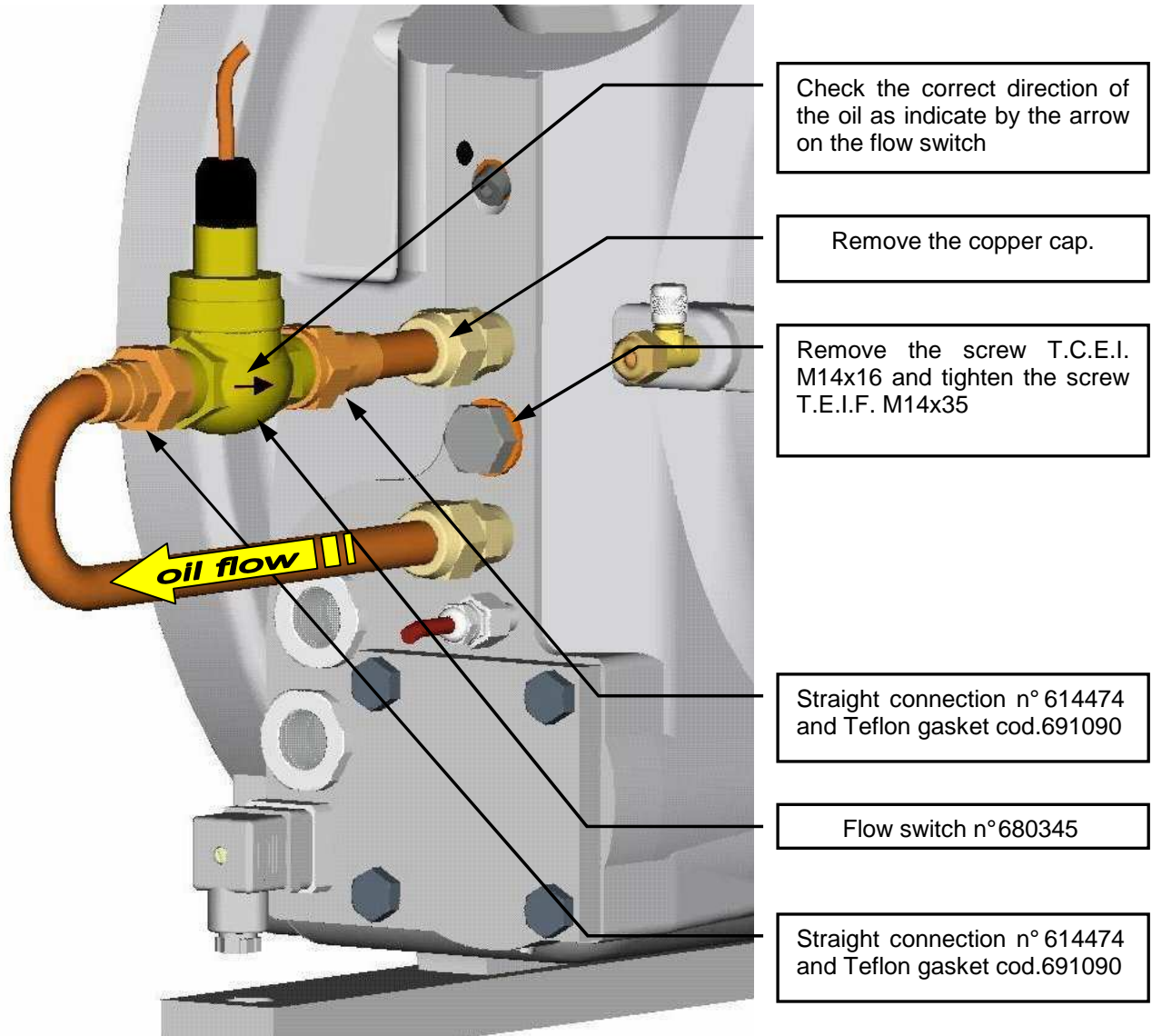

Picture 4-X: Installation of the kit 303690 on the compressor: models SRC-XS-40/50/60 and SRC-S-255/285/305/755/785/885/985;

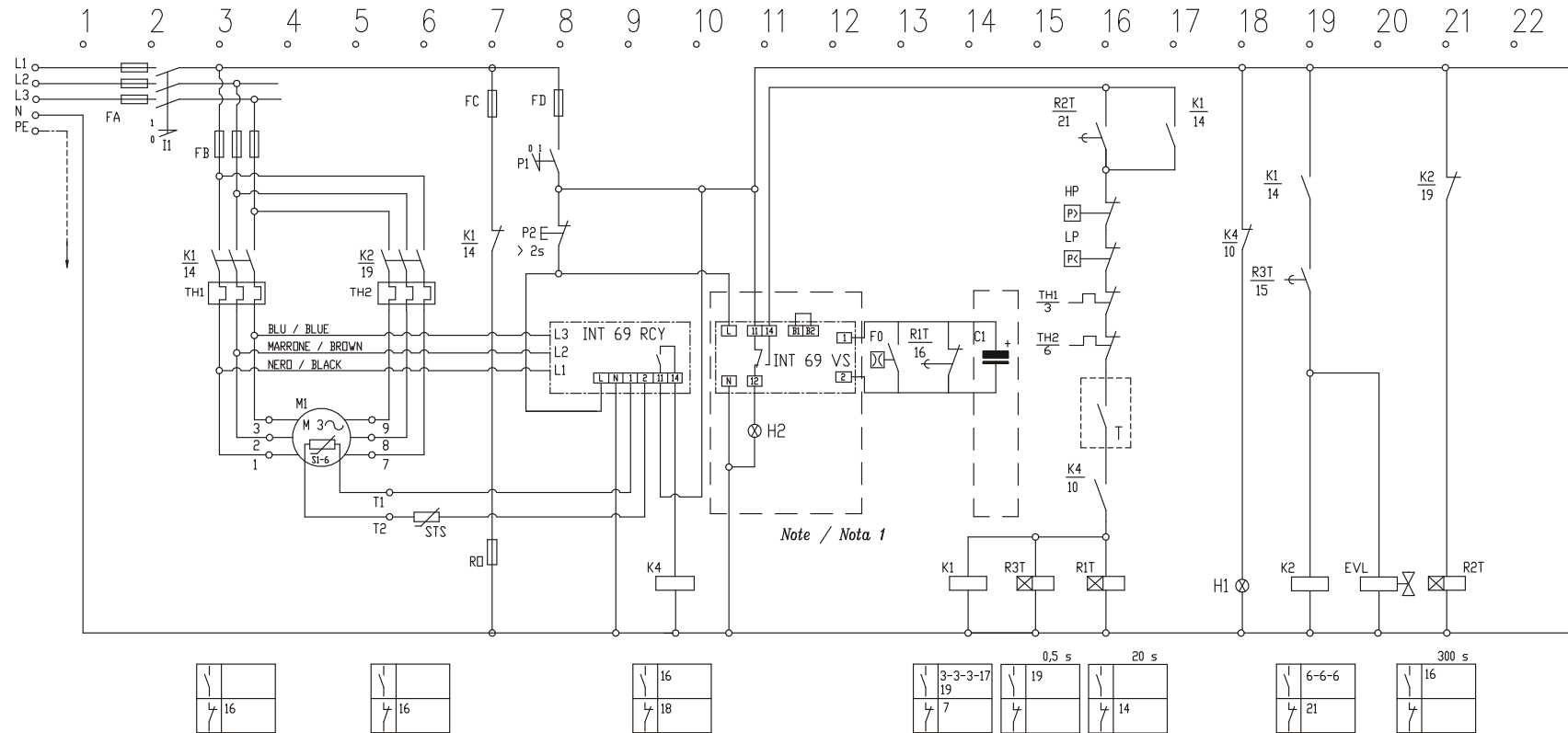

KEY:

- | | | | |
|-----|-----------------------------------|------|---------------------------------|
| T | CONTROL THERMOSTAT | M | COMPRESSOR |
| FA | MAIN FUSE | H | MAIN SWITCH |
| FB | COMPRESSOR FUSE | RO | OIL HEATER |
| FC | CONTROL CIRCUIT FUSE (OIL HEATER) | STS | DISCHARGE TEMPERATURE SENSOR |
| FD | CONTROL CIRCUIT FUSE | ST-6 | MOTOR TEMPERATURE SENSOR |
| HP | HIGH PRESSURE SWITCH | P1 | ON-OFF SWITCH |
| LP | LOW PRESSURE SWITCH | P2 | MOTOR PROTECTION RESET |
| H1 | SIGNAL LAMP (MOTOR PROTECTION) | EVL | SOLENOID VALVE (LIQUID LINE) |
| K1 | START CONTACTOR | H2 | SIGNAL LAMP (OIL FLOW FAULT) |
| K2 | RUN CONTACTOR | R1T | TIME RELAY (OIL FLOW CONTROL) |
| R2T | TIME RELAY "PAUSE TIME" | CI | ELECTROLYTIC CAPACITOR |
| R3T | TIME RELAY START - RUN | F0 | OIL FLOW SWITCH |
| K4 | MOTOR PROTECTION RELAY | TH1 | RELAY OVERCHARGE FIRST WINDING |
| | | TH2 | RELAY OVERCHARGE SECOND WINDING |

wiring diagram for the connection of the flow switch; electric motor with part-winding configuration PW (MCE007\$2);

Note 1: INT 69 VS and electrolytic capacitor included only in kit cod. 303816, 303817 and 303818.

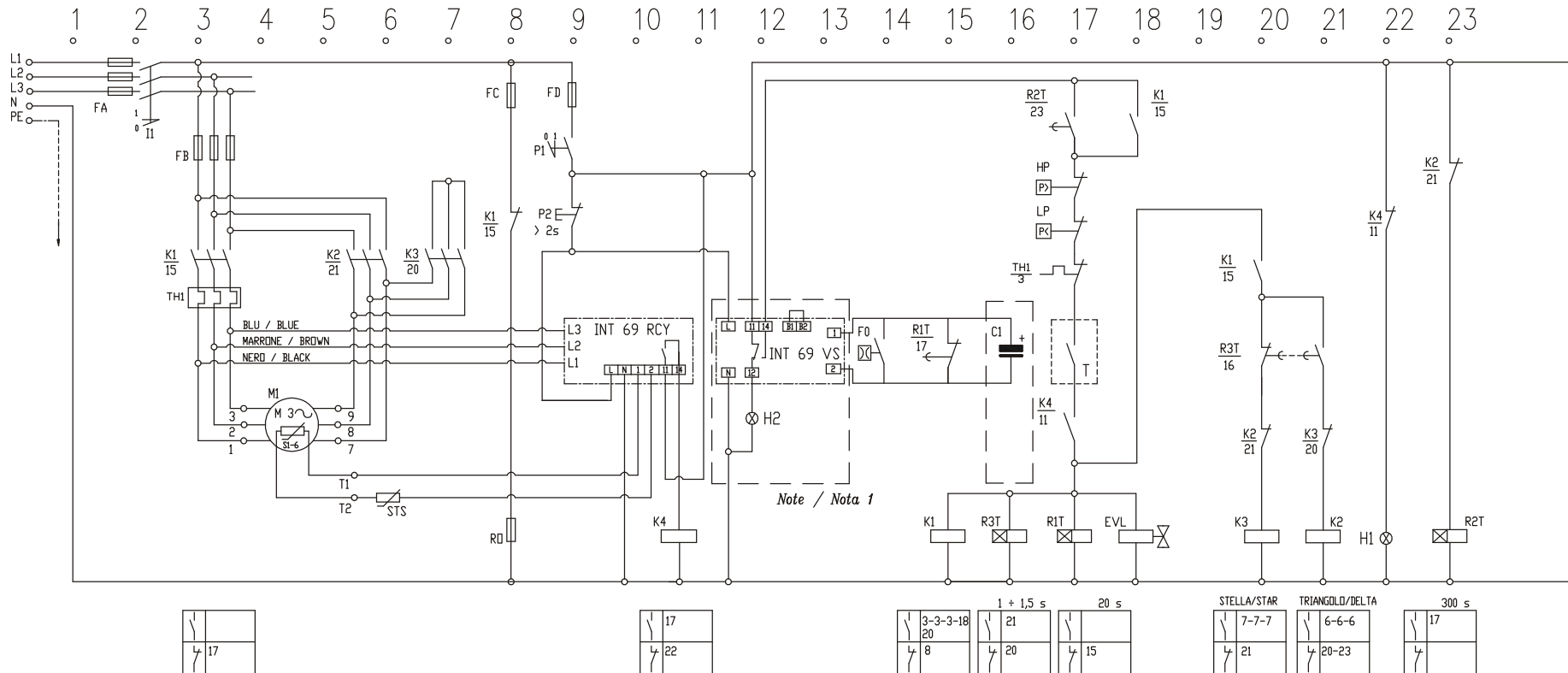

KEY:

- | | |
|---|--|
| <p>T CONTROL THERMOSTAT
FA MAIN FUSE
FB COMPRESSOR FUSE
FC CONTROL CIRCUIT FUSE (OIL HEATER)
FD CONTROL CIRCUIT FUSE
HP HIGH PRESSURE SWITCH
LP LOW PRESSURE SWITCH
H1 SIGNAL LAMP (MOTOR PROTECTION)
K1 START CONTACTOR
K2 RUN CONTACTOR
K3 WYE CONTACTOR
R2T TIME RELAY "PAUSE TIME"
R3T TIME RELAY START - RUN
K4 MOTOR PROTECTION RELAY</p> | <p>M1 COMPRESSOR
II MAIN SWITCH
RO OIL HEATER
STS DISCHARGE TEMPERATURE SENSOR
SI-6 MOTOR TEMPERATURE SENSOR
PI ON-OFF SWITCH
P2 MOTOR PROTECTION RESET
EVL SOLENOID VALVE (LIQUID LINE)
H2 SIGNAL LAMP (OIL FLOW FAULT)
R1T TIME RELAY (OIL FLOW CONTROL)
C1 ELECTROLYTIC CAPACITOR
FO OIL FLOW SWITCH
TH1 RELAY OVERCHARGE MOTOR</p> |
|---|--|

Picture 4-Z: wiring diagram for the connection of the flow switch; electric motor with star-delta configuration YΔ (MCE008\$2);

Note 1: INT 69 VS and electrolytic capacitor included only in kit cod. 303816, 303817 and 303818.

SRC-XS and SRC-S series compressors

Electrical devices

(SA-05-11-E)

5. ELECTRICAL MOTOR	2
5.1 GENERAL	2
5.2 PROTECTION DEVICES	5
5.2.1 <i>Motor thermistors</i>	5
5.2.2 <i>INT 69 VS</i>	5
5.2.3 <i>INT 69 RCY</i>	7
5.3 POWER SUPPLY	11
5.4 SELECTION OF ELECTRICAL COMPONENTS	12
5.5 SIZE OF THE MOTOR	12
5.6 TECHNICAL DATA	13

5. Electrical motor

5.1 General

The electric motors are three-phase asynchronous two-pole motors (2900 rpm at 50 Hz). To reduce the peak current, they are available in the part-winding (PW) or star/delta (Y/ Δ) version; for the standard supply see Table C in paragraph 5.6: Electrical specifications.

Depending on the compressor model there are two different types of PW motors which differ from each other for the connection of the three phases: star or delta type. In any case at the compressor starting only a part of the windings is powered, while in normal operation all are powered. The PW versions can be:

- ✓ Double star (Y-YY);
- ✓ Double delta (Δ - $\Delta\Delta$).

As regards the mains connections, there is no difference between the two PW motor configurations. Pictures 5-A and 5-B below show the internal connections of the phases, depending on the configuration of the electrical motor.

• PART-WINDING CONFIGURATION

	<p>Important note:</p> <p>The two above-mentioned part-winding types of motors can be distinguished by measuring the electrical resistance between terminals 1-2-3 and 7-8-9.</p> <p>With reference to picture 5-A:</p> <ul style="list-style-type: none"> ✓ in the Y-YY configuration there is continuity between terminals 1 and 2, 1 and 3, 2 and 3, 7 and 8, 7 and 9, 8 and 9; while there is insulation between terminals 1 and 7/8/9, 2 and 7/8/9, 3 and 7/8/9. ✓ in the Δ-$\Delta\Delta$ configuration there is continuity between each pair of terminals and there is not reciprocal insulation between any of them.
--	--

PART-WINDING CONFIGURATION

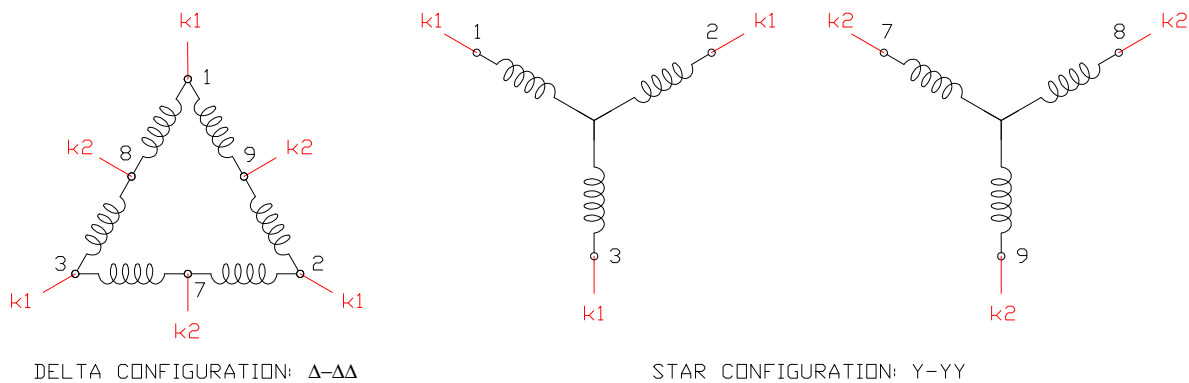

Picture 5-A: internal winding connections for the motors with part-winding configuration;

- STAR-DELTA CONFIGURATION**

	<p>Important note:</p> <p>With reference to picture 5-B, measuring the electrical resistance between terminals 1-2-3 and 7-8-9, the star-delta version has the following values: continuity between terminals 1 and 8, 3 and 7, 2 and 9, and insulation between terminals 1 and 2/3/7/9, 2 and 1/3/7/8, 3 and 1/2/8/9, 7 and 1/2/8/9, 8 and 2/3/7/9, 9 and 1/3/7/8.</p>
--	--

STAR-DELTA CONFIGURATION

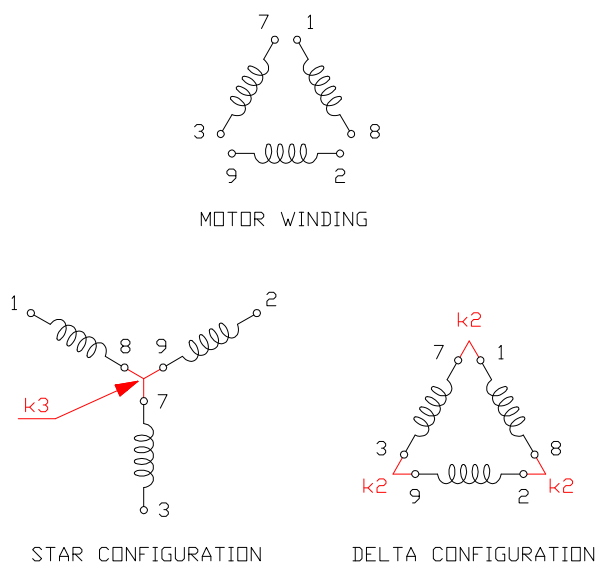

Picture 5- B: internal winding connections for the motors with star-delta configuration;

By starting the electrical motor either in part-winding configuration or with the windings in star connection for the electrical motor in star-delta configuration there is a reduction in the starting current LRA and starting torque. To achieve a reduction in the resisting torque and consequently start the motor without overloading it, the compressor needs to be started at the minimum capacity step, see chapters SA-03: “Capacity control” and SA-13: “Operating instructions”.

	<p>Note:</p> <p>Then with the screw compressors no by-pass system between the high and low pressure is required for reducing the resisting torque on starting.</p>
--	---

Picture 5-C shows how to connect the electrical motor to the three-phase line, both for the star-delta configuration and the part-winding one. It also gives the time sequence for the contactors. The compressor therefore starts as follows:

- ✓ In the PW motors, the delay in closing the run contactor K2 from when the starting contactor K1 closes must be 1 second maximum (recommended value 0.6 sec), see picture 5-C.
- ✓ In the star-delta configuration, on the other hand, the starting duration in star configuration (closing of contactors K1-K3) must not exceed 1.5 sec (recommended value 0.8/1 sec); while when switching to delta configuration (closing of contactors K1-K2), contactor K2 must be closed with a delay of 35-50 msec from the instant when contactor K3 is opened, see picture 5-C again.

STAR-DELTA
CONFIGURATION

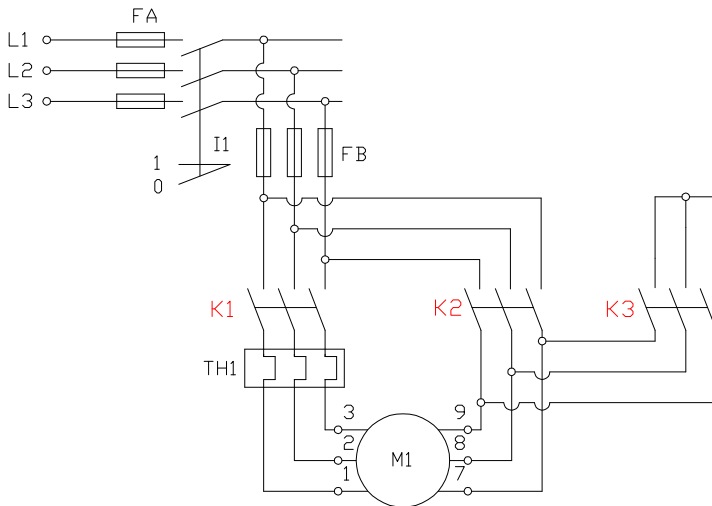

PART-WINDING
CONFIGURATION

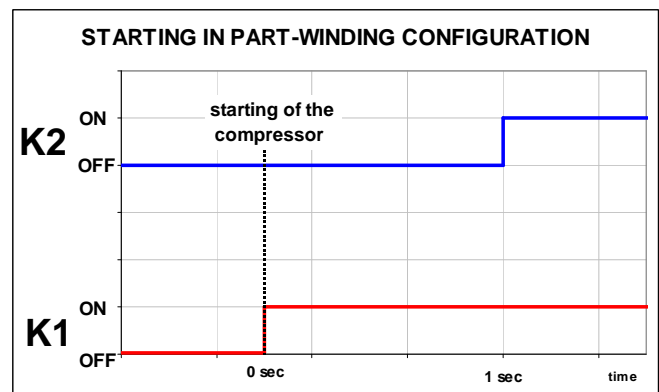
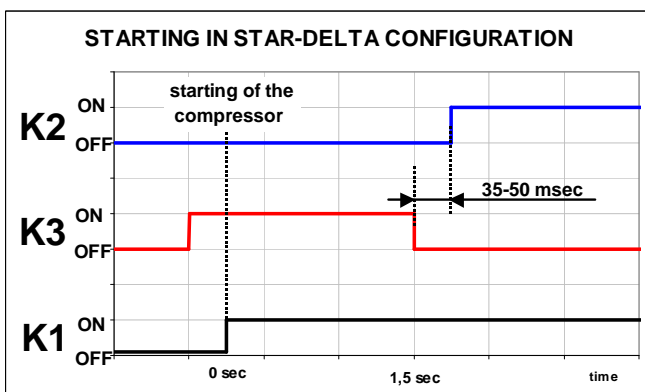
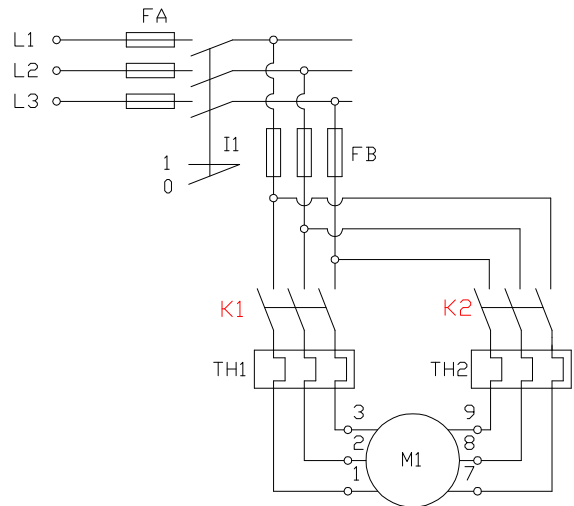

**Picture 5- C: connection diagrams to the three-phase network and time charts for the activation of contactors K1, K2 and K3 in the two compressor starting modes: star-delta and part-winding;
FA, FB: main fuses and compressor’s fuses
I1: main switch;
M1: electrical motor;
TH1, TH2: overload relay;**

The motor stator is secured to the compressor casing by using a screw and a key. Hence no special tools are required to replace the motor. The electrical motors are designed and tested in compliance with the European standard EN 60335-2-34.

5.2 Protection devices

5.2.1 Motor thermistors

To protect the motor against high temperatures six PTC thermistors connected in series are inserted in the motor windings. Three thermistors are positioned on the intake side of the motor (suction side) and have an activation temperature of 100°C, while the other three are positioned on the opposite side of the motor (discharge side) and have an activation temperature of 120°C.

The resistance of the chain of thermistors when cold (temperature less than 40°C) must be less than 1800 Ohm; but even if just one of the thermistors reaches the critical temperature, the resistance of the chain will increase exponentially, with the consequent activation of the INT 69 VS electronic module (INT 69 RCY as an option), which cut off the power supply to the motor. The resistance can be measured between terminals T1 and T2 on the terminal block.

	<p>Warning! When measuring the resistance of the thermistors' chain, never apply a voltage higher than 3V.</p>
---	---

5.2.2 INT 69 VS

This electronic protection module is supplied as standard with the compressor and in combination with the thermistors it carries out the function of monitoring the temperature of the electrical motor windings. The thermistors in the motor can be connected in series to a further PTC probe for monitoring the temperature of the oil (set point 120°C; picture 5-F shows the position of the temperature sensor in the compressor; see also chapter SA-11: “Additional cooling”).

The protection device is electrically connected by the manufacturer as shown in picture 5-D. For the technical specifications of the module, see Table A.

Activation threshold	12500 Ohm;
Reset threshold	2400 Ohm;
Power supply	230 V ±10%, 50/60 Hz, 3VA;
Switching relay	250 V AC, continuous current max 5 A, switch capacity 300 VA
Ambient temperature	-30° C...+60° C
Fuse required	4 A quick blow

TableA: INT 69 VS technical specifications;

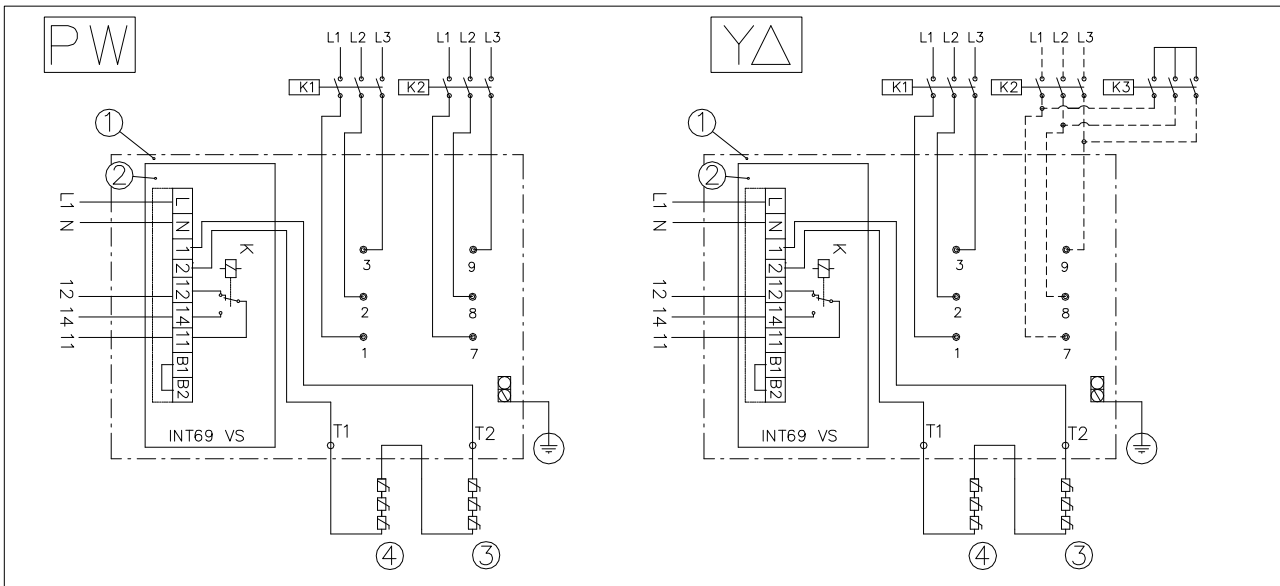

Picture 5-D: electrical connections to the INT 69 VS module (part-winding and star delta);

- | | |
|---------------------------------------|---|
| 1: Terminal plate; | L1/N: Phase + neutral; |
| 2: Motor protection device INT 69 VS; | 11/14: Control circuit; |
| 3, 4: Motor thermistors PTC; | 1/2 : Connection cables to thermistor (orange); |
| L1, L2, L3: Supply voltage; | 12: alarm; |
| PW: K1 Contactor 1st PW (PW 50%); | B1, B2: Link for automatic reset; |
| K2 Cont. 2nd PW (PW 50%); | K: Relay (supplied fitted); |
| Y/Δ: K1 and K3 Start contactors (Y); | |
| K1 and K2 Run contactors (Δ); | |

To protect the electronic module, it is recommended to install a 4A fast-blow fuse to prevent the contacts from melting in the event of short-circuits.

The correct operation of the module must be checked when testing the installation and after any fault occurred in the auxiliary circuit. For this purpose, remove one of the connection wires from terminals T1 and T2 on the terminal block (not powered). When supplying power to the auxiliary control circuit, the power runs between terminals 12 and N, signalling an alarm.

In the event where the thermal protector on the electric motor is activated, this must be reset by specialist personnel. The device can only be reset after the causes of activation have been identified and removed.

	<p>Warning!</p> <ul style="list-style-type: none"> ✓ Following an alarm and after the motor has cooled down, an internal lockout prevents the compressor from starting again. Reset the INT 69 VS module by briefly disconnecting the power supply through the main switch or by pressing a specific button that can be installed for this purpose in the power supply line. ✓ Never apply power to the module terminals 1-2, B1-B2, nor to terminals T1 and T2 of the terminal plate.
---	---

A phase monitor must be installed to check the correct direction of the electrical motor rotation.

5.2.3 INT 69 RCY

The INT 69 RCY module is available as an optional (standard for SRC-S-785/885/985). This module carries out the following functions:

- ✓ monitors the temperature of the electrical motor and the oil;
- ✓ monitors the direction of rotation of the motor;
- ✓ monitors for a missing phase;

The electrical connections on the INT 69 RCY protection module are shown in pictures 5-F (PW and Star/Delta). For the technical specifications of the module see Table B in the following pages.

Monitoring the temperature

The temperature of the motor and the oil are monitored by the PTC sensors. The oil temperature sensor is connected in series to the chain of thermistors in the electrical motor (for its position of the sensor on the compressor see picture 5-F). Manual reset of alarm through disconnection of power supply for at least 5 seconds .

The temperature is monitored through its value (static control) and through the swiftness of its increase (dynamic control).

Only when the alarm is given by the temperature static control, and only if the reset level has been reached, the motoprotector will perform an automatic reset after 5 minutes from the alarm detection.

TAKE NOTE: Before re-starting the compressor following an alarm, the operator must check the temperature of the motor and the oil temperature, making sure that the resistance of the PTC chain is less than 2,9 kΩ.

Monitoring the direction of rotation of the motor

The correct direction of rotation of the motor is monitored by measuring the sequence of the phases at the compressor terminals.

The function has a manual reset and requires the power supply to be disconnected for at least 5s . The check is performed in the first 5 seconds at each starting.

TAKE NOTE: Before re-starting the compressor check the correct sequence of the phases

Monitoring for a missing phase

The phases are monitored during the start-up and. The alarm causes the stop of compressor and it could not start before 5 minutes.

So the reset is automatic till maximum 10 consecutive restarts (in the first 24 hours of working) with a missing phase the compressor is stopped definitively. After this, it must be reset manually by disconnecting the power supply for at least 2 seconds.

TAKE NOTE: Before re-starting the compressor check the power supply of the compressor.

**SRC-S-113/133/163/183/213/
253/303/353/413/463/503/ 553/603**

SRC-S-255/285/305/755/785/885/985

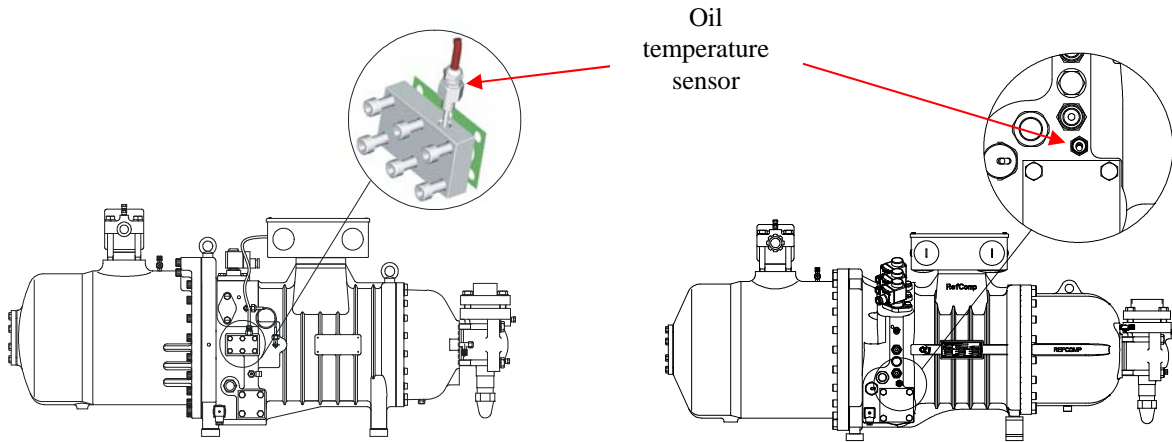

SRC-XS



Figura 5-E: position on compressor for oil temperature monitoring sensor ;



- 1) Terminal box
- 2) Motor protection device INT 69 RCY
- 3-4) Motor thermistors PTC
- R2) Discharge gas temperature sensor
- L1-L2-L3) Power supply
- PW motor: K1 PW contactor 50%
- K2 PW contactor 50%,
- Y/Dmotor: K1-K3 start contactors (Y)
- K1-K2 run contactors (D)
- L/N) Phase + neutral 230V-50/60Hz
- 6) Control circuit
- 1/2) Connection cables to thermistors
- 5) Relay
- 7) Led

Picture 5-F: electrical connections to the INT 69 RCY module (part-winding and star delta)

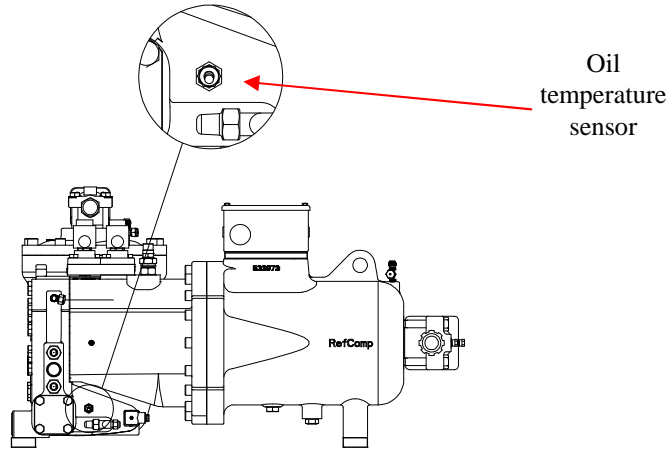
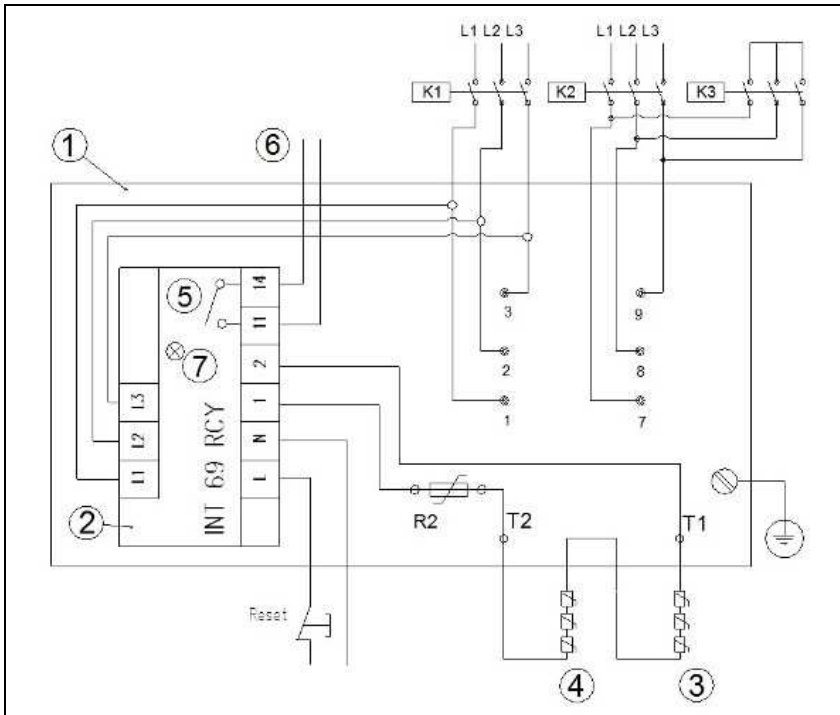
Trip value	11400 Ohm
Reset value	2900 Ohm
Power supply	115/120 V or 230/240 V -15/+10%, 50/60 Hz, Absorbed power : 3VA
Output relay	AC, 240 V, 2,5° max continuous current, C300 Potential-free normally open contact (NOC)
Ambient working conditions (temp.)	-30°C...+60°C
Required fuse	4 A, fast type
Motor supply	200...690V AC ±10%, 3 AC , 50/60 Hz

Table B: INT 69 RCY technical specifications;

The INT 69 RCY module is generally fitted in the compressor’s electrical box. However it can be moved and fitted in a main control box far away from the compressor according to the following indications:

- ✓ The connection cables to the motor terminals must be connected following the specified sequence: L1 to terminal 1, L2 to terminal 2 and L3 to terminal 3; **check the direction of rotation with an indicator**;
- ✓ To connect the module to the PTC sensors, only use shielded cables or a twisted pair (danger of induction);

Alarm signals

The motoprotector INT 69 RCY is equipped on its box with a led for displaying the kind of the alarm occurred. The kind of optic signalling identifies the motoprotector status and in case of alarm also its cause.

- ✓ Solid green LED: fault-free status
- ✓ Blinking red LED: alarm status

Through the cyclical sequence of the red blinks it is possible to identify both the category and the type of the detected alarm.

Specifically, with reference to the table and examples reported below, the blinking cycle can be divided onto two subsequent sequences: at first that of the alarm category and afterwards that of the alarm type.

- 1[^] cycle sequence (alarm category):

- ✓ 1 blink followed by a pause of 1 second identifies alarms caused by the electric motor temperature (PTC) or by the discharge temperature;
- ✓ 2 blinks followed by a pause of 1 second identify alarms caused by the electrical phases (Phase Monitoring).

- 2[^] cycle sequence (alarm type, in succession to the first sequence):

A certain number of blinks according to the alarm type (look at the following table), followed by a pause of 2,5 seconds.

Error Category		Fault Type	
Number of Flash	Error Category	Number of Flash	Fault Type
1	PTC	1	Static
		2	Dynamic
		3	Time delay active (PTC < Restart Limit)
2	Phase Monitoring	1	False phase sequence
		2	Phase failure

For your convenience hereby we report a couple of examples:

1. “PTC” alarm caused by a too fast increase of the motor temperature.

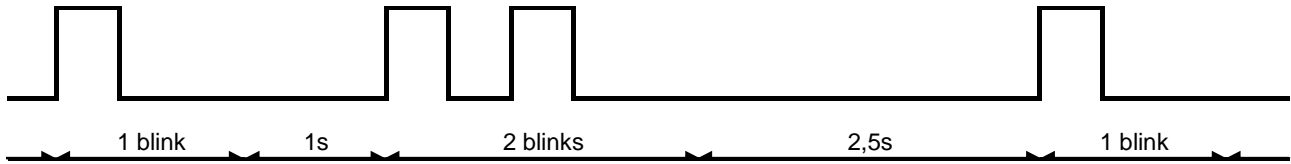

2. “Monitoring Phase” alarm caused by wrong phase sequence.

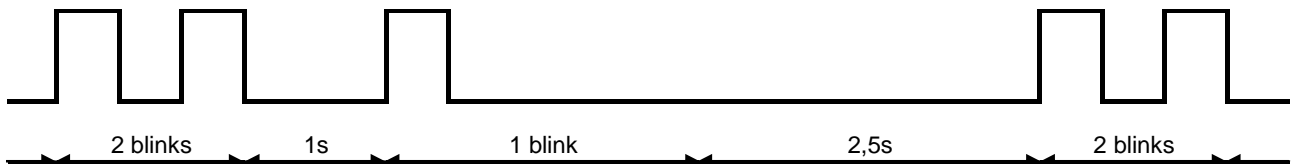

5.3 Power supply

	<p>Warning!</p> <p> For the direction of rotation of the rotors see chapter SA-01: “General”. If the motor turns in the opposite direction the compressor can be seriously damaged.</p>
--	--

- Motor power supply for standard version (part-winding and star-delta):
400 V - 3 phases - 50 Hz / 460 V - 3 phases - 60 Hz (other power supply on request);
- Permissible voltage range: ± 10 % of rated voltage;
- Permissible voltage unbalance between L1 - L2 - L3: ± 2 %;
- Maximum voltage drop during the starting phase: 10 % of rated voltage;
- Permissible frequency range: ± 2 % of rated frequency;
- Permissible current unbalance: 5 /12 % calculated as follows:

Currents on the first contactor: $I_1 - I_2 - I_3$

Currents on the second contactor: $I_7 - I_8 - I_9$

Currents of each supply phase

$$I_R = I_1 + I_7$$

$$I_S = I_2 + I_8$$

$$I_T = I_3 + I_9$$

Unbalance of the three R - S - T currents:

$$I_M = \frac{I_R + I_S + I_T}{3}$$

$$SB_3^{\%} = \frac{\text{MAX}(I_R, I_S, I_T) - I_M}{I_M} \cdot 100$$

$$SB_3^{\%} < 5\%$$

Unbalance of the six 1 - 2 - 3 - 7 - 8 - 9 currents:

$$I_M = \frac{I_1 + I_2 + I_3 + I_7 + I_8 + I_9}{6}$$

$$SB_6^{\%} = \frac{\text{MAX}(I_1, I_2, I_3, I_7, I_8, I_9) - I_M}{I_M} \cdot 100$$

$$SB_6^{\%} < 12\%$$

5.4 Selection of electrical components

The various electrical components: cables, fuses etc. must be sized considering the maximum current that can be absorbed by the electrical motor during normal operation, i.e. the FLA.

Specifically, erring on the side of safety, in Part-Winding configuration the contacts on the motor contactors must be sized for a current equal to at least 65% of the maximum operating current (FLA). On the other hand, for the star-delta configuration the contacts must be sized for a current equal to at least 75% of the FLA.

5.5 Size of the motor

The electric motors are available in two sizes:

- ✓ Full size (motor 1): for the refrigerants R22, R407C, R134a, R404A e R507 (see chapter SA-10 “*Operating limits*”);
- ✓ Size small (motor 2): for R134a refrigerant only (see chapter SA-10 “*Operating limits*”); Normal operating conditions with a high level of condensation require a full size motor (motor 1);

5.6 Technical data

Mod. SRC-S		113	133	163	183	213	255	285	305	353	413	463	503	553	603	785	885	985		
Mod. SRC-XS		40	50	60																
Nominal motor power Potenza nominale motore	HP/kW*	40/30 (30/22)	50/37 (40/30)	60/45 (50/37)	70/52 (60/45)	80/60 (70/52)	100/75 (80/60)	110/82 (90/67)	120/90 (100/75)	140/105 (120/90)	160/120 (140/105)	180/135 (160/120)	200/150 (180/135)	220/164 (200/150)	240/179 (220/164)	300 / 224 (240 / 179)	350 / 261 (270 / 201)	390 / 291 (300 / 224)		
Motor - Motore 1 (full size)																				
Nominal Voltage (V) Voltaggio Nominale (V)	V	400/3/50Hz - 460/3/60Hz																		
PW	Starting current (A) Corrente di avviamento (A)	LRA Y	277	303	373	280	351	495	586	646	-	-	-	-	-	-	-	-	-	
		LRA YY	398	406	547	459	580	770	965	770	-	-	-	-	-	-	-	-	-	-
	Max running current (A) Massima corrente di funzionamento (A)	FLA	80	90	96	124	140	168	192	196	-	-	-	-	-	-	-	-	-	-
Y / Δ	Starting current (A) Corrente di avviamento (A)	LRA Y	131	134	182	159	193	254	322	318	354	374	453	543	595	595	876	1062	1062	
		LRA Δ	398	406	547	459	580	770	965	953	1155	1155	1333	1645	1802	1802	2627	3186	3186	
	Max running current (A) Massima corrente di funzionamento (A)	FLA	80	90	96	124	140	168	192	196	225	245	270	300	334	400	545	600	650	
Motor - Motore 2 (small size): only for R134a / solo per R134a																				
PW	Starting current (A) Corrente di avviamento (A)	LRA Y	277	277	303	262	280	351	351	495	-	-	-	-	-	-	-	-	-	
		LRA YY	331	398	406	422	459	580	580	770	-	-	-	-	-	-	-	-	-	-
	Max running current (A) Massima corrente di funzionamento (A)	FLA	50	62	68	79	96	105	117	130	-	-	-	-	-	-	-	-	-	-
Y / Δ	Starting current (A) Corrente di avviamento (A)	LRA Y	109	131	134	139	159	193	193	254	276	354	374	453	543	543	783	876	1062	
		LRA Δ	331	398	406	422	459	580	580	770	876	1155	1155	1333	1645	1645	2348	2627	3186	
	Max running current (A) Massima corrente di funzionamento (A)	FLA	50	62	68	79	96	105	117	130	156	168	185	205	229	267	400	435	490	

Standard Delivery -
Fornitura standard

Table C: electrical data of the compressors;

SRC-XS and SRC-S Compressor series
Model designation & technical data
(SA-06-09-E)

6. MODEL DESIGNATION & TECHNICAL DATA	2
6.1 MODEL DESIGNATION	2
6.2 TECHNICAL DATA	3

6. Model designation & technical data

6.1 Model designation

SRC-S-253 L4

- 1) **SRC-S-253 L4** = Semi-hermetic refrigerant compressor;

- 2) SRC-**S**-253 L4 = Series:
S = models: 113/133/163/183/213/253/255/285/303/305/353/413/463/503/553/603/755/785/885/985;
XS = models: 40/50/60;

- 3) SRC-S-**253** L4:
Series S: given cooling capacity [kW] at 2°C evaporating temperature, 40°C condensing temperature, R22 refrigerant and f = 50 Hz supply frequency;
Series XS: nominal motor power [HP];

- 4) SRC-S-253 **L4**:
L = Electrical accessories 220V AC 50/60Hz;
M = Electrical accessories 110V AC 50/60Hz;
Y = Electrical accessories 24V AC 50/60Hz;
U = Electrical accessories UL approved 220V AC 50/60Hz (only for S series);
V = Electrical accessories UL approved 110V AC 50/60Hz (only for S series);

- 5) SRC-S-253 **L4**:
2 = 3 steps capacity control (100-75-50 %) made with two solenoid valves, only for XS series;
4 = 4 steps capacity control (100-75-50% - minimum step) made with 3 solenoid valves, only for S series;
Z = Infinite capacity control (from minimum capacity to 100% or from 50 to 100%), only for S series;

Model designation & technical data



6.2 Technical data

Mod. SRC-S		113	133	163	183	213	255	285	305	353	413	463	503	553	603	755	785	885	985	
Mod. SRC-XS		40	50	60																
Nominal motor power Potenza nominale motore	HP/kW*	40/30 (30/22)	50/37 (40/30)	60/45 (50/37)	70/52 (60/45)	80/60 (70/52)	100/75 (80/60)	110/82 90/67	120/90 (100/75)	140/105 (120/90)	160/120 (140/105)	180/135 (160/120)	200/150 (180/135)	220/164 (200/150)	240/179 (220/164)	240/179 (220/164)	300 / 224 (240 / 179)	350 / 261 (270 / 201)	390 / 291 (300 / 224)	
Displacement at 50/60 Hz Volume Spostato a 50/60 Hz	m3/hr	118/ 142	150/ 180	175/ 210	205/ 246	237/ 284	286/ 343	318/ 382	341/409	402/482	445/534	510/612	562/674	600/720	700/840	860/1032	910 /1092	1000 /1200	1100 /1320	
Weight Peso	Kg	325 / 310**	330 / 305**	335 / 310**	510	515	585	590	595	730	740	775	1070	1090	1020	1020	1300	1300	1300	
Oil charge Carica olio	dm3	6 / 6,5	6 / 6,5	6 / 6,5	7	7	10	10	10	14	14	16	19	19	20	23	25	25	25	
Crankcase heater Resistenza carter		230V-200W-50/60Hz									230V-275W-50/60Hz									
Discharge line, internal Ø Raccordo mandata, Ø interno	mm/ inches	42 / 1 5/8"	42 / 1 5/8"	42 / 1 5/8"	54 / 2 1/8"	54 / 2 1/8"	54 / 2 1/8"	54 / 2 1/8"	54 / 2 1/8"	80 / 3 1/8"	80 / 3 1/8"	80 / 3 1/8"	80 / 3 1/8"	80 / 3 1/8"	80 / 3 1/8"	80 / 3 1/8"	104,8 / 4 1/8"	104,8 / 4 1/8"	104,8 / 4 1/8"	
Suction line, internal Ø Raccordo aspirazione, Ø interno	mm/ inches	54 / 2 1/8"	54 / 2 1/8"	54 / 2 1/8"	67 / 2 1/8"	67 / 2 1/8"	80 / 3 1/8"	80 / 3 1/8"	80 / 3 1/8"	92 / 3 5/8"	92 / 3 5/8"	92 / 3 5/8"	104,8 / 4 1/8"	104,8 / 4 1/8"	104,8 / 4 1/8"	104,8 / 4 1/8"	133 / 5 1/4"	133 / 5 1/4"	133 / 5 1/4"	
Capacity control steps Controllo di capacità		For XS: STEP: 100,75,50									For SRC-S: STEP: 100,75,50%, minimum capacity; STEPLESS: from minimum capacity to 100% or from 50 to 100% - on demand									
Protection devices Dispositivi di protezione		INT 69 VS (Standard) INT 69 RCY (Optional)															INT 69 RCY (Optional)			
Lubricant Lubrificante		R22: CPI CP 4214 320 (for SRC-S, on request, SUNISO 4GS) R407C - R134a - R404A - R507: FUCHS Reniso Triton SE 170 (on request: CASTROL SW 220 HT-EU or CPI Solest 170)																		

- Data between brackets refer to compressor with motor 2 (small size) / I dati tra parentesi fanno riferimento a compressori con motori di taglia ridotta
- ** Data riferiti ai modelli XS

SRC-XS and SRC-S series compressors

Extent of delivery

(SA-07-04-E)

7. EXTENT OF DELIVERY

2

7. Extent of delivery

The standard delivery includes:

- ✓ Mineral oil charge for refrigerant HCFC: R22;
- ✓ Compressor with $V_i = 2,6$ built-in volumetric ratio;
- ✓ Suction side solder connection;
- ✓ Discharge shut off valve;
- ✓ Integrated check valve;
- ✓ Integrated safety relief valve;
- ✓ Flanged –on oil separator;
- ✓ Oil sight glass;
- ✓ Oil filter;
- ✓ Steps or stepless capacity control (the SRC-XS series is available only with the step configuration);
- ✓ Electronic module INT 69 RCY (for SRC-S-785/885/985)
- ✓ 6 thermistors integrated into the motor windings and electronic module INT 69 VS for motor temperature monitoring;
- ✓ Electrical box with protection class IP54;
- ✓ 400 V \pm 10% - 3 - 50 Hz / 460 V \pm 10% - 3 - 60 Hz motor (for start up mode see chapter SA-05: “*Electrical devices*”);
- ✓ Electrical devices 230 V- 1 - 50/60 Hz;
- ✓ Nitrogen protective charge;
- ✓ Rubber vibration dampers kit.

Available on demand:

- ✓ Electrical motors with special voltage;
- ✓ Only for the SRC-S series: compressor with $V_i = 3.2$ built-in volumetric ratio;
- ✓ Crankcase heater;
- ✓ Electrical accessories with voltages different than the standard;
- ✓ Poliolester oils (POE) for the refrigerants HFC: R134a, R407C, R404A e R507;
- ✓ Electronic module INT 69 RCY (motor and oil temperature monitoring, motor rotation direction monitoring, phase failure monitoring);
- ✓ Suction shut off valve;
- ✓ Liquid injection connection;
- ✓ ECO connection with shut-off valve;
- ✓ kit for the connections to the external oil circuit (models SRC-XS-40/50/60 and SRC-S-255/285/305/785/885/985 are already fitted with these connections);
- ✓ Bridges for direct starting (D.O.L.);
- ✓ Oil flow switch kit;
- ✓ Conversion kit for infinity/step capacity control, only for compressor series SRC-S.

SRC-XS and SRC-S series compressors
Dimensional drawings and packaging
(SA-08-05-E)

8.	DIMENSIONAL DRAWINGS AND PACKAGING	2
8.1	DIMENSIONAL DRAWINGS	2
8.2	PACKAGING	12

8. Dimensional drawings and packaging

8.1 Dimensional drawings

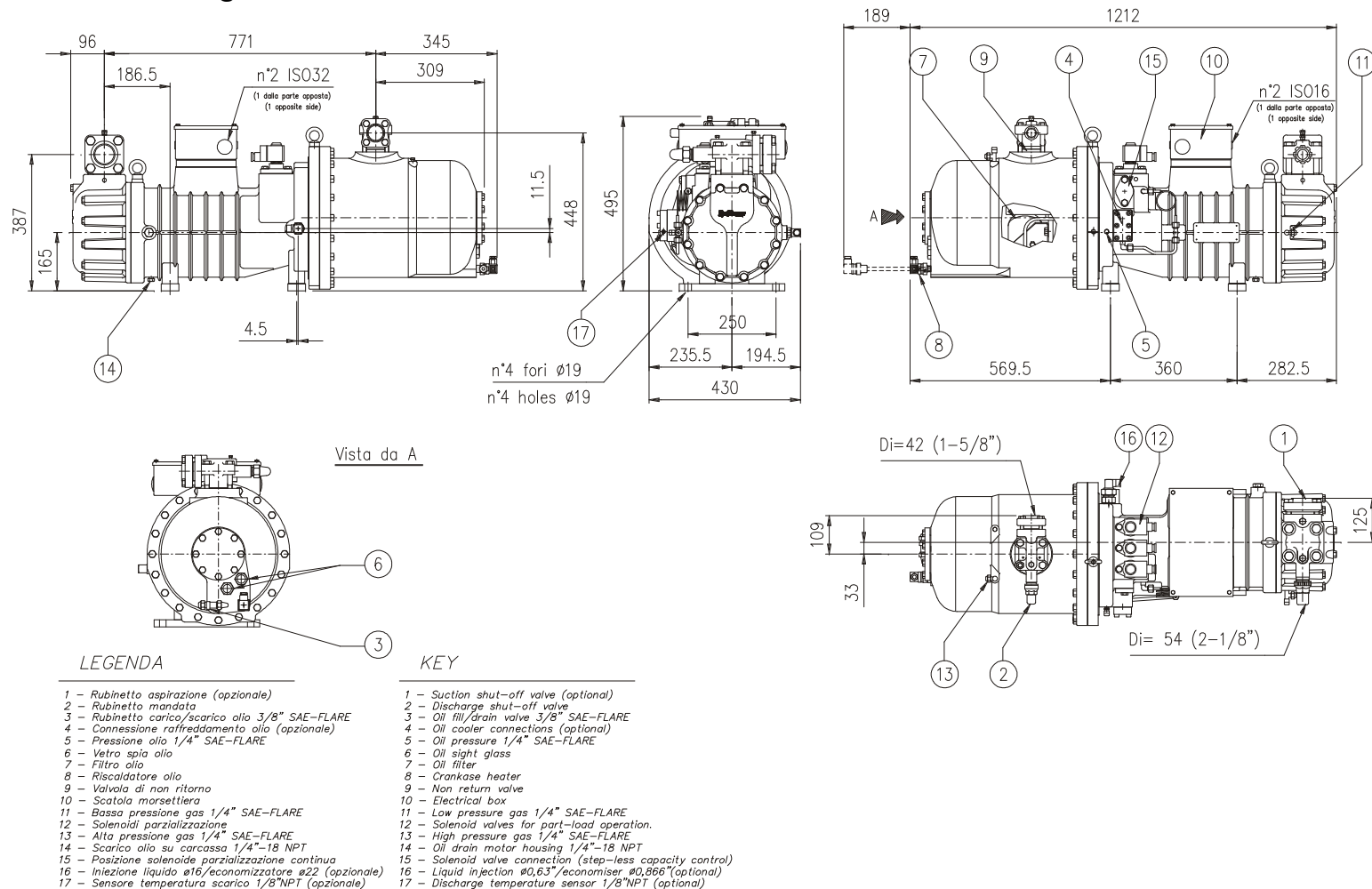

Picture 8-A: dimensional drawing of the models: SRC-S-113/133/163 (drawing code: MSI007 r.05);

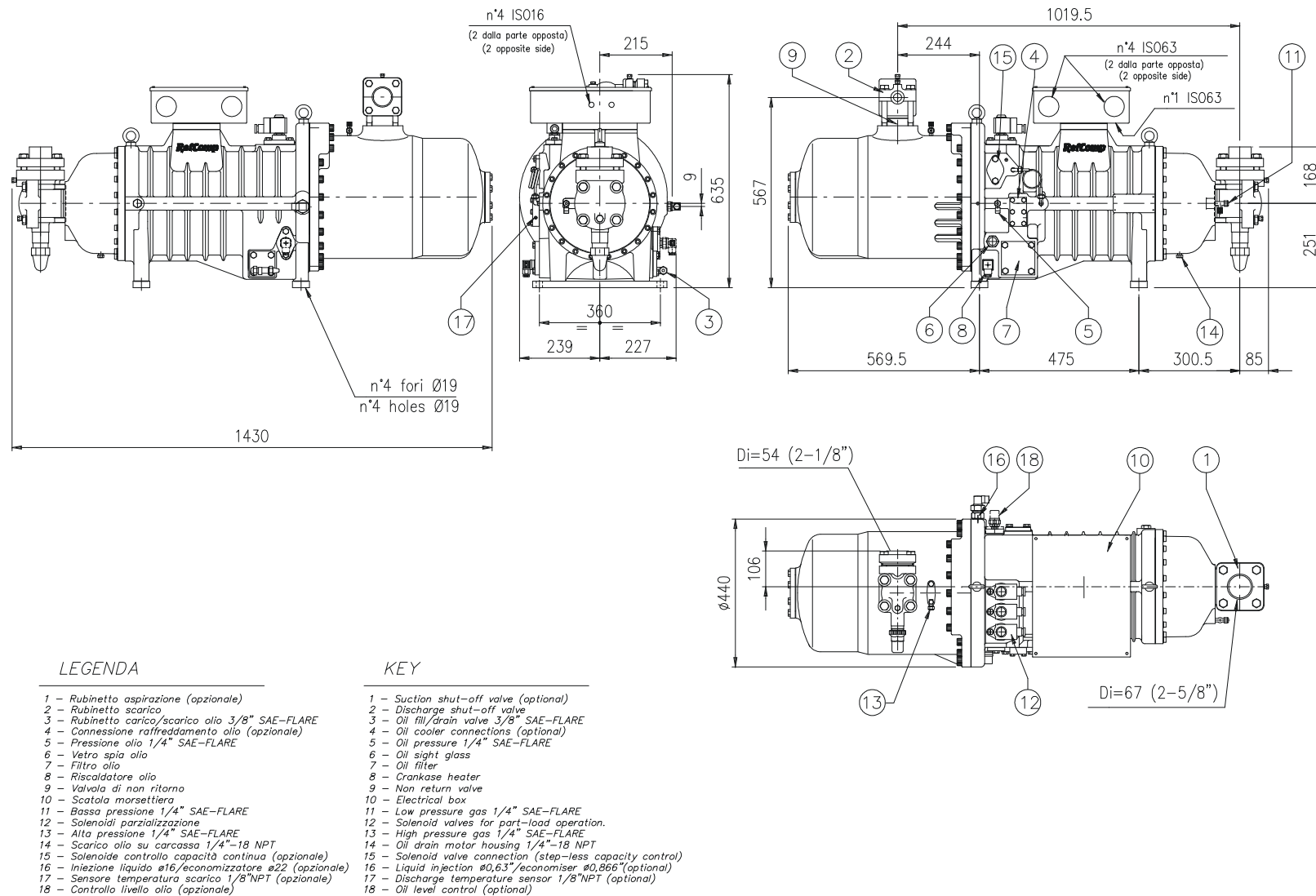

Picture 8-B: dimensional drawing of the models: SRC-S-183/213 (drawing code: MSI014 r.05);

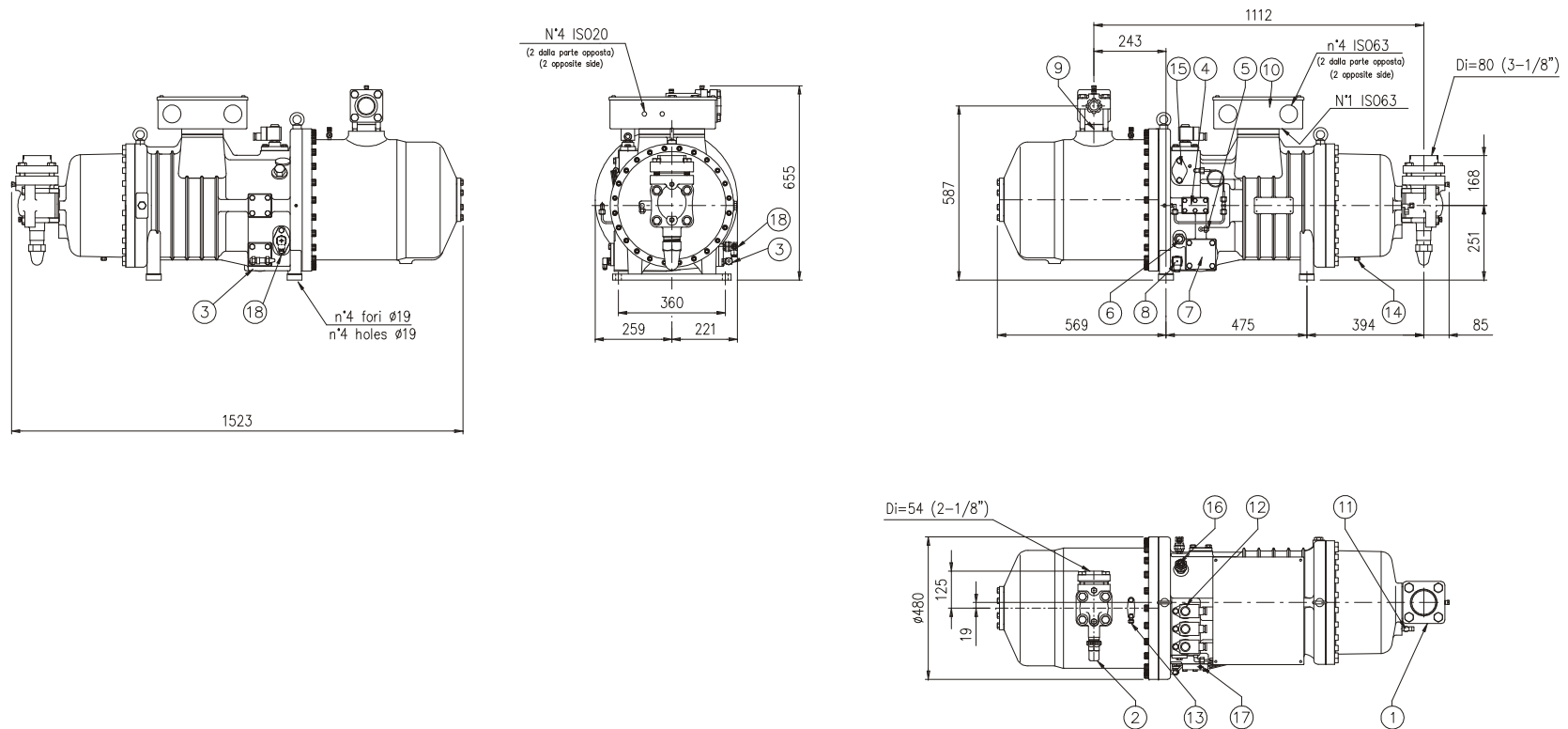

LEGENDA

- 1 - Rubinetto aspirazione (opzionale)
- 2 - Rubinetto mandata
- 3 - Rubinetto carico/scarico olio 3/8" SAE-FLARE
- 4 - Connessione raffreddamento olio (opzionale)
- 5 - Pressione olio 1/4" SAE-FLARE
- 6 - Vetro spia olio
- 7 - Filtro olio
- 8 - Riscaldatore olio
- 9 - Valvola di non ritorno
- 10 - Scatola morsettiere
- 11 - Bassa pressione gas 1/4" SAE-FLARE
- 12 - Solenoidi parzializzazione
- 13 - Alta pressione gas 1/4" SAE-FLARE
- 14 - Scarico olio su carcassa 1/4"-18 NPT
- 15 - Posizione solenoide parzializzazione continua
- 16 - Iniezione liquido ø16/economizzatore ø22 (opzionale)
- 17 - Sensore temperatura scarico 1/8"NPT (opzionale)
- 18 - Controllo livello olio (opzionale)

KEY

- 1 - Suction shut-off valve (optional)
- 2 - Discharge shut-off valve
- 3 - Oil fill/drain valve 3/8" SAE-FLARE
- 4 - Oil cooler connections (optional)
- 5 - Oil pressure 1/4" SAE-FLARE
- 6 - Oil sight glass
- 7 - Oil filter
- 8 - Crankcase heater
- 9 - Non return valve
- 10 - Electrical box
- 11 - Low pressure gas 1/4" SAE-FLARE
- 12 - Solenoid valves for part-load operation.
- 13 - High pressure gas 1/4" SAE-FLARE
- 14 - Oil drain motor housing 1/4"-18 NPT
- 15 - Solenoid valve connection (step-less capacity control)
- 16 - Liquid injection ø0,63"/economiser ø0,866" (optional)
- 17 - Discharge temperature sensor 1/8"NPT (optional)
- 18 - Oil level control (optional)

Picture 8-C: dimensional drawing of the models: SRC-S-253/303 (drawing code: MSI015 r.04);

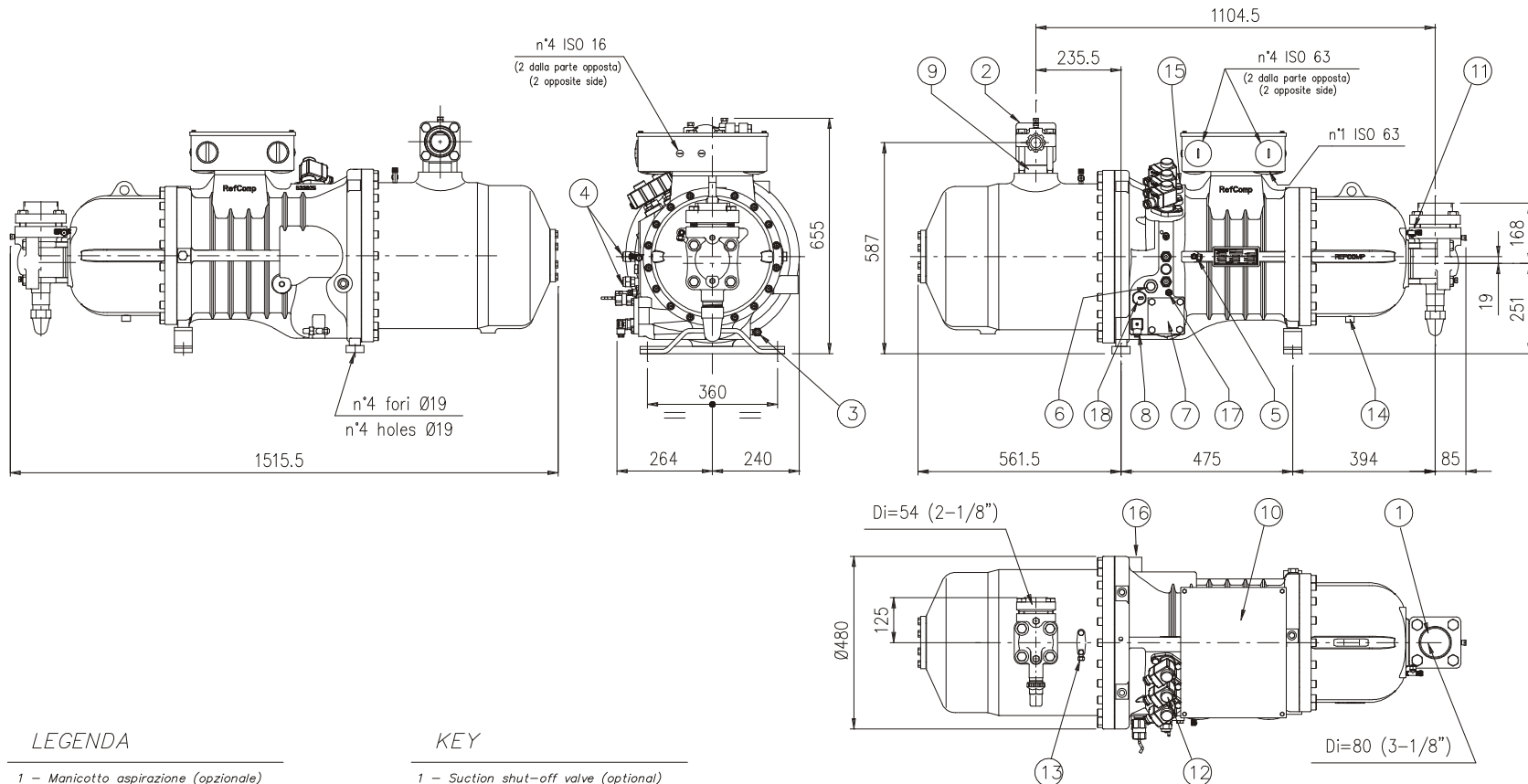

LEGENDA

- 1 - Manicotto aspirazione (opzionale)
- 2 - Rubinetto scarico
- 3 - Rubinetto carico/scarico olio 3/8" SAE-FLARE
- 4 - Connessione raffreddamento olio
- 5 - Pressione olio 1/4" SAE-FLARE
- 6 - Vetro spia olio
- 7 - Filtro olio
- 8 - Riscaldatore olio
- 9 - Valvola di non ritorno
- 10 - Scatola morsettiere
- 11 - Bassa pressione 1/4" SAE-FLARE
- 12 - Solenoidi parzializzazione
- 13 - Alta pressione 1/4" SAE-FLARE
- 14 - Scarico olio
- 15 - Solenoide controllo capacità continua (opzionale)
- 16 - Iniezione liquido Ø16/economizzatore Ø22 (opzionale)
- 17 - Sensore temperatura scarico 1/8"NPT (opzionale)
- 18 - Controllo livello olio (opzionale)

KEY

- 1 - Suction shut-off valve (optional)
- 2 - Discharge shut-off valve
- 3 - Oil fill/drain valve 3/8" SAE-FLARE
- 4 - Oil cooler connections
- 5 - Oil pressure 1/4" SAE-FLARE
- 6 - Oil sight glass
- 7 - Oil filter
- 8 - Crankcase heater
- 9 - Non return valve
- 10 - Electrical box
- 11 - Low pressure gas 1/4" SAE-FLARE
- 12 - Solenoid valves for part-load operation.
- 13 - High pressure gas 1/4" SAE-FLARE
- 14 - Oil drain
- 15 - Solenoid valve connection (step-less capacity control)
- 16 - Liquid injection Ø0,63"/economiser Ø0,866"(optional)
- 17 - Discharge temperature sensor 1/8"NPT (optional)
- 18 - Oil level control (optional)

Picture 8-D: dimensional drawing of the models: SRC-S-255/285/305 (drawing code: MSI037 r.02);

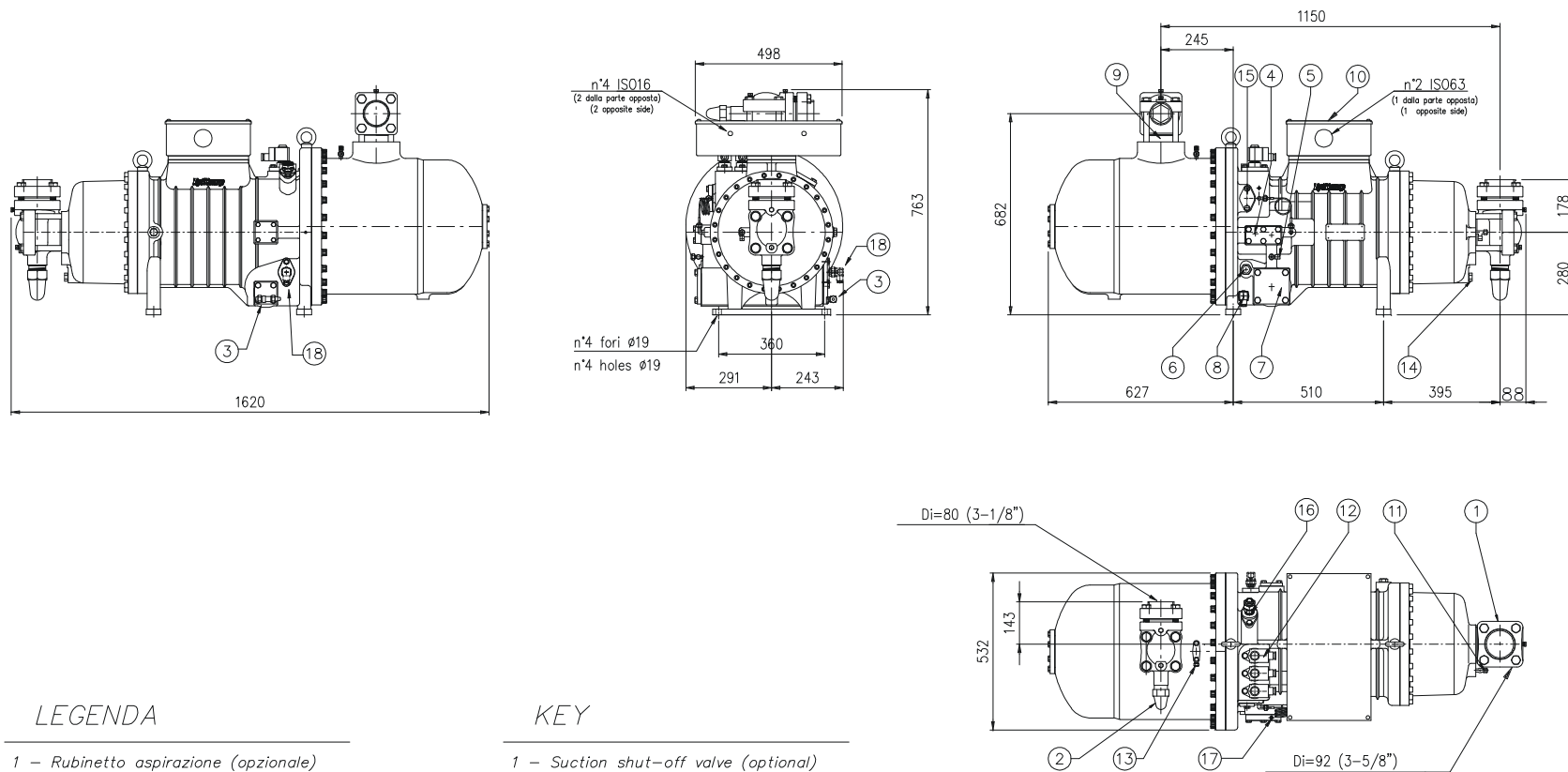

LEGENDA

- 1 - Rubinetto aspirazione (opzionale)
- 2 - Rubinetto mandata
- 3 - Rubinetto carico/scarico olio 3/8" SAE-FLARE
- 4 - Connessione raffreddamento olio (opzionale)
- 5 - Pressione olio 1/4" SAE-FLARE
- 6 - Vetro spia olio
- 7 - Filtro olio
- 8 - Riscaldatore olio
- 9 - Valvola di non ritorno
- 10 - Scatola morsettieria
- 11 - Bassa pressione gas 1/4" SAE-FLARE
- 12 - Solenoidi parzializzazione
- 13 - Alta pressione gas 1/4" SAE-FLARE
- 14 - Scarico olio su carcassa M16
- 15 - Posizione solenoide parzializzazione continua
- 16 - Iniezione liquido $\varnothing 22$ /economizzatore $\varnothing 28$ (opzionale)
- 17 - Sensore temperatura scarico 1/8"NPT (opzionale)
- 18 - Controllo livello olio (opzionale)

KEY

- 1 - Suction shut-off valve (optional)
- 2 - Discharge shut-off valve
- 3 - Oil fill/drain valve 3/8" SAE-FLARE
- 4 - Oil cooler connections (optional)
- 5 - Oil pressure 1/4" SAE-FLARE
- 6 - Oil sight glass
- 7 - Oil filter
- 8 - Crankcase heater
- 9 - Non return valve
- 10 - Electrical box
- 11 - Low pressure gas 1/4" SAE-FLARE
- 12 - Solenoid valves for part-load operation.
- 13 - High pressure gas 1/4" SAE-FLARE
- 14 - Oil drain motor housing M16
- 15 - Solenoid valve connection (step-less capacity control)
- 16 - Liquid injection $\varnothing 0,866$ /economiser $\varnothing 1,102$ (optional)
- 17 - Discharge temperature sensor 1/8"NPT (optional)
- 18 - Oil level control (optional)

Picture 8-E: dimensional drawing of the models: SRC-S-353/413/463 (drawing code: MSI001 r.10);

Dimensional drawings and packaging

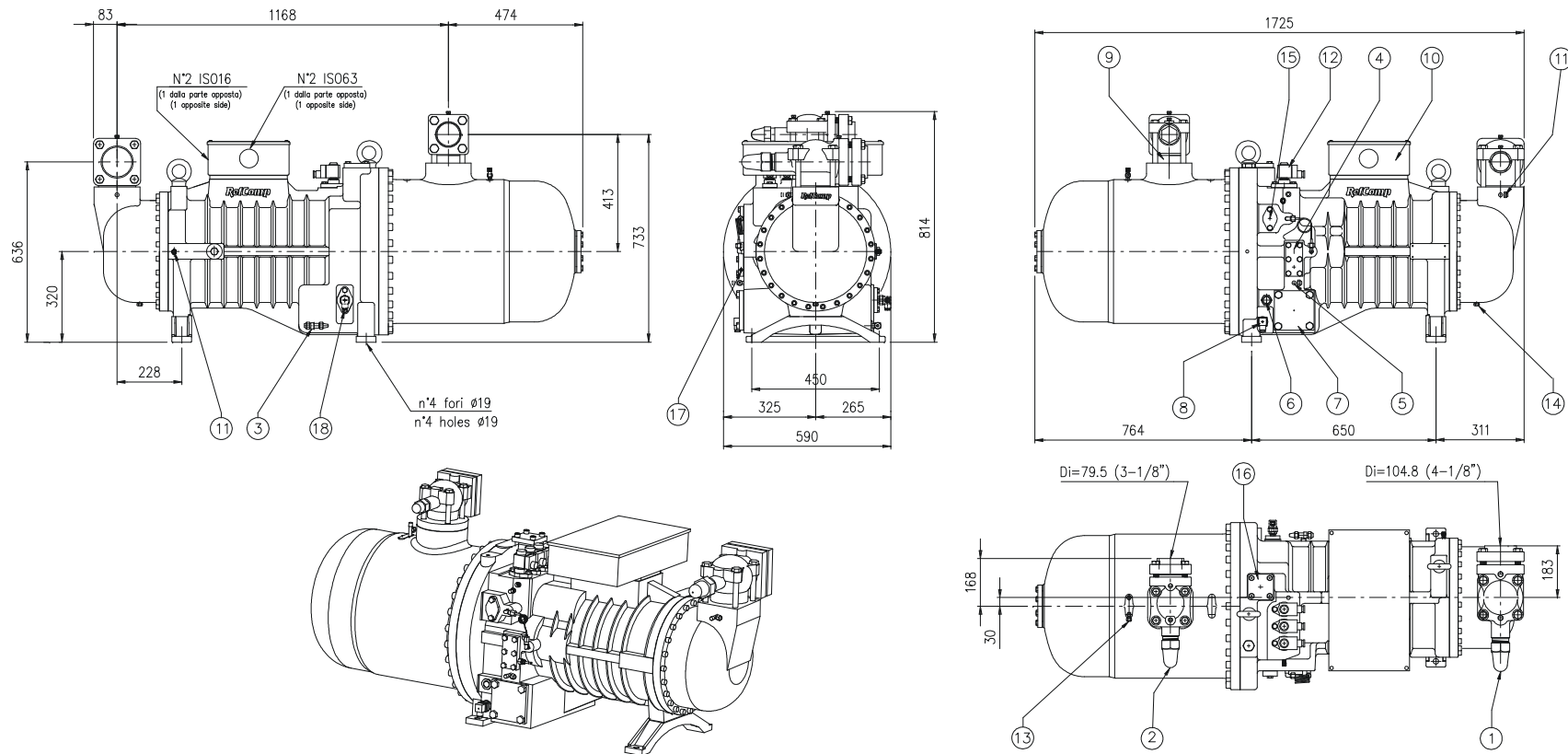

LEGENDA

- 1 - Rubinetto aspirazione (opzionale)
- 2 - Rubinetto mandata
- 3 - Rubinetto carico/scarico olio 3/8" SAE-FLARE
- 4 - Connessione raffreddamento olio (opzionale)
- 5 - Pressione olio 1/4" SAE-FLARE
- 6 - Vetro spia olio
- 7 - Filtro olio
- 8 - Riscaldatore olio
- 9 - Valvola di non ritorno
- 10 - Scatola morsetteria
- 11 - Bassa pressione 1/4" SAE-FLARE
- 12 - Solenoidi parzializzazione
- 13 - Alta pressione 1/4" SAE-FLARE
- 14 - Scarico olio su carcassa 1/4"-18 NPT
- 15 - Posizione solenoide parzializzazione continua
- 16 - Iniezione liquido ø42/economizzatore ø42 (opzionale)
- 17 - Sensore temperatura scarico 1/8"NPT (opzionale)
- 18 - Controllo livello olio (opzionale)

KEY

- 1 - Suction shut-off valve (optional)
- 2 - Discharge shut-off valve
- 3 - Oil fill/drain valve 3/8" SAE-FLARE
- 4 - Oil cooler connections (optional)
- 5 - Oil pressure 1/4" SAE-FLARE
- 6 - Oil sight glass
- 7 - Oil filter
- 8 - Crankcase heater
- 9 - Non return valve
- 10 - Electrical box
- 11 - Low pressure gas 1/4" SAE-FLARE
- 12 - Solenoid valves for part-load operation
- 13 - High pressure gas 1/4" SAE-FLARE
- 14 - Oil drain motor housing 1/4"-18 NPT
- 15 - Solenoid valve connection (step-less capacity control)
- 16 - Liquid injection ø1,653"/economiser ø1,653"(optional)
- 17 - Discharge temperature sensor 1/8"NPT (optional)
- 18 - Oil level control (optional)

Picture 8-F: dimensional drawing of the models: SRC-S-503/553/603 (drawing code: MSI025 r.05);

Dimensional drawings and packaging

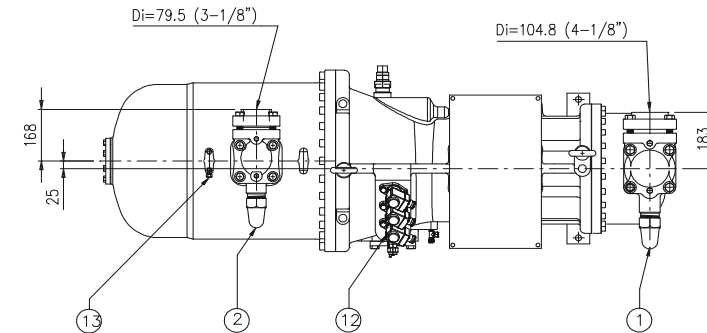
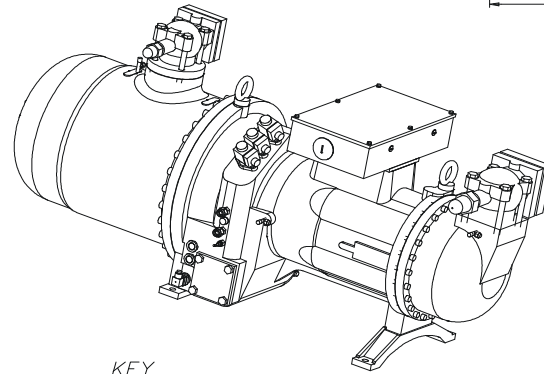
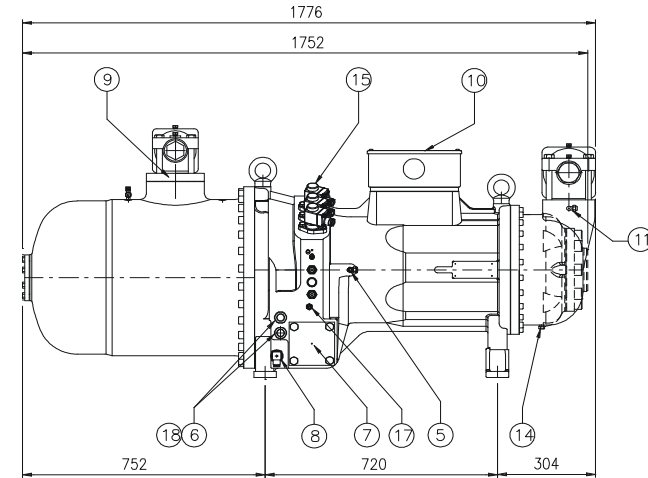
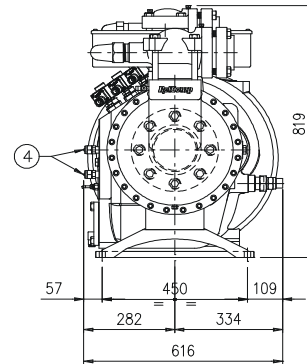
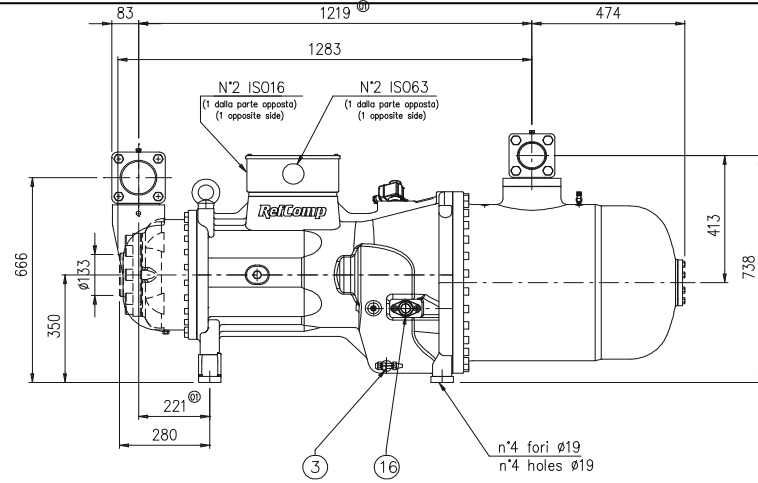

LEGENDA

- 1 - Rubinetto aspirazione (opzionale)
- 2 - Rubinetto mandata
- 3 - Rubinetto carico/scarico olio 3/8" SAE-FLARE
- 4 - Connessione raffreddamento olio
- 5 - Pressione olio 1/4" SAE-FLARE
- 6 - Vetro spia olio
- 7 - Filtro olio
- 8 - Riscaldatore olio
- 9 - Valvola di non ritorno
- 10 - Scatola morsettiere
- 11 - Bassa pressione 1/4" SAE-FLARE
- 12 - Solenoidi parzializzazione
- 13 - Alta pressione 1/4" SAE-FLARE
- 14 - Scarico olio su carcassa 1/4"-18 NPT
- 15 - Posizione solenoide parzializzazione continua
- 16 - Iniezione liquido ø28/economizzatore ø28
- 17 - Sensore temperatura scarico 1/8"NPT (opzionale)
- 18 - Controllo livello olio (opzionale)

KEY

- 1 - Suction shut-off valve (optional)
- 2 - Discharge shut-off valve
- 3 - Oil fill/drain valve 3/8" SAE-FLARE
- 4 - Oil cooler connections
- 5 - Oil pressure 1/4" SAE-FLARE
- 6 - Oil sight glass
- 7 - Oil filter
- 8 - Crankcase heater
- 9 - Non return valve
- 10 - Electrical box
- 11 - Low pressure gas 1/4" SAE-FLARE
- 12 - Solenoid valves for part-load operation
- 13 - High pressure gas 1/4" SAE-FLARE
- 14 - Oil drain motor housing 1/4"-18 NPT
- 15 - Solenoid valve connection (step-less capacity control)
- 16 - Liquid injection ø1"1/8"/economiser ø1"1/8"(optional)
- 17 - Discharge temperature sensor 1/8"NPT (optional)
- 18 - Oil level control (optional)

Figura 8-G: dimensioni SRC-S-755 (MSI080 r.00);

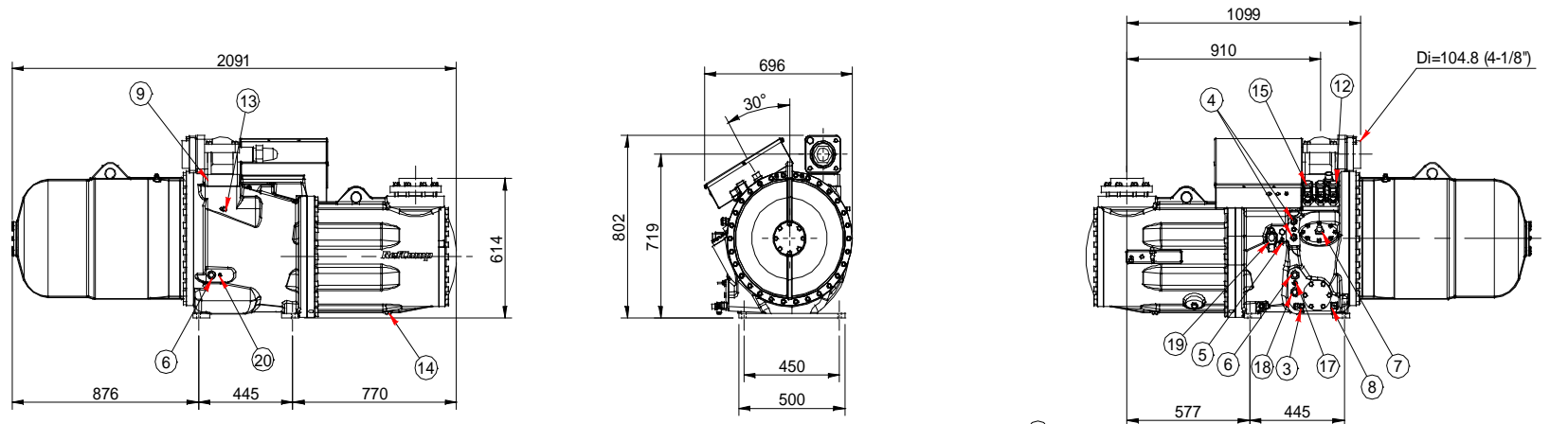

LEGENDA

- 1 - Manicotto aspirazione
- 2 - Rubinetto scarico
- 3 - Rubinetto carico/scarico olio 3/8" SAE-FLARE
- 4 - Connessione raffreddamento olio
- 5 - Pressione olio 1/4" SAE-FLARE
- 6 - Vetro spia olio
- 7 - Filtro olio
- 8 - Riscaldatore olio
- 9 - Valvola di non ritorno
- 10 - Scatola morsetti
- 11 - Bassa pressione 1/4" SAE-FLARE
- 12 - Solenoidi parzializzazione
- 13 - Alta pressione 1/4" SAE-FLARE
- 14 - Scarico olio su coperchio
- 15 - Solenoide controllo capacità (continua opzionale)
- 16 - Raccordo iniezione liquido Ø28/Rubinetto eco Ø42 (opzionale)
- 17 - Sensore temperatura scarico 1/8" NPT (opzionale)
- 18 - Controllo livello olio (opzionale)
- 19 - Solenoide controllo Vi (opzionale)
- 20 - Linea recupero olio 1/4" SAE-FLARE

KEY

- 1 - Suction connection
- 2 - Discharge shut-off valve
- 3 - Oil fill/drain valve 3/8" SAE-FLARE
- 4 - Oil cooler connections
- 5 - Oil pressure 1/4" SAE-FLARE
- 6 - Oil sight glass
- 7 - Oil filter
- 8 - Crankcase heater
- 9 - Non return valve
- 10 - Electrical box
- 11 - Low pressure gas 1/4" SAE-FLARE
- 12 - Solenoid valves for part-load operation.
- 13 - High pressure gas 1/4" SAE-FLARE
- 14 - Oil drain motor housing
- 15 - Solenoid valve connection (step-less capacity control)
- 16 - Liquid injection connection Ø28/ Economizer shut-off valve Ø42 (optional)
- 17 - Discharge temperature sensor 1/8" NPT (optional)
- 18 - Oil level control (optional)
- 19 - Vi control solenoid valve (optional)
- 20 - Oil recovery line 1/4" SAE-FLARE



Figura 8-H: Dimensioni per SRC-S-785/885/985 (MSI061 r.03)

Dimensional drawings and packaging

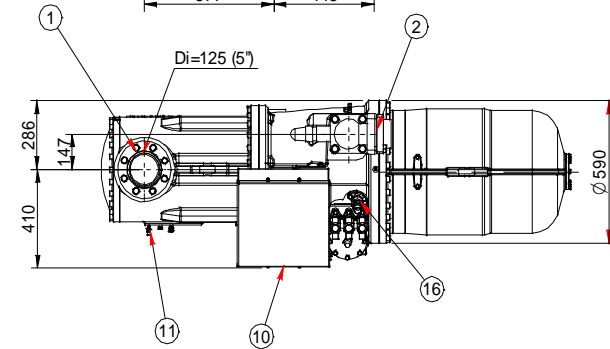
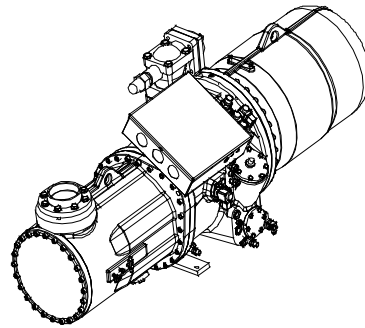
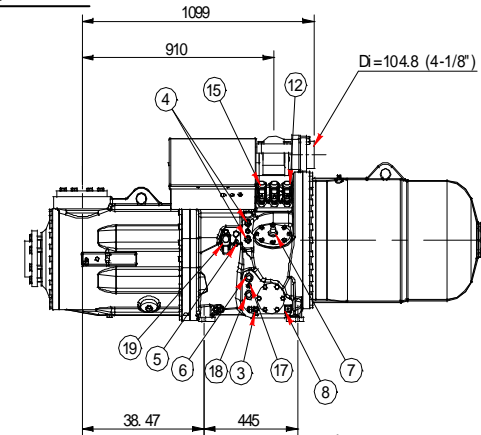
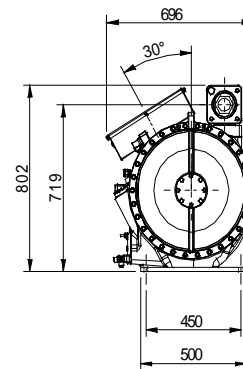
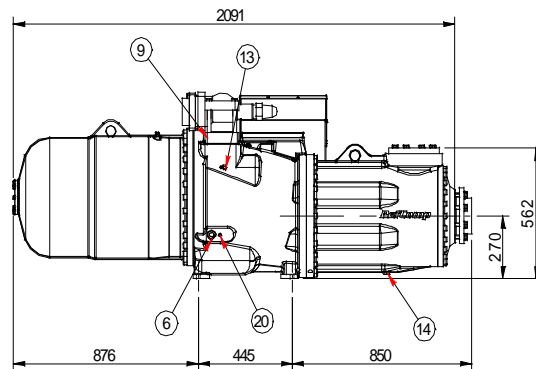

LEGENDA

- 1 - Manicotto aspirazione
- 2 - Rubinetto scarico
- 3 - Rubinetto carico/scarico olio 3/8" SAE-FlARE
- 4 - Connessione raffreddamento olio
- 5 - Pressione olio 1/4" SAE-FlARE
- 6 - Vetro spia olio
- 7 - Filtro olio
- 8 - Riscaldatore olio
- 9 - Valvola di non ritorno
- 10 - Scatola masettiera
- 11 - Bassa pressione 1/4" SAE-FlARE
- 12 - Solenoidi parzializzazione
- 13 - Alta pressione 1/4" SAE-FlARE
- 14 - Scarico olio su coperchio
- 15 - Solenoide controllo capacità continua (opzionale)
- 16 - Raccordo iniezione liquido Ø28/Rubinetto eco Ø42 (opzionale)
- 17 - Sensore temperatura scarico 1/8"NPT (opzionale)
- 18 - Controllo livello (olio) (opzionale)
- 19 - Solenoide controllo V (opzionale)
- 20 - Linea recupero olio 1/4" SAE-FlARE

KEY

- 1 - Suction connection
- 2 - Discharge shut-off valve
- 3 - Oil fill/drain valve 3/8" SAE-FlARE
- 4 - Oil cooler connections
- 5 - Oil pressure 1/4" SAE-FlARE
- 6 - Oil sight glass
- 7 - Oil filter
- 8 - Crankcase heater
- 9 - Non return valve
- 10 - Electrical box
- 11 - Low pressure gas 1/4" SAE-FlARE
- 12 - Solenoid valves for part-load operation
- 13 - High pressure gas 1/4" SAE-FlARE
- 14 - Oil drain motor housing
- 15 - Solenoid valve connection (step-less capacity control)
- 16 - Liquid injection connection Ø28/Economizer shut-off valve Ø42 (optional)
- 17 - Discharge temperature sensor 1/8"NPT (optional)
- 18 - Oil level control (optional)
- 19 - V (oil) control solenoid valve (optional)
- 20 - Oil recovery line 1/4" SAE-FlARE



Figura 8-I: Dimensioni per 134-S-240/270/300 (MSI070 r.01)



LEGENDA

- 1 - Rubinetto aspirazione (opzionale)
- 2 - Rubinetto mandata
- 3 - Rubinetto carico/scarico olio 3/8" SAE-FLARE
- 4 - Connessione raffreddamento olio
- 5 - Pressione olio 1/4" SAE-FLARE
- 6 - Vetro spia olio
- 7 - Filtro olio
- 8 - Riscaldatore olio
- 9 - Valvola di non ritorno
- 10 - Scatola morsettiera
- 11 - Bassa pressione gas 1/4" SAE-FLARE
- 12 - Solenoidi parzializzazione
- 13 - Alta pressione gas 1/4" SAE-FLARE
- 14 - Scarico olio su carcassa M14
- 15 - Iniezione liquido ø16/economizzatore ø22 (opzionale)
- 16 - Sensore temperatura scarico 1/8"NPT (opzionale)

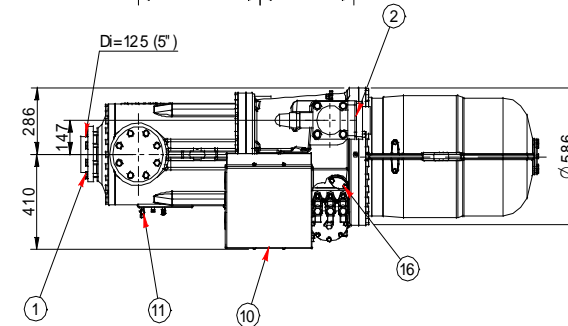
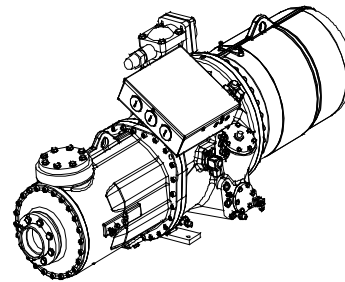
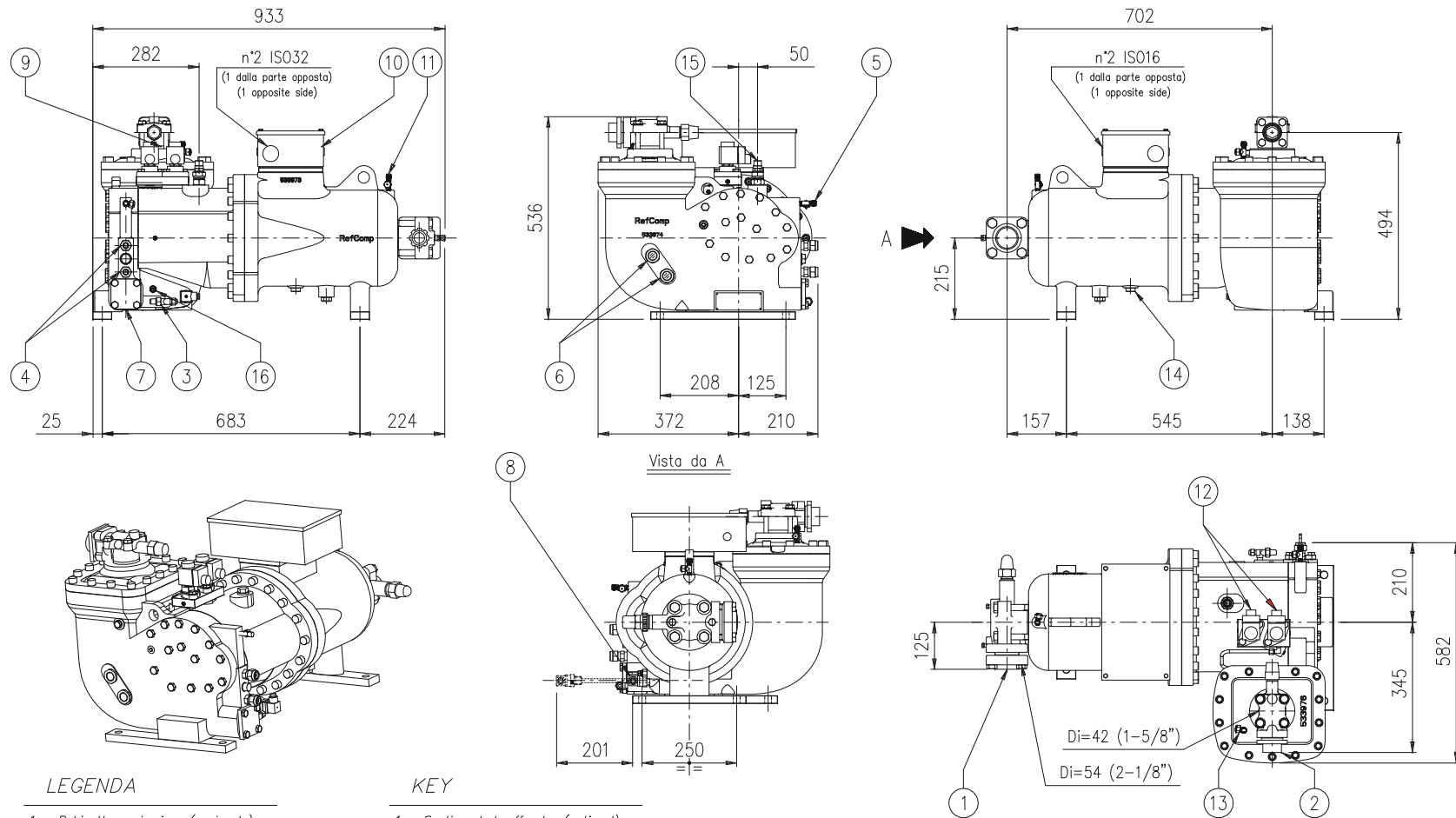
KEY

- 1 - Suction shut-off valve (optional)
- 2 - Discharge shut-off valve
- 3 - Oil fill/drain valve 3/8" SAE-FLARE
- 4 - Oil cooler connections
- 5 - Oil pressure 1/4" SAE-FLARE
- 6 - Oil sight glass
- 7 - Oil filter
- 8 - Crankcase heater
- 9 - Non return valve
- 10 - Electrical box
- 11 - Low pressure gas 1/4" SAE-FLARE
- 12 - Solenoids valve for part-load operation.
- 13 - High pressure gas 1/4" SAE-FLARE
- 14 - Oil drain motor housing M14
- 15 - Liquid injection ø0,63"/economiser ø0,866"(optional)
- 16 - Discharge temperature sensor 1/8"NPT (optional)

Picture 8-J: dimensional drawing of the models: SRC-XS-40/50/60 (drawing code: MSI042 r.01);

8.2 Packaging



Internal packaging structure with cardboard walls;



Packaging with wooden wall;

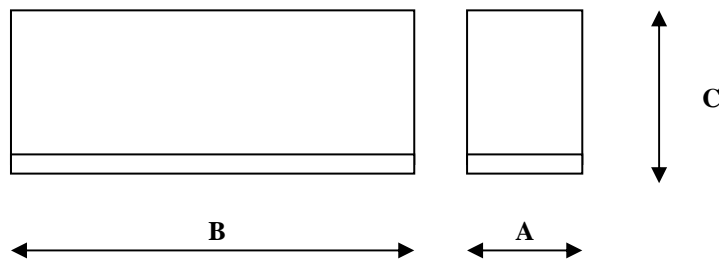

Package dimensions:

Models	A [mm]	B [mm]	C [mm]	
			Wooden packing	Carton packing
SCR – S – 113/133/163	470	1320	675	702
SCR – S – 183/213/253/255/285/303/305	590	1580	840	872
SCR – S – 353/413/463/503/553/603	720	1860	1015	1052
SRC-S – 755	720	1860	1010	1063
SRC-S – 785/885/985	800	2170	1060	1050
SRC-XS-40/50/60	660	1065	722	752

Table A: Packing dimensions (mm);

 	Warning!																			
	The compressors must be moved with a lifter or lifted with appropriate tools used by trained personnel. Compressors weight list follows (the weight has to be considered without the suction shut off valve and without the oil charge):																			
	PESI COMPRESSORI																			
	Modello SRC-XS/S	40	50	60	113	133	163	183	213	253	255	285	303	305	353	413	463	503	553	603
	Peso [KG]	300	305	310	325	330	335	510	515	615	585	590	625	595	730	740	775	1070	1090	1020
PESI COMPRESSORI																				
Modello SRC-S	755	785	885	985																
Peso [Kg]	980	1130	1350	1390																

SRC-XS and SRC-S series compressors

Performance data

(SA-09-03-E)

9.	PERFORMANCE DATA FOR THE SRC-XS AND SRC-S SERIES COMPRESSORS	2
9.1	Performance data with R22 refrigerant	3
9.2	Performance data with R134a refrigerant	8
9.3	Performance data with R407C refrigerant	13
9.4	Performance data with R404A/R507refrigerant	18

9. Performance data for the SRC-XS and SRC-S series compressors

The performances reported in the following tables refer to the following working conditions:

- Gas suction overheating: **SH=10K**;
- Liquid sub-cooling: **SC=5K**;
- Three-phase electrical net frequency: **f=50Hz**;
- Nominal voltage: **V=400V**;
- Refrigerant fluid: **R22, R407C, R134a, R404A e R507**;
- Working conditions without ECONomiser circuit.

Key:

- Te:** Evaporating temperature [° C];
Tc: Condensing temperature [° C];
Pf: Refrigerant power [kW];
Pa: Absorbed power [kW];

	<p>Warning!</p> <ul style="list-style-type: none"> ✓ In order to have performance data for conditions different than those as given above, use RefComp selection program (contact RefComp to have the updated software version); ✓ Performance data are obtained through measurements made at the suction and discharge connection. See chapter SA-08: “<i>Dimensional drawing and packaging</i>” for connection positions on each models; ✓ According to the chapter SA-10: “<i>Application range</i>”, the following tables highlight the working condition which require the monitoring of the filter lodgement (see chapter SA-02) or the additional cooling (see chapter SA-11); ✓ For all the refrigerant mixtures the above mentioned temperatures are the DEW ones. This is valid also for those substances characterized by a glide during the change of phase (R407C, R404A e R507).
---	---

9.1 Performance data with R22 refrigerant

SRC-XS-40/SRC-S-113								
Tcond	30		40		50		60	
Tevap	Pf	Pa	Pf	Pa	Pf	Pa	Pf	Pa
-20	51,2	20,3	42,4	25,0	-	-	-	-
-15	66,0	21,0	54,9	25,9	43,7	31,9	-	-
-10	82,6	21,7	69,5	26,7	55,8	33,1	40,6	40,6
-5	100,9	22,4	86,4	27,6	70,5	34,2	52,6	42,1
0	121,0	23,2	105,5	28,4	87,9	35,2	67,7	43,4
2	129,6	23,5	113,8	28,7	95,7	35,5	74,6	43,9
5	143,0	24,0	126,9	29,1	108,1	36,0	86,0	44,6
10	-	-	150,5	29,9	131,0	36,8	107,5	45,5
12	-	-	160,7	30,2	141,0	37,1	-	-

SRC-XS-50/SRC-S-133								
Tcond	30		40		50		60	
Tevap	Pf	Pa	Pf	Pa	Pf	Pa	Pf	Pa
-20	65,1	25,3	53,9	31,1	-	-	-	-
-15	84,0	26,1	69,8	32,2	55,5	39,7	-	-
-10	105,0	27,0	88,4	33,3	70,9	41,2	51,6	50,5
-5	128,3	27,9	109,8	34,3	89,6	42,6	66,8	52,4
0	153,9	28,9	134,1	35,3	111,8	43,8	86,0	54,1
2	164,7	29,3	144,6	35,7	121,6	44,2	94,9	54,7
5	181,7	29,9	161,3	36,3	137,4	44,9	109,3	55,5
10	-	-	191,4	37,2	166,5	45,8	136,6	56,7
12	-	-	204,3	37,6	179,2	46,1	-	-

SRC-XS-60/SRC-S-163								
Tcond	30		40		50		60	
Tevap	Pf	Pa	Pf	Pa	Pf	Pa	Pf	Pa
-20	73,6	26,5	62,1	32,7	-	-	-	-
-15	92,3	27,4	79,4	33,7	64,8	41,0	-	-
-10	113,6	28,4	99,4	34,7	82,8	42,3	63,7	51,1
-5	137,5	29,6	122,2	35,9	103,6	43,6	81,9	52,8
0	164,0	30,8	147,7	37,1	127,4	45,0	103,2	54,5
2	175,3	31,3	158,7	37,6	137,8	45,6	112,6	55,3
5	193,1	32,2	176,0	38,5	154,1	46,5	127,6	56,3
10	-	-	207,0	39,9	183,8	48,1	155,0	58,2
12	-	-	220,2	40,5	196,4	48,7	-	-

SRC-S-183								
Tcond	30		40		50		60	
Tevap	Pf	Pa	Pf	Pa	Pf	Pa	Pf	Pa
-20	85,3	30,8	72,0	38,0	-	-	-	-
-15	107,1	31,8	92,1	39,0	75,1	47,6	-	-
-10	131,8	33,0	115,3	40,3	96,0	49,0	73,9	59,3
-5	159,5	34,3	141,7	41,6	120,2	50,6	95,0	61,2
0	190,2	35,7	171,3	43,1	147,8	52,2	119,7	63,3
2	203,3	36,4	184,0	43,7	159,8	52,9	130,6	64,1
5	223,9	37,3	204,1	44,6	178,7	53,9	147,9	65,4
10	-	-	240,1	46,3	213,1	55,8	179,7	67,5
12	-	-	255,3	47,0	227,8	56,5	-	-



working conditions which require the monitoring of the filter lodgement. See chapter SA-02.



working conditions which require the additional cooling. See chapter SA-11.

SRC-S-213								
Tcond	30		40		50		60	
Tevap	Pf	Pa	Pf	Pa	Pf	Pa	Pf	Pa
-20	98,7	35,2	83,3	43,4	-	-	-	-
-15	123,8	36,4	106,4	44,7	86,9	54,5	-	-
-10	152,4	37,7	133,3	46,1	110,9	56,1	85,4	67,9
-5	184,4	39,2	163,8	47,6	138,9	57,9	109,8	70,1
0	219,9	40,9	198,1	49,3	170,8	59,8	138,4	72,4
2	235,0	41,6	212,8	50,0	184,7	60,5	150,9	73,4
5	258,8	42,7	235,9	51,1	206,6	61,8	171,0	74,8
10	-	-	277,5	53,0	246,3	63,8	207,8	77,3
12	-	-	295,2	53,8	263,3	64,7	-	-

SRC-S-253/255								
Tcond	30		40		50		60	
Tevap	Pf	Pa	Pf	Pa	Pf	Pa	Pf	Pa
-20	121,3	42,5	102,3	52,4	-	-	-	-
-15	152,2	43,9	130,8	53,9	106,8	65,7	-	-
-10	187,3	45,6	163,9	55,6	136,4	67,7	105,0	81,9
-5	226,7	47,4	201,4	57,5	170,8	69,9	135,0	84,6
0	270,3	49,4	243,5	59,5	210,0	72,1	170,1	87,4
2	289,0	50,2	261,6	60,3	227,1	73,1	185,5	88,6
5	318,2	51,6	290,1	61,6	254,0	74,5	210,2	90,3
10	-	-	341,2	64,0	302,8	77,1	255,4	93,3
12	-	-	362,9	64,9	323,7	78,1	-	-

SRC-S-285 (*)								
Tcond	30		40		50		60	
Tevap	Pf	Pa	Pf	Pa	Pf	Pa	Pf	Pa
-20	135,0	47,2	113,9	58,2	-	-	-	-
-15	169,3	48,8	145,6	59,9	118,8	73,0	-	-
-10	208,4	50,6	182,3	61,7	151,8	75,2	116,9	90,9
-5	252,2	52,6	224,1	63,8	190,1	77,6	150,2	93,9
0	300,8	54,8	270,9	66,0	233,7	80,1	189,3	97,0
2	321,5	55,7	291,1	67,0	252,7	81,1	206,5	98,3
5	354,1	57,2	322,8	68,4	282,7	82,7	233,9	100,2
10	-	-	379,6	71,0	337,0	85,5	284,3	103,5
12	-	-	403,8	72,1	360,2	86,7	-	-

SRC-S-303/305								
Tcond	30		40		50		60	
Tevap	Pf	Pa	Pf	Pa	Pf	Pa	Pf	Pa
-20	146,1	51,2	123,3	63,1	-	-	-	-
-15	183,3	52,9	157,6	65,0	128,6	79,1	-	-
-10	225,6	54,9	197,4	67,0	164,3	81,6	126,5	98,7
-5	273,0	57,0	242,6	69,2	205,7	84,1	162,6	101,9
0	325,6	59,4	293,3	71,6	253,0	86,9	204,9	105,3
2	348,0	60,5	315,1	72,6	273,5	88,0	223,5	106,6
5	383,3	62,1	349,4	74,2	306,0	89,7	253,2	108,7
10	-	-	410,9	77,0	364,8	92,8	307,7	112,3
12	-	-	437,1	78,2	389,9	94,0	-	-



working conditions which require the monitoring of the filter lodgement. See chapter SA-02.



working conditions which require the additional cooling. See chapter SA-11.

(*)

not final data.

SRC-S-353								
Tcond	30		40		50		60	
Tevap	Pf	Pa	Pf	Pa	Pf	Pa	Pf	Pa
-20	174,0	60,2	146,9	74,2	-	-	-	-
-15	218,3	62,2	187,7	76,4	153,2	93,1	-	-
-10	268,7	64,5	235,1	78,8	195,7	95,9	150,7	116,0
-5	325,3	67,1	289,0	81,4	245,1	98,9	193,7	119,8
0	387,9	69,9	349,4	84,2	301,4	102,1	244,1	123,8
2	414,6	71,1	375,3	85,4	325,8	103,5	266,2	125,4
5	456,6	73,0	416,2	87,3	364,5	105,5	301,7	127,8
10	-	-	489,5	90,6	434,5	109,1	366,5	132,1
12	-	-	520,7	91,9	464,5	110,6	-	-

SRC-S-413								
Tcond	30		40		50		60	
Tevap	Pf	Pa	Pf	Pa	Pf	Pa	Pf	Pa
-20	194,4	66,7	164,1	82,2	-	-	-	-
-15	243,9	68,9	209,8	84,6	171,2	103,1	-	-
-10	300,3	71,4	262,7	87,2	218,7	106,2	168,4	128,5
-5	363,4	74,3	322,9	90,1	273,9	109,5	216,5	132,7
0	433,4	77,4	390,4	93,3	336,7	113,1	272,7	137,0
2	463,3	78,7	419,4	94,6	364,0	114,6	297,5	138,8
5	510,1	80,8	465,1	96,7	407,3	116,9	337,1	141,6
10	-	-	547,0	100,3	485,5	120,8	409,6	146,3
12	-	-	581,8	101,8	519,0	122,4	-	-

SRC-S-463								
Tcond	30		40		50		60	
Tevap	Pf	Pa	Pf	Pa	Pf	Pa	Pf	Pa
-20	216,5	82,5	180,2	97,1	-	-	-	-
-15	263,6	82,4	225,8	98,4	186,9	119,4	-	-
-10	322,3	83,1	282,5	100,1	240,2	122,2	194,3	149,1
-5	392,6	84,8	350,1	102,1	303,8	125,0	252,7	152,8
0	474,7	87,3	428,9	104,6	378,0	127,7	321,0	156,0
2	510,9	88,6	463,5	105,7	410,6	128,7	351,0	157,1
5	568,6	90,8	518,8	107,5	462,7	130,3	399,1	158,6
10	-	-	620,0	110,9	558,0	132,8	487,3	160,6
12	-	-	663,6	112,4	599,1	133,9	-	-

SRC-S-503								
Tcond	30		40		50		60	
Tevap	Pf	Pa	Pf	Pa	Pf	Pa	Pf	Pa
-20	238,6	90,9	198,6	107,0	-	-	-	-
-15	290,5	90,8	248,9	108,4	205,9	131,5	-	-
-10	355,1	91,6	311,3	110,3	264,6	134,7	214,1	164,3
-5	432,7	93,4	385,8	112,5	334,8	137,7	278,5	168,4
0	523,1	96,2	472,6	115,3	416,5	140,7	353,7	171,9
2	562,9	97,6	510,8	116,5	452,5	141,8	386,8	173,1
5	626,6	100,1	571,7	118,5	509,9	143,6	439,8	174,7
10	-	-	683,2	122,2	614,9	146,4	537,0	177,0
12	-	-	731,2	123,8	660,2	147,5	-	-



working conditions which require the monitoring of the filter lodgement. See chapter SA-02.

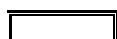

working conditions which require the additional cooling. See chapter SA-11.

SRC-S-553								
Tcond	30		40		50		60	
Tevap	Pf	Pa	Pf	Pa	Pf	Pa	Pf	Pa
-20	254,7	97,0	212,0	114,2	-	-	-	-
-15	310,1	96,9	265,7	115,8	219,9	140,4	-	-
-10	379,1	97,8	332,3	117,7	282,5	143,8	228,5	175,4
-5	461,9	99,7	411,9	120,2	357,5	147,1	297,3	179,8
0	558,5	102,7	504,6	123,1	444,7	150,2	377,6	183,5
2	601,0	104,2	545,3	124,4	483,1	151,4	413,0	184,8
5	669,0	106,8	610,4	126,5	544,3	153,3	469,6	186,6
10	-	-	729,4	130,5	656,4	156,3	573,3	189,0
12	-	-	780,7	132,2	704,8	157,5	-	-

SRC-S-603								
Tcond	30		40		50		60	
Tevap	Pf	Pa	Pf	Pa	Pf	Pa	Pf	Pa
-20	311,8	108,7	273,4	130,5	-	-	-	-
-15	385,2	112,3	340,3	134,7	296,7	162,5	-	-
-10	468,8	117,2	418,0	139,7	365,8	168,5	311,9	203,5
-5	562,7	123,5	506,3	145,6	446,0	174,8	381,5	211,0
0	666,9	131,1	605,3	152,4	537,4	181,4	462,7	218,3
2	711,5	134,5	647,9	155,3	577,0	184,2	498,4	221,2
5	781,5	140,1	715,1	159,9	639,9	188,4	555,5	225,5
10	-	-	835,6	168,4	753,6	195,7	659,8	232,6
12	-	-	886,9	172,0	802,2	198,8	-	-

SRC-S-755								
Tcond	30		40		50		60	
Tevap	Pf	Pa	Pf	Pa	Pf	Pa	Pf	Pa
-16	429,7	132,6	366,3	165,8	-	-	-	-
-15	448,2	133,2	384,1	166,9	295,1	195,6	-	-
-10	547,2	136,4	476,1	171,8	389,7	206,6	303,1	225,7
-5	661,5	140,1	577,2	175,7	487,2	215,0	406,6	243,0
0	796,6	144,9	692,8	179,0	593,0	221,2	512,2	256,5
2	857,6	147,2	744,4	180,2	638,9	223,2	556,3	261,0
5	957,8	151,0	828,5	182,1	712,7	225,7	625,5	266,7
10	-	-	989,6	185,4	851,7	228,8	752,0	273,9
15	-	-	1181,8	189,3	1015,5	230,9	-	-

SRC-S-785								
Tcond	30		40		50		60	
Tevap	Pf	Pa	Pf	Pa	Pf	Pa	Pf	Pa
-20	431,5	148,9	378,3	178,8	-	-	-	-
-15	533,0	153,8	471,0	184,6	410,5	222,7	-	-
-10	648,8	160,6	578,4	191,5	506,2	230,8	431,6	278,8
-5	778,7	169,2	700,6	199,5	617,2	239,4	528,0	289,0
0	923,0	179,6	837,7	208,8	743,6	248,5	640,3	299,1
2	984,6	184,3	896,7	212,8	798,5	252,3	689,8	303,1
5	1081,5	191,9	989,6	219,1	885,5	258,1	768,7	309,0
10	-	-	1156,4	230,7	1042,9	268,2	913,2	318,6
12	-	-	1227,3	235,6	1110,2	272,3	-	-

SRC-S-885								
Tcond	30		40		50		60	
Tevap	Pf	Pa	Pf	Pa	Pf	Pa	Pf	Pa
-20	487,2	168,1	427,2	201,9	-	-	-	-
-15	601,9	173,7	531,8	208,4	463,6	251,5	-	-
-10	732,6	181,3	653,1	216,2	571,6	260,6	487,3	314,8
-5	879,3	191,0	791,1	225,3	696,9	270,4	596,2	326,4
0	1042,2	202,8	945,9	235,7	839,7	280,7	723,1	337,7
2	1111,8	208,1	1012,5	240,3	901,7	284,9	778,9	342,2
5	1221,2	216,7	1117,4	247,4	999,9	291,5	868,0	348,9
10	-	-	1305,8	260,5	1177,6	302,8	1031,1	359,8
12	-	-	1385,9	266,0	1253,6	307,5	-	-

SRC-S-985								
Tcond	30		40		50		60	
Tevap	Pf	Pa	Pf	Pa	Pf	Pa	Pf	Pa
-20	544,0	187,7	477,0	225,4	-	-	-	-
-15	672,0	193,9	593,8	232,7	517,6	280,8	-	-
-10	817,9	202,5	729,2	241,4	638,2	291,0	544,1	351,5
-5	981,8	213,3	883,3	251,6	778,2	301,9	665,6	364,4
0	1163,6	226,5	1056,1	263,2	937,6	313,4	807,3	377,1
2	1241,4	232,4	1130,5	268,3	1006,8	318,1	869,6	382,1
5	1363,5	241,9	1247,6	276,3	1116,4	325,4	969,2	389,5
10	-	-	1458,0	290,8	1314,8	338,1	1151,3	401,7
12	-	-	1547,3	297,0	1399,6	343,3	-	-



working conditions which require the monitoring of the filter lodgement. See chapter SA-02.



working conditions which require the additional cooling. See chapter SA-11.

9.2 Performance data with R134a refrigerant

SRC-XS-40/SRC-S-113								
Tcond	40		50		60		70	
Tevap	Pf	Pa	Pf	Pa	Pf	Pa	Pf	Pa
-20	25,5	16,0	-	-	-	-	-	-
-15	33,8	16,7	27,2	20,4	-	-	-	-
-10	44,1	17,3	35,9	21,2	-	-	-	-
-5	56,3	17,8	46,6	21,9	36,5	26,7	-	-
0	70,5	18,1	59,4	22,5	47,8	27,6	35,3	32,9
2	76,8	18,2	65,1	22,7	52,9	27,9	39,7	33,4
5	86,7	18,4	74,3	23,0	61,1	28,4	47,0	34,1
10	104,9	18,5	91,2	23,4	76,7	29,1	61,0	35,1
15	125,2	18,6	110,3	23,7	94,3	29,7	77,2	36,1
20	-	-	131,4	23,9	114,2	30,2	95,6	37,0

SRC-XS-50/SRC-S-133								
Tcond	40		50		60		70	
Tevap	Pf	Pa	Pf	Pa	Pf	Pa	Pf	Pa
-20	32,4	20,3	-	-	-	-	-	-
-15	43,0	21,2	34,6	25,9	-	-	-	-
-10	56,0	22,0	45,6	27,0	-	-	-	-
-5	71,6	22,6	59,3	27,8	46,4	33,9	-	-
0	89,7	23,0	75,6	28,6	60,7	35,1	44,8	41,9
2	97,6	23,2	82,8	28,9	67,2	35,5	50,5	42,5
5	110,3	23,4	94,5	29,2	77,7	36,1	59,8	43,3
10	133,4	23,5	116,0	29,7	97,5	36,9	77,5	44,7
15	159,1	23,6	140,2	30,1	119,9	37,7	98,1	45,9
20	-	-	167,0	30,4	145,1	38,4	121,5	47,1

SRC-XS-60/SRC-S-163								
Tcond	40		50		60		70	
Tevap	Pf	Pa	Pf	Pa	Pf	Pa	Pf	Pa
-20	37,7	21,4	-	-	-	-	-	-
-15	49,1	22,2	39,9	26,6	-	-	-	-
-10	63,1	22,9	52,4	27,5	-	-	-	-
-5	79,8	23,6	67,6	28,5	53,4	34,4	-	-
0	99,0	24,3	85,4	29,4	69,5	35,6	51,2	42,7
2	107,4	24,6	93,3	29,8	76,7	36,1	57,6	43,3
5	120,7	24,9	105,8	30,3	88,2	36,8	67,9	44,2
10	144,9	25,5	128,6	31,2	109,4	37,9	87,2	45,6
15	171,6	25,9	154,0	31,9	133,1	38,9	108,9	47,0
20	-	-	181,8	32,6	159,3	39,9	133,2	48,3

SRC-S-183								
Tcond	40		50		60		70	
Tevap	Pf	Pa	Pf	Pa	Pf	Pa	Pf	Pa
-20	43,7	24,8	-	-	-	-	-	-
-15	56,9	25,7	46,2	30,8	-	-	-	-
-10	73,2	26,6	60,8	31,9	-	-	-	-
-5	92,5	27,4	78,4	33,1	62,0	39,9	-	-
0	114,7	28,2	99,1	34,2	80,6	41,3	59,4	49,6
2	124,5	28,5	108,2	34,6	88,9	41,8	66,8	50,2
5	139,9	28,9	122,7	35,2	102,2	42,6	78,8	51,3
10	168,1	29,6	149,2	36,2	126,8	43,9	101,1	52,9
15	199,0	30,1	178,6	37,0	154,3	45,2	126,3	54,5
20	-	-	210,8	37,8	184,7	46,3	154,5	56,0

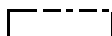

working conditions which require the monitoring of the filter lodgement. See chapter SA-02.

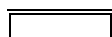

working conditions which require the additional cooling. See chapter SA-11.

SRC-S-213								
Tcond	40		50		60		70	
Tevap	Pf	Pa	Pf	Pa	Pf	Pa	Pf	Pa
-20	50,5	28,4	-	-	-	-	-	-
-15	65,8	29,4	53,4	35,2	-	-	-	-
-10	84,6	30,4	70,3	36,6	-	-	-	-
-5	106,9	31,4	90,7	37,8	71,6	45,6	-	-
0	132,6	32,3	114,5	39,1	93,2	47,2	68,7	56,7
2	143,9	32,6	125,0	39,6	102,8	47,9	77,2	57,5
5	161,8	33,1	141,8	40,3	118,2	48,8	91,0	58,7
10	194,3	33,8	172,4	41,4	146,6	50,3	116,8	60,6
15	230,1	34,4	206,4	42,4	178,4	51,7	146,0	62,4
20	-	-	243,7	43,2	213,5	53,0	178,5	64,1

SRC-S-253/255								
Tcond	40		50		60		70	
Tevap	Pf	Pa	Pf	Pa	Pf	Pa	Pf	Pa
-20	62,0	34,2	-	-	-	-	-	-
-15	81,0	35,5	65,7	42,5	-	-	-	-
-10	104,1	36,7	86,5	44,1	-	-	-	-
-5	131,5	37,9	111,6	45,7	88,2	55,1	-	-
0	163,1	38,9	140,9	47,2	114,7	57,0	84,5	68,4
2	176,9	39,3	153,8	47,7	126,4	57,8	94,9	69,4
5	198,9	39,9	174,4	48,6	145,4	58,9	111,9	70,8
10	239,0	40,8	212,2	50,0	180,4	60,7	143,6	73,0
15	283,4	41,7	254,2	51,3	219,6	62,5	179,6	75,3
20	-	-	300,5	52,5	263,2	64,2	219,9	77,5

SRC-S-285 (*)								
Tcond	40		50		60		70	
Tevap	Pf	Pa	Pf	Pa	Pf	Pa	Pf	Pa
-20	69,0	38,0	-	-	-	-	-	-
-15	90,1	39,4	73,1	47,2	-	-	-	-
-10	115,9	40,8	96,3	49,0	-	-	-	-
-5	146,3	42,0	124,2	50,7	98,1	61,1	-	-
0	181,5	43,2	156,8	52,3	127,6	63,3	94,0	76,0
2	196,9	43,6	171,1	53,0	140,7	64,1	105,6	77,0
5	221,4	44,3	194,1	53,9	161,8	65,3	124,5	78,5
10	266,0	45,3	236,1	55,4	200,7	67,4	159,8	81,1
15	315,3	46,3	282,9	56,9	244,4	69,3	199,9	83,6
20	-	-	334,4	58,3	292,9	71,3	244,7	86,1

SRC-S-303/305								
Tcond	40		50		60		70	
Tevap	Pf	Pa	Pf	Pa	Pf	Pa	Pf	Pa
-20	74,6	41,2	-	-	-	-	-	-
-15	97,4	42,8	79,1	51,2	-	-	-	-
-10	125,3	44,2	104,1	53,2	-	-	-	-
-5	158,3	45,6	134,3	55,0	106,1	66,3	-	-
0	196,3	46,9	169,5	56,8	138,0	68,6	101,7	82,4
2	212,9	47,4	185,1	57,5	152,2	69,6	114,3	83,5
5	239,4	48,1	209,9	58,5	175,0	70,9	134,7	85,2
10	287,7	49,2	255,4	60,2	217,1	73,1	172,9	88,0
15	341,0	50,2	306,0	61,7	264,3	75,2	216,2	90,7
20	-	-	361,7	63,3	316,8	77,3	264,7	93,4



working conditions which require the monitoring of the filter lodgement. See chapter SA-02.

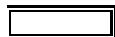

working conditions which require the additional cooling. See chapter SA-11.

(*)

not final data.

SRC-S-353								
Tcond	40		50		60		70	
Tevap	Pf	Pa	Pf	Pa	Pf	Pa	Pf	Pa
-20	89,1	48,6	-	-	-	-	-	-
-15	116,1	50,3	94,2	60,2	-	-	-	-
-10	149,2	52,0	124,0	62,5	-	-	-	-
-5	188,6	53,6	159,9	64,7	126,3	78,0	-	-
0	234,0	55,2	202,0	66,8	164,4	80,7	121,2	96,9
2	253,8	55,7	220,5	67,6	181,3	81,8	136,2	98,3
5	285,4	56,6	250,1	68,8	208,5	83,4	160,6	100,3
10	342,7	57,8	304,2	70,7	258,6	85,9	206,1	103,5
15	405,8	58,8	364,1	72,4	314,7	88,3	257,6	106,7
20	-	-	429,9	73,9	376,6	90,5	315,0	109,6

SRC-S-413								
Tcond	40		50		60		70	
Tevap	Pf	Pa	Pf	Pa	Pf	Pa	Pf	Pa
-20	99,6	53,8	-	-	-	-	-	-
-15	129,7	55,7	105,3	66,7	-	-	-	-
-10	166,8	57,6	138,6	69,2	-	-	-	-
-5	210,7	59,4	178,7	71,6	141,2	86,3	-	-
0	261,4	61,1	225,7	74,0	183,7	89,4	135,4	107,3
2	283,6	61,7	246,4	74,9	202,6	90,6	152,2	108,8
5	318,9	62,6	279,5	76,2	233,0	92,3	179,5	111,0
10	382,9	64,0	339,9	78,3	289,0	95,2	230,3	114,6
15	453,5	65,1	406,8	80,2	351,6	97,8	287,8	118,1
20	-	-	480,3	81,8	420,8	100,3	351,9	121,4

SRC-S-463								
Tcond	40		50		60		70	
Tevap	Pf	Pa	Pf	Pa	Pf	Pa	Pf	Pa
-20	108,1	64,2	-	-	-	-	-	-
-15	138,3	65,4	113,6	77,8	-	-	-	-
-10	178,4	66,5	152,3	79,7	-	-	-	-
-5	228,4	67,6	199,5	81,4	167,6	98,6	-	-
0	288,2	68,5	255,1	83,0	217,8	101,1	176,9	122,8
2	314,9	68,8	279,8	83,5	239,9	102,0	196,0	124,2
5	357,7	69,3	319,2	84,4	275,1	103,3	226,2	126,1
10	436,9	69,9	391,5	85,6	339,3	105,4	281,1	129,2
15	525,7	70,4	472,0	86,6	410,4	107,2	341,5	132,0
20	-	-	560,7	87,4	488,2	108,7	407,3	134,6

SRC-S-503								
Tcond	40		50		60		70	
Tevap	Pf	Pa	Pf	Pa	Pf	Pa	Pf	Pa
-20	118,3	70,7	-	-	-	-	-	-
-15	152,2	72,0	124,3	85,8	-	-	-	-
-10	196,7	73,3	167,4	87,8	-	-	-	-
-5	251,6	74,4	219,5	89,7	184,3	108,7	-	-
0	317,2	75,5	280,8	91,4	240,1	111,4	195,0	135,4
2	346,4	75,8	307,9	92,1	264,5	112,4	216,4	136,8
5	393,5	76,3	351,3	93,0	303,6	113,9	250,4	139,0
10	480,5	77,0	431,0	94,3	374,9	116,1	312,0	142,4
15	578,4	77,6	520,1	95,5	454,0	118,1	380,1	145,4
20	-	-	618,7	96,3	541,1	119,8	454,5	148,2

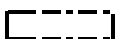

working conditions which require the monitoring of the filter lodgement. See chapter SA-02.

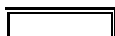

working conditions which require the additional cooling. See chapter SA-11.

SRC-S-553								
Tcond	40		50		60		70	
Tevap	Pf	Pa	Pf	Pa	Pf	Pa	Pf	Pa
-20	126,5	75,2	-	-	-	-	-	-
-15	162,7	76,7	132,9	91,5	-	-	-	-
-10	210,1	78,2	178,7	93,8	-	-	-	-
-5	268,7	79,5	234,3	95,8	196,4	116,2	-	-
0	338,6	80,6	299,6	97,7	256,1	119,0	208,0	144,5
2	369,8	81,0	328,5	98,4	282,3	120,1	231,1	146,0
5	419,9	81,6	374,9	99,4	324,1	121,6	267,7	148,2
10	512,7	82,4	460,1	100,8	400,6	123,9	334,2	151,6
15	617,0	83,0	555,3	102,0	485,5	125,8	407,8	154,6
20	-	-	660,6	102,9	579,1	127,5	488,4	157,3

SRC-S-603								
Tcond	40		50		60		70	
Tevap	Pf	Pa	Pf	Pa	Pf	Pa	Pf	Pa
-20	166,2	85,2	-	-	-	-	-	-
-15	211,1	88,7	182,9	105,2	-	-	-	-
-10	265,9	92,3	231,9	109,8	-	-	-	-
-5	330,6	96,0	290,8	114,2	248,0	137,3	-	-
0	405,2	99,7	359,6	118,6	310,9	142,3	259,0	171,0
2	437,8	101,2	389,9	120,3	338,8	144,2	284,5	173,2
5	489,7	103,5	438,4	122,8	383,7	147,0	325,8	176,3
10	584,2	107,4	527,0	126,8	466,5	151,4	402,5	181,2
15	688,5	111,4	625,6	130,8	559,2	155,5	489,1	185,5
20	-	-	734,1	134,7	661,8	159,3	585,7	189,4

SRC-S-755								
Tcond	40		50		60		70	
Tevap	Pf	Pa	Pf	Pa	Pf	Pa	Pf	Pa
-16	232,5	99,0	-	-	-	-	-	-
-15	244,0	99,8	208,6	-	-	-	-	-
-10	307,3	103,9	265,9	-	-	-	-	-
-5	380,9	108,2	332,9	128,8	279,3	155,6	-	-
0	466,5	113,4	411,2	134,1	347,9	161,7	279,0	196,6
2	504,4	115,8	446,0	136,4	378,7	164,2	304,8	199,6
5	565,4	119,9	502,3	140,1	428,8	168,1	347,2	204,1
10	679,3	128,1	607,7	147,4	523,4	175,2	428,6	211,9
15	-	-	729,0	156,6	633,1	183,6	524,5	220,4

SRC-S-785								
Tcond	40		50		60		70	
Tevap	Pf	Pa	Pf	Pa	Pf	Pa	Pf	Pa
-20	210,0	105,2	-	-	-	-	-	-
-15	270,2	110,0	231,0	130,7	-	-	-	-
-10	340,3	114,4	294,5	136,4	-	-	-	-
-5	421,9	119,2	368,7	141,9	309,3	171,4	-	-
0	516,6	124,9	455,4	147,7	385,3	178,2	309,0	216,6
2	558,5	127,6	493,9	150,2	419,4	180,9	337,6	219,9
5	626,2	132,0	566,3	154,4	474,9	185,2	384,6	224,9
10	752,3	141,2	673,0	162,4	579,6	193,1	474,6	233,4
15	896,6	152,9	807,3	172,5	701,2	202,3	580,9	242,8
20	-	-	960,8	185,1	841,3	213,6	706,0	253,5

SRC-S-885								
Tcond	40		50		60		70	
Tevap	Pf	Pa	Pf	Pa	Pf	Pa	Pf	Pa
-20	237,1	117,6	-	-	-	-	-	-
-15	305,2	122,8	260,9	146,0	-	-	-	-
-10	384,3	127,9	332,5	152,4	-	-	-	-
-5	476,4	133,2	416,3	158,6	349,2	191,5	-	-
0	583,3	139,6	514,2	165,0	435,1	199,0	348,9	242,0
2	630,7	142,5	557,7	167,8	473,6	202,1	381,2	245,7
5	707,1	147,5	628,1	172,4	536,2	206,9	434,2	251,3
10	849,5	157,7	759,9	181,5	654,4	215,7	536,9	260,8
15	1012,5	170,8	911,6	192,7	791,7	226,1	656,9	271,2
20	-	-	1086,0	206,8	960,0	238,6	796,0	283,2

SRC-S-985								
Tcond	40		50		60		70	
Tevap	Pf	Pa	Pf	Pa	Pf	Pa	Pf	Pa
-20	264,7	133,5	-	-	-	-	-	-
-15	340,7	139,5	291,3	165,8	-	-	-	-
-10	429,1	145,2	371,2	173,1	-	-	-	-
-5	531,9	151,3	464,8	180,1	389,9	217,5	-	-
0	651,3	158,5	574,1	187,4	485,8	226,1	389,6	274,9
2	704,2	161,9	622,7	190,6	528,8	229,5	425,6	279,1
5	789,4	167,6	701,3	195,9	598,7	235,0	484,8	285,4
10	948,5	179,1	848,5	206,1	730,7	245,0	598,4	296,2
15	1130,5	194,0	1017,8	218,9	884,0	256,7	732,3	308,1
20	-	-	1211,4	234,9	1060,7	271,0	888,8	321,7



working conditions which require the monitoring of the filter lodgement. See chapter SA-02.



working conditions which require the additional cooling. See chapter SA-11.

9.3 Performance data with R407C refrigerant

SRC-XS-40/SRC-S-113								
Tcond	30		40		50		60	
Tevap	Pf	Pa	Pf	Pa	Pf	Pa	Pf	Pa
-16	57,7	20,7	45,9	24,7	-	-	-	-
-15	60,7	20,8	48,4	24,9	-	-	-	-
-10	76,9	21,3	62,7	25,7	49,0	31,8	-	-
-5	95,5	21,8	79,8	26,5	63,2	33,0	-	-
0	116,5	22,2	99,6	27,2	80,6	34,2	58,7	42,7
2	125,6	22,3	108,3	27,5	88,5	34,6	65,2	43,3
5	139,9	22,5	122,3	27,9	101,2	35,3	75,9	44,3
10	-	-	147,7	28,5	125,0	36,3	96,8	45,9
15	-	-	176,0	29,1	152,1	37,3	-	-

SRC-XS-50/SRC-S-133								
Tcond	30		40		50		60	
Tevap	Pf	Pa	Pf	Pa	Pf	Pa	Pf	Pa
-16	73,4	25,7	58,3	30,8	-	-	-	-
-15	77,2	25,9	61,5	31,0	-	-	-	-
-10	97,8	26,5	79,7	32,1	62,3	39,6	-	-
-5	121,4	27,1	101,4	33,0	80,4	41,1	-	-
0	148,1	27,6	126,6	33,9	102,5	42,5	74,6	53,1
2	159,6	27,8	137,7	34,3	112,5	43,1	82,8	54,0
5	177,8	28,1	155,4	34,8	128,7	43,9	96,5	55,2
10	-	-	187,8	35,5	159,0	45,2	123,1	57,2
15	-	-	223,8	36,3	193,3	46,5	-	-

SRC-XS-60/SRC-S-163								
Tcond	30		40		50		60	
Tevap	Pf	Pa	Pf	Pa	Pf	Pa	Pf	Pa
-16	77,7	27,1	62,0	33,9	-	-	-	-
-15	81,8	27,2	65,9	34,0	-	-	-	-
-10	104,6	27,7	87,3	34,5	68,3	43,2	-	-
-5	130,5	28,4	111,6	35,3	90,3	44,1	-	-
0	159,7	29,4	139,0	36,2	115,2	45,2	88,4	56,5
2	172,2	29,8	150,8	36,7	125,9	45,8	97,8	57,1
5	192,0	30,6	169,4	37,5	142,8	46,6	112,6	58,1
10	-	-	202,7	38,9	173,3	48,2	139,5	59,9
15	-	-	239,1	40,7	206,6	50,1	-	-

SRC-S-183								
Tcond	30		40		50		60	
Tevap	Pf	Pa	Pf	Pa	Pf	Pa	Pf	Pa
-16	90,1	31,5	71,9	39,4	-	-	-	-
-15	94,9	31,5	76,5	39,4	-	-	-	-
-10	121,3	32,1	101,2	40,0	79,2	50,2	-	-
-5	151,3	33,0	129,5	40,9	104,8	51,2	-	-
0	185,1	34,1	161,2	42,0	133,6	52,5	102,5	65,5
2	199,7	34,6	174,8	42,6	146,0	53,1	113,4	66,2
5	222,7	35,5	196,4	43,5	165,7	54,1	130,6	67,4
10	-	-	235,1	45,2	201,0	55,9	161,7	69,5
15	-	-	277,3	47,2	239,5	58,1	-	-



working conditions which require the monitoring of the filter lodgement. See chapter SA-02.

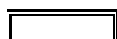

working conditions which require the additional cooling. See chapter SA-11.

SRC-S-213								
Tcond	30		40		50		60	
Tevap	Pf	Pa	Pf	Pa	Pf	Pa	Pf	Pa
-16	104,1	36,0	83,1	45,1	-	-	-	-
-15	109,7	36,1	88,4	45,2	-	-	-	-
-10	140,2	36,8	117,0	45,8	91,5	57,4	-	-
-5	175,0	37,7	149,7	46,8	121,1	58,6	-	-
0	214,0	39,0	186,3	48,1	154,4	60,1	118,5	75,0
2	230,9	39,6	202,1	48,7	168,8	60,8	131,1	75,8
5	257,4	40,6	227,0	49,8	191,5	61,9	151,0	77,1
10	-	-	271,8	51,7	232,3	64,0	187,0	79,6
15	-	-	320,5	54,0	276,9	66,5	-	-

SRC-S-253/255								
Tcond	30		40		50		60	
Tevap	Pf	Pa	Pf	Pa	Pf	Pa	Pf	Pa
-16	128,0	43,5	102,2	54,4	-	-	-	-
-15	134,9	43,6	108,7	54,5	-	-	-	-
-10	172,3	44,4	143,9	55,3	112,5	69,3	-	-
-5	215,1	45,5	184,0	56,5	148,9	70,7	-	-
0	263,1	47,1	229,1	58,1	189,9	72,5	145,7	90,5
2	283,8	47,8	248,5	58,8	207,5	73,3	161,1	91,5
5	316,5	49,0	279,1	60,1	235,4	74,7	185,6	93,1
10	-	-	334,1	62,4	285,6	77,3	229,9	96,0
15	-	-	394,1	65,2	340,4	80,2	-	-

SRC-S-285 (*)								
Tcond	30		40		50		60	
Tevap	Pf	Pa	Pf	Pa	Pf	Pa	Pf	Pa
-16	142,5	48,3	113,7	60,4	-	-	-	-
-15	150,1	48,4	120,9	60,5	-	-	-	-
-10	191,8	49,2	160,1	61,4	125,2	76,9	-	-
-5	239,3	50,5	204,8	62,7	165,7	78,5	-	-
0	292,8	52,3	254,9	64,5	211,3	80,5	162,1	100,4
2	315,8	53,1	276,5	65,3	230,9	81,4	179,3	101,5
5	352,1	54,4	310,6	66,7	262,0	82,9	206,6	103,3
10	-	-	371,8	69,3	317,8	85,8	255,8	106,6
15	-	-	438,5	72,3	378,8	89,1	-	-

SRC-S-303/305								
Tcond	30		40		50		60	
Tevap	Pf	Pa	Pf	Pa	Pf	Pa	Pf	Pa
-16	154,2	52,3	123,1	65,5	-	-	-	-
-15	162,5	52,5	130,9	65,6	-	-	-	-
-10	207,6	53,4	173,3	66,6	135,5	83,5	-	-
-5	259,1	54,8	221,6	68,0	179,3	85,2	-	-
0	316,9	56,7	275,9	69,9	228,7	87,3	175,5	109,0
2	341,9	57,6	299,3	70,8	250,0	88,3	194,1	110,1
5	381,2	59,0	336,2	72,3	283,6	89,9	223,6	112,1
10	-	-	402,4	75,1	344,0	93,0	276,9	115,6
15	-	-	474,7	78,5	410,0	96,6	-	-



working conditions which require the monitoring of the filter lodgement. See chapter SA-02.



working conditions which require the additional cooling. See chapter SA-11.

(*)

not final data.

SRC-S-353								
Tcond	30		40		50		60	
Tevap	Pf	Pa	Pf	Pa	Pf	Pa	Pf	Pa
-16	183,7	61,5	146,7	77,0	-	-	-	-
-15	193,5	61,7	155,9	77,2	-	-	-	-
-10	247,3	62,8	206,4	78,3	161,5	98,1	-	-
-5	308,6	64,5	264,0	80,0	213,6	100,1	-	-
0	377,6	66,7	328,7	82,2	272,4	102,7	209,0	128,1
2	407,3	67,7	356,6	83,3	297,8	103,8	231,2	129,5
5	454,1	69,4	400,5	85,0	337,8	105,8	266,4	131,8
10	-	-	479,4	88,4	409,8	109,4	329,8	136,0
15	-	-	565,4	92,2	488,5	113,6	-	-

SRC-S-413								
Tcond	30		40		50		60	
Tevap	Pf	Pa	Pf	Pa	Pf	Pa	Pf	Pa
-16	205,2	68,2	163,9	85,3	-	-	-	-
-15	216,2	68,3	174,2	85,4	-	-	-	-
-10	276,3	69,6	230,6	86,7	180,4	108,7	-	-
-5	344,8	71,4	295,0	88,6	238,7	110,9	-	-
0	421,9	73,8	367,3	91,1	304,4	113,7	233,5	141,9
2	455,1	75,0	398,4	92,2	332,7	115,0	258,3	143,4
5	507,4	76,8	447,5	94,2	377,5	117,1	297,6	145,9
10	-	-	535,7	97,8	457,9	121,2	368,5	150,6
15	-	-	631,8	102,1	545,8	125,8	-	-

SRC-S-463								
Tcond	30		40		50		60	
Tevap	Pf	Pa	Pf	Pa	Pf	Pa	Pf	Pa
-16	237,5	85,1	194,2	96,6	-	-	-	-
-15	246,5	84,8	202,8	96,8	-	-	-	-
-10	300,1	84,0	254,6	97,8	208,1	118,8	-	-
-5	368,5	83,8	320,2	99,2	268,0	121,8	-	-
0	451,7	84,3	399,9	101,1	341,1	124,9	273,8	154,6
2	489,1	84,6	435,7	101,9	374,1	126,2	302,7	156,3
5	549,8	85,4	493,7	103,4	427,5	128,3	349,8	159,0
10	-	-	601,6	106,1	527,3	131,9	438,3	163,3
15	-	-	723,6	109,4	640,4	135,8	-	-

SRC-S-503								
Tcond	30		40		50		60	
Tevap	Pf	Pa	Pf	Pa	Pf	Pa	Pf	Pa
-16	261,7	93,8	214,0	106,5	-	-	-	-
-15	271,6	93,5	223,5	106,6	-	-	-	-
-10	330,7	92,6	280,5	107,8	229,3	130,9	-	-
-5	406,0	92,4	352,9	109,3	295,3	134,2	-	-
0	497,7	92,9	440,7	111,4	375,9	137,6	301,7	170,4
2	539,0	93,3	480,2	112,3	412,3	139,1	333,6	172,3
5	605,8	94,1	544,0	113,9	471,1	141,4	385,5	175,2
10	-	-	662,9	116,9	581,0	145,4	483,0	180,0
15	-	-	797,4	120,5	705,7	149,7	-	-



working conditions which require the monitoring of the filter lodgement. See chapter SA-02.

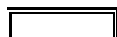

working conditions which require the additional cooling. See chapter SA-11.

SRC-S-553								
Tcond	30		40		50		60	
Tevap	Pf	Pa	Pf	Pa	Pf	Pa	Pf	Pa
-16	279,4	100,1	228,4	113,7	-	-	-	-
-15	289,9	99,8	238,6	113,8	-	-	-	-
-10	353,0	98,9	299,5	115,1	244,8	139,8	-	-
-5	433,5	98,6	376,7	116,7	315,3	143,3	-	-
0	531,4	99,1	470,5	118,9	401,3	147,0	322,1	181,9
2	575,4	99,6	512,6	119,9	440,1	148,5	356,1	183,9
5	646,8	100,5	580,8	121,6	503,0	150,9	411,5	187,0
10	-	-	707,7	124,8	620,3	155,2	515,7	192,2
15	-	-	851,3	128,7	753,4	159,8	-	-

SRC-S-603								
Tcond	30		40		50		60	
Tevap	Pf	Pa	Pf	Pa	Pf	Pa	Pf	Pa
-16	342,8	105,3	298,1	128,6	-	-	-	-
-15	358,4	105,8	312,0	129,4	-	-	-	-
-10	444,3	109,5	389,1	134,1	331,1	164,6	-	-
-5	543,5	115,1	479,6	139,8	413,0	171,6	-	-
0	656,1	122,4	583,5	146,5	508,2	178,6	430,5	219,2
2	704,9	125,9	628,8	149,4	550,1	181,5	468,9	222,4
5	782,2	131,6	700,8	154,1	616,9	185,8	530,6	227,0
10	-	-	831,6	162,7	739,0	193,1	644,1	234,1
15	-	-	975,8	172,3	874,6	200,5	-	-

SRC-S-755								
Tcond	30		40		50		60	
Tevap	Pf	Pa	Pf	Pa	Pf	Pa	Pf	Pa
-16	393,2	124,0	330,2	157,3	-	-	-	-
-15	411,5	124,6	347,6	158,2	-	-	-	-
-10	511,3	127,8	438,6	162,5	352,2	202,2	-	-
-5	629,1	131,8	541,1	166,5	448,4	208,4	-	-
0	770,7	137,2	660,9	170,7	555,5	213,7	468,3	260,6
2	835,3	139,8	715,0	172,6	602,7	215,7	512,1	263,6
5	941,9	144,5	803,8	175,8	679,2	218,8	581,8	267,8
10	-	-	975,8	182,3	825,4	224,2	711,4	274,2
15	-	-	1182,5	190,84	1000	230,419	-	-

SRC-S-785								
Tcond	30		40		50		60	
Tevap	Pf	Pa	Pf	Pa	Pf	Pa	Pf	Pa
-16	474,4	144,2	412,6	176,2	-	-	-	-
-15	496,0	144,9	431,7	177,3	-	-	-	-
-10	614,8	150,0	538,5	183,8	458,3	225,6	-	-
-5	752,1	157,6	663,7	191,6	571,5	236,1	-	-
0	908,0	167,7	807,5	200,7	703,3	244,7	596,7	300,3
2	975,5	172,4	870,2	204,7	761,3	248,6	648,9	304,7
5	1082,4	180,3	968,9	211,1	853,7	254,6	734,2	311,0
10	-	-	1150,8	222,9	1022,7	264,6	891,3	320,7
15	-	-	1360,4	236,0	1210,3	274,8	-	-

SRC-S-885								
Tcond	30		40		50		60	
Tevap	Pf	Pa	Pf	Pa	Pf	Pa	Pf	Pa
-16	535,7	162,8	465,9	198,9	-	-	-	-
-15	560,0	163,6	487,5	200,2	-	-	-	-
-10	694,2	169,4	608,0	207,5	517,5	254,7	-	-
-5	849,3	178,0	749,5	216,3	645,4	265,4	-	-
0	1025,3	189,4	911,9	226,6	794,2	276,3	672,7	339,1
2	1101,6	194,7	982,7	231,2	859,6	280,8	732,7	344,0
5	1222,3	203,6	1095,2	238,4	964,0	287,4	829,1	351,2
10	-	-	1299,5	251,7	1154,8	298,7	1006,5	362,2
15	-	-	1524,9	266,5	1366,7	310,2	-	-

SRC-S-985								
Tcond	30		40		50		60	
Tevap	Pf	Pa	Pf	Pa	Pf	Pa	Pf	Pa
-16	598,1	181,8	520,2	222,1	-	-	-	-
-15	625,3	182,7	544,3	223,5	-	-	-	-
-10	775,1	189,1	678,9	231,7	577,8	284,4	-	-
-5	948,3	198,7	836,8	241,5	720,6	296,3	-	-
0	1144,8	211,4	1018,1	253,0	886,7	308,5	751,1	378,6
2	1229,9	217,4	1097,2	258,1	959,8	313,5	818,1	384,1
5	1364,7	227,3	1222,8	266,2	1076,3	320,9	925,7	392,1
10	-	-	1450,9	281,1	1289,4	333,6	1123,8	404,3
15	-	-	1702,6	297,6	1525,9	346,4	-	-



working conditions which require the monitoring of the filter lodgement. See chapter SA-02.

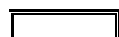

working conditions which require the additional cooling. See chapter SA-11.

9.4 Performance data with R404A/R507refrigerant

SRC-XS-40/SRC-S-113								
Tcond	30		40		50		53	
Tevap	PF	Pa	PF	Pa	PF	Pa	PF	Pa
-25	41,7	22,2	32,4	27,9	-	-	-	-
-20	54,8	22,9	44,0	28,8	-	-	-	-
-15	70,7	23,7	57,9	29,6	44,9	38,4	40,9	41,5
-10	89,2	24,6	74,1	30,6	56,5	39,2	50,7	42,3
-5	110,4	25,5	92,7	31,6	70,1	40,0	62,4	43,0
0	134,4	26,5	113,7	32,6	85,8	40,9	76,0	43,8

SRC-XS-50/SRC-S-133								
Tcond	30		40		50		53	
Tevap	PF	Pa	PF	Pa	PF	Pa	PF	Pa
-25	53,0	28,0	41,2	35,1	-	-	-	-
-20	69,7	28,9	55,9	36,2	-	-	-	-
-15	89,8	29,8	73,6	37,3	57,0	48,3	51,9	52,3
-10	113,4	30,9	94,2	38,5	71,8	49,3	64,4	53,2
-5	140,4	32,1	117,8	39,7	89,2	50,4	79,3	54,2
0	170,9	33,4	144,5	41,1	109,1	51,5	96,7	55,2

SRC-XS-60/SRC-S-163								
Tcond	30		40		50		53	
Tevap	PF	Pa	PF	Pa	PF	Pa	PF	Pa
-25	63,6	32,8	48,3	40,5	-	-	-	-
-20	80,1	32,8	63,9	40,8	-	-	-	-
-15	100,1	33,0	82,4	41,1	63,1	52,5	56,8	56,6
-10	123,6	33,3	104,0	41,6	80,4	53,3	72,4	57,5
-5	150,7	33,9	128,7	42,1	100,3	54,0	90,4	58,3
0	181,5	34,7	156,6	42,7	122,8	54,6	110,9	59,0

SRC-S-183								
Tcond	30		40		50		53	
Tevap	PF	Pa	PF	Pa	PF	Pa	PF	Pa
-25	73,8	38,0	56,1	46,9	-	-	-	-
-20	93,0	38,0	74,1	47,3	-	-	-	-
-15	116,2	38,2	95,7	47,7	73,2	60,9	66,0	65,6
-10	143,5	38,7	120,8	48,2	93,3	61,8	84,1	66,7
-5	175,0	39,4	149,5	48,8	116,4	62,6	105,0	67,6
0	210,7	40,3	181,8	49,5	142,6	63,3	128,8	68,4

SRC-S-213								
Tcond	30		40		50		53	
Tevap	PF	Pa	PF	Pa	PF	Pa	PF	Pa
-25	85,3	43,5	64,8	53,7	-	-	-	-
-20	107,5	43,5	85,7	54,1	-	-	-	-
-15	134,3	43,7	110,6	54,6	84,6	69,7	76,3	75,1
-10	165,9	44,3	139,6	55,2	107,9	70,7	97,2	76,3
-5	202,3	45,0	172,8	55,9	134,6	71,7	121,4	77,4
0	243,6	46,1	210,1	56,7	164,9	72,5	148,9	78,3

SRC-S-253/255								
Tcond	30		40		50		53	
Tevap	PF	Pa	PF	Pa	PF	Pa	PF	Pa
-25	104,8	52,5	79,6	64,8	-	-	-	-
-20	132,0	52,5	105,3	65,3	-	-	-	-
-15	165,0	52,8	135,9	65,9	104,0	84,2	93,7	90,7
-10	203,8	53,4	171,5	66,6	132,5	85,4	119,4	92,1
-5	248,5	54,4	212,2	67,5	165,3	86,5	149,1	93,4
0	299,2	55,6	258,0	68,4	202,5	87,5	182,9	94,5

SRC-S-285 (*)								
Tcond	30		40		50		53	
Tevap	PF	Pa	PF	Pa	PF	Pa	PF	Pa
-25	116,6	58,3	88,6	72,0	-	-	-	-
-20	146,9	58,3	117,1	72,5	-	-	-	-
-15	183,6	58,6	151,2	73,2	115,7	93,4	104,3	100,6
-10	226,8	59,3	190,8	74,0	147,4	94,8	132,8	102,2
-5	276,5	60,3	236,1	74,9	184,0	96,0	165,9	103,6
0	332,9	61,7	287,2	75,9	225,3	97,1	203,5	104,9

(*) dati non definitivi;

SRC-S-303/305								
Tcond	30		40		50		53	
Tevap	PF	Pa	PF	Pa	PF	Pa	PF	Pa
-25	126,2	63,2	95,9	78,1	-	-	-	-
-20	159,0	63,2	126,8	78,6	-	-	-	-
-15	198,7	63,6	163,7	79,4	125,2	101,3	112,9	109,2
-10	245,4	64,3	206,6	80,2	159,6	102,8	143,8	110,9
-5	299,3	65,5	255,6	81,2	199,1	104,1	179,6	112,4
0	360,3	67,0	310,8	82,4	243,9	105,4	220,3	113,8

SRC-S-353								
Tcond	30		40		50		53	
Tevap	PF	Pa	PF	Pa	PF	Pa	PF	Pa
-25	150,5	74,4	114,4	91,8	-	-	-	-
-20	189,6	74,3	151,2	92,5	-	-	-	-
-15	236,9	74,8	195,2	93,3	149,3	119,2	134,6	128,4
-10	292,7	75,6	246,3	94,3	190,3	120,9	171,5	130,4
-5	356,9	77,0	304,8	95,5	237,5	122,5	214,1	132,2
0	429,7	78,7	370,7	96,8	290,9	123,9	262,7	133,8

SRC-S-413								
Tcond	30		40		50		53	
Tevap	PF	Pa	PF	Pa	PF	Pa	PF	Pa
-25	168,2	82,4	127,8	101,7	-	-	-	-
-20	211,8	82,3	169,0	102,4	-	-	-	-
-15	264,7	82,8	218,1	103,3	166,8	132,0	150,4	142,1
-10	327,0	83,8	275,2	104,5	212,7	133,9	191,6	144,4
-5	398,8	85,2	340,5	105,8	265,3	135,6	239,3	146,4
0	480,1	87,2	414,2	107,2	325,0	137,2	293,5	148,2

SRC-S-463								
Tcond	30		40		50		53	
Tevap	PF	Pa	PF	Pa	PF	Pa	PF	Pa
-25	179,9	88,5	141,8	107,8	-	-	-	-
-20	225,0	88,9	186,8	109,1	-	-	-	-
-15	283,4	90,3	242,2	111,0	195,7	143,4	180,7	155,2
-10	355,1	92,6	308,0	113,6	249,9	144,5	230,3	155,7
-5	440,1	96,0	384,1	116,8	311,4	146,1	286,4	156,4
0	538,4	100,5	470,5	120,9	380,4	148,0	349,0	157,4

SRC-S-503								
Tcond	30		40		50		53	
Tevap	PF	Pa	PF	Pa	PF	Pa	PF	Pa
-25	198,3	97,5	156,2	118,7	-	-	-	-
-20	248,0	98,0	205,9	120,2	-	-	-	-
-15	312,3	99,5	266,9	122,3	215,7	158,0	199,2	171,1
-10	391,3	102,1	339,4	125,1	275,4	159,3	253,8	171,5
-5	485,0	105,8	423,2	128,7	343,2	161,0	315,6	172,3
0	593,3	110,8	518,5	133,2	419,2	163,1	384,6	173,5

SRC-S-553								
Tcond	30		40		50		53	
Tevap	PF	Pa	PF	Pa	PF	Pa	PF	Pa
-25	211,7	104,1	166,8	126,8	-	-	-	-
-20	264,8	104,6	219,8	128,4	-	-	-	-
-15	333,5	106,2	285,0	130,6	230,3	168,7	212,6	182,6
-10	417,8	109,0	362,3	133,6	294,0	170,0	270,9	183,1
-5	517,8	113,0	451,8	137,5	366,4	171,9	336,9	183,9
0	633,4	118,3	553,6	142,2	447,5	174,2	410,6	185,2

SRC-S-603								
Tcond	30		40		50		53	
Tevap	PF	Pa	PF	Pa	PF	Pa	PF	Pa
-25	277,8	121,6	231,6	150,4	-	-	-	-
-20	347,0	125,4	297,8	154,1	-	-	-	-
-15	428,3	130,2	373,6	158,5	307,9	195,2	286,3	207,8
-10	521,6	135,8	458,7	163,6	383,7	202,4	359,0	216,2
-5	626,7	142,3	553,1	169,3	466,1	210,0	437,6	224,9
0	743,7	149,7	656,8	175,7	555,2	218,1	522,1	234,1

SRC-S-785								
Tc	30		40		50		53	
Te	Pf	Pa	Pf	Pa	Pf	Pa	Pf	Pa
-25	384,4	166,7	320,5	206,1	-	-	-	-
-20	480,2	171,9	412,2	211,2	-	-	-	-
-15	592,7	178,3	517,0	217,2	426,1	267,4	396,2	284,7
-10	721,8	186,0	634,8	224,1	530,9	277,2	496,8	296,2
-5	867,3	195,0	765,5	232,0	645,1	287,7	605,6	308,2
0	1029,1	205,1	908,9	240,7	768,4	298,8	722,5	320,7

SRC-S-885								
Tc	30		40		50		53	
Te	Pf	Pa	Pf	Pa	Pf	Pa	Pf	Pa
-25	434,1	188,2	361,9	232,7	-	-	-	-
-20	542,3	194,1	465,4	238,4	-	-	-	-
-15	669,3	201,4	583,7	245,2	481,2	301,9	447,4	321,5
-10	815,0	210,1	716,8	253,1	599,5	313,1	560,9	334,4
-5	979,4	220,1	864,3	261,9	728,4	324,9	683,8	348,0
0	1162,1	231,6	1026,3	271,8	867,6	337,4	815,8	362,1

SRC-S-985								
Tc	30		40		50		53	
Te	Pf	Pa	Pf	Pa	Pf	Pa	Pf	Pa
-25	484,7	210,1	404,1	259,9	-	-	-	-
-20	605,5	216,7	519,6	266,2	-	-	-	-
-15	747,3	224,8	651,8	273,8	537,3	337,1	499,5	358,9
-10	910,0	234,5	800,3	282,5	669,4	349,5	626,3	373,4
-5	1093,5	245,8	965,1	292,5	813,3	362,8	763,5	388,5
0	1297,5	258,5	1145,9	303,5	968,7	376,8	910,9	404,3

SRC-XS and SRC-S series compressors

Application range

(SA-10-03-E)

10.	APPLICATION RANGE	2
10.1	GENERAL	2
10.2	APPLICATION RANGE WITH THE R22 REFRIGERANT	3
10.3	APPLICATION RANGE WITH THE R134A REFRIGERANT	4
10.4	APPLICATION RANGE WITH THE R407C REFRIGERANT	5
10.5	APPLICATION RANGE WITH EITHER R404A OR R507 REFRIGERANTS	6

10. Application range

10.1 General

The normal admissible operating conditions for the SRC-XS and SRC-S series compressors, with changes in evaporation and condensing temperature, are defined by a polygon, as highlighted in picture 10-A.

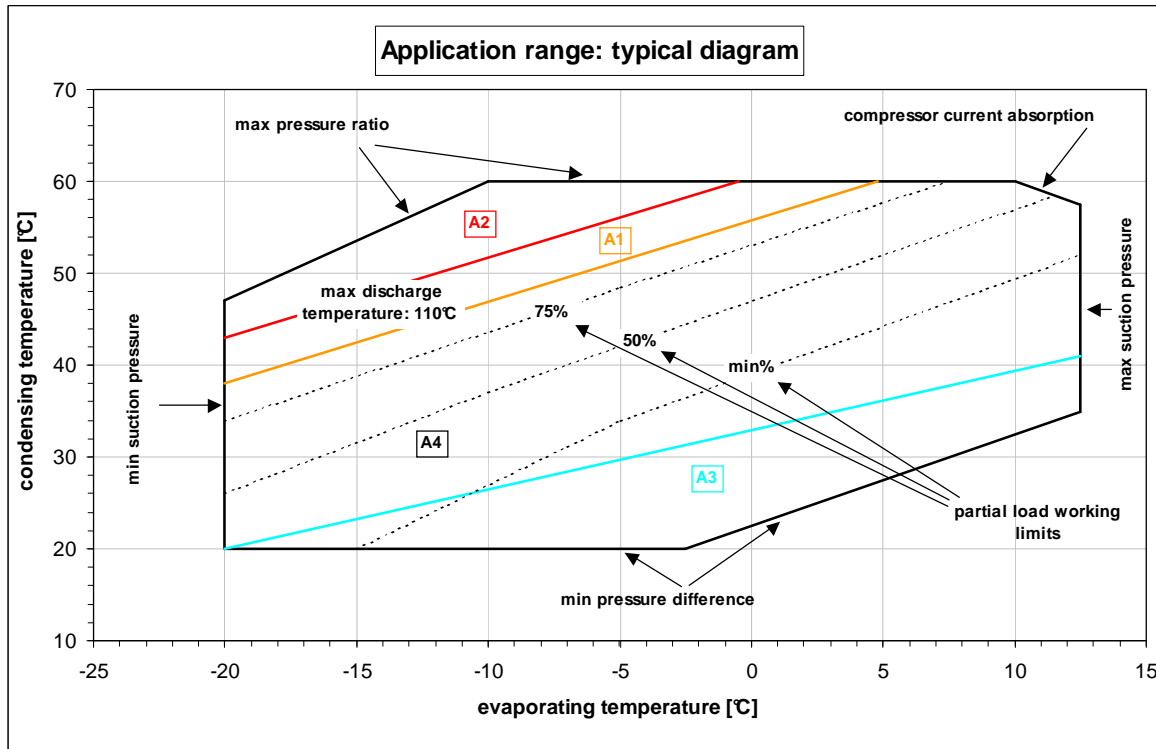

Picture 10-A: typical application range;

The entire field of operation of the compressor is divided into four areas, featuring special precautions that must be adopted so as to ensure correct operation; specifically:

- Area A1: area in which the correct operation of the compressor requires additional cooling by the injection of liquid (refrigerant) or cooling of the oil in an external circuit (air-oil, water-oil and refrigerant-oil heat exchangers), see chapter SA-11: “Additional cooling”;
- Area A2: area in which additional cooling must be provided only by cooling the oil. Use air-oil or water-oil exchangers (the injection of liquid into the compressor is not allowed), see chapter SA-11: “Additional cooling”;
- Area A3: area in which the status of the oil filter needs to be monitored: the pressure drop allowed across the filter must be less than 1.5 bar; if the pressure drop across the filter is greater than 1.5 bar, the compressor must be stopped and the filter replaced. When the filter has been replaced, check the condition of the new filter after around 200-300 hours of operation. The pressure drop across a clean filter is less than 0.8 bar, see chapter SA-02: “Lubrication”;
- Area A4: area of standard compressor operation;

In addition to the above given areas, the diagram gives also, as dotted lines, the working limits on partial load: 75%, 50% and min%. For each partial load, these lines limit the maximum possible condensation temperature in relation to the evaporation temperature.

The following paragraphs describe the operating limits for the different refrigerant fluids that can be used with the SRC-XS and SRC-S compressors, depending on whether the ECONOMIZER circuit is featured or not. All the operating limits refer to a suction vapour superheat of 10K.

10.2 Application range with the R22 refrigerant

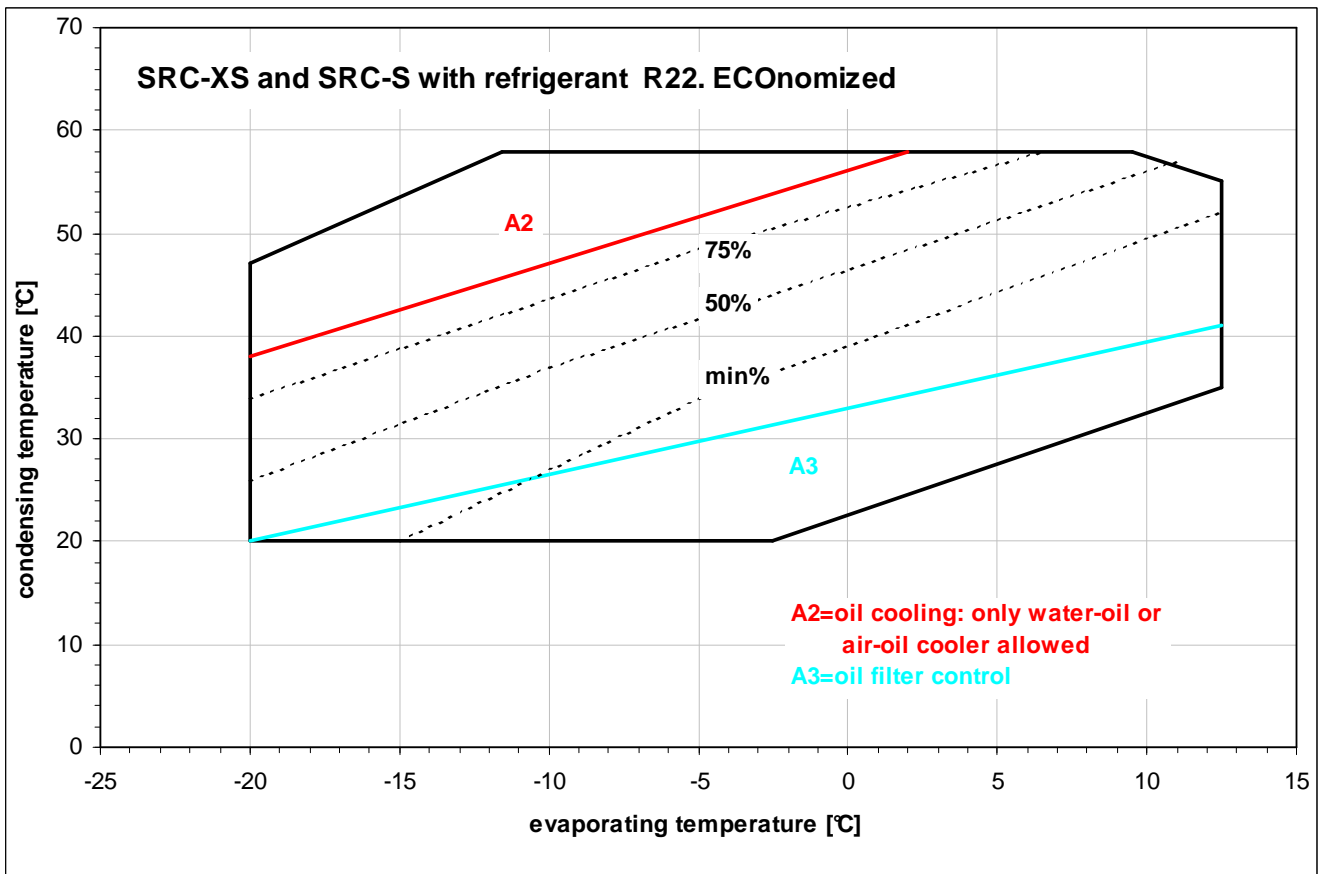
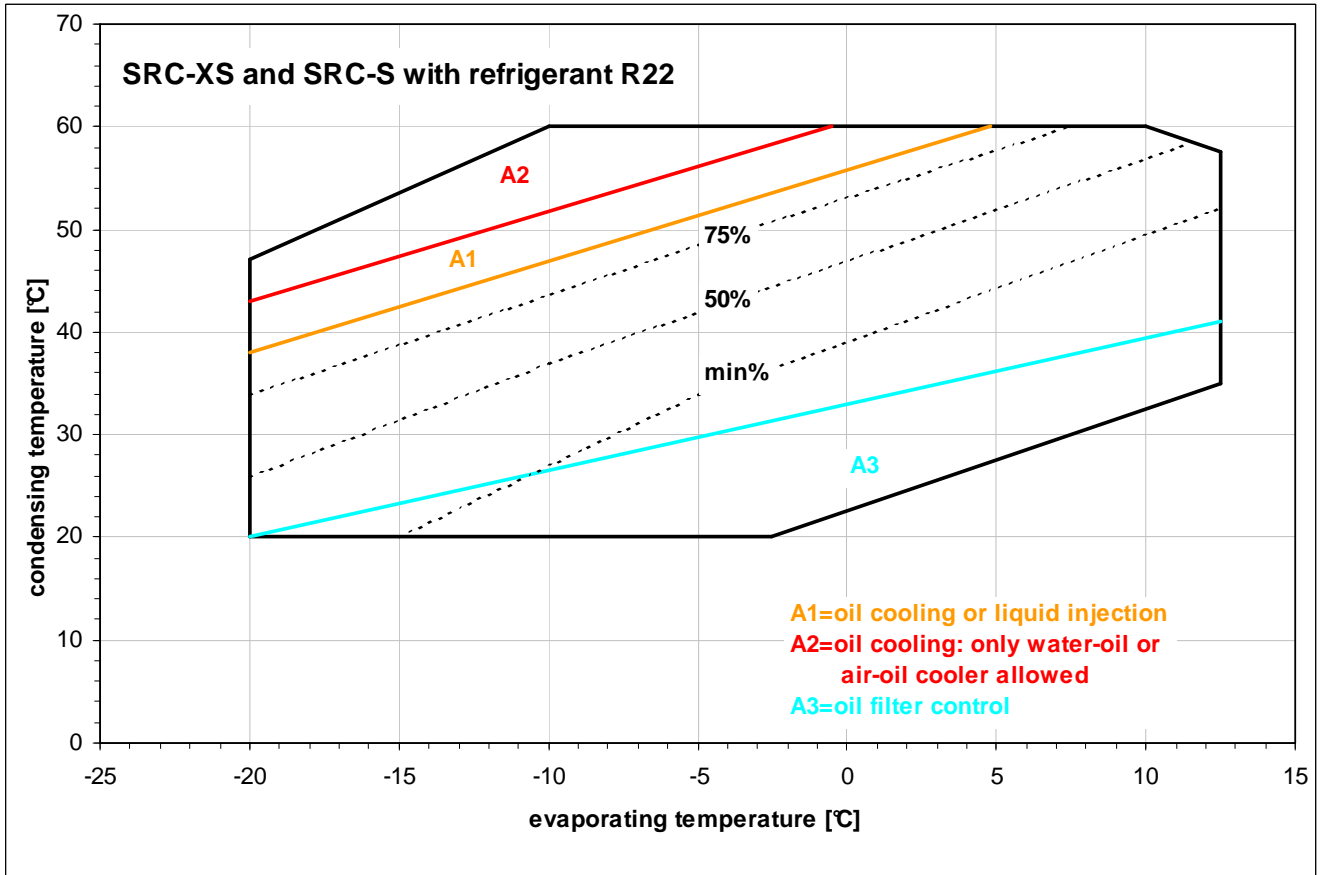

10.3 Application range with the R134a refrigerant

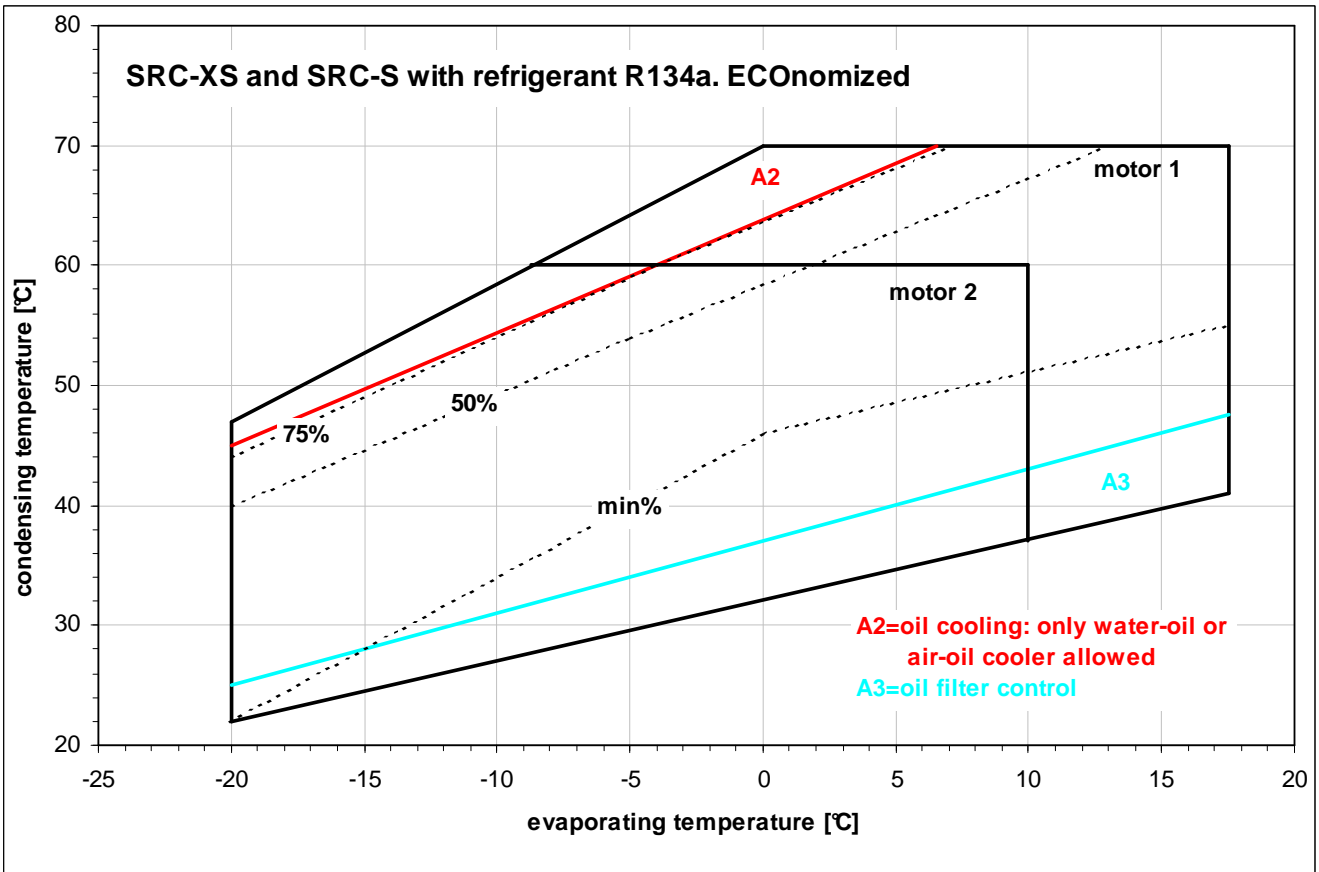
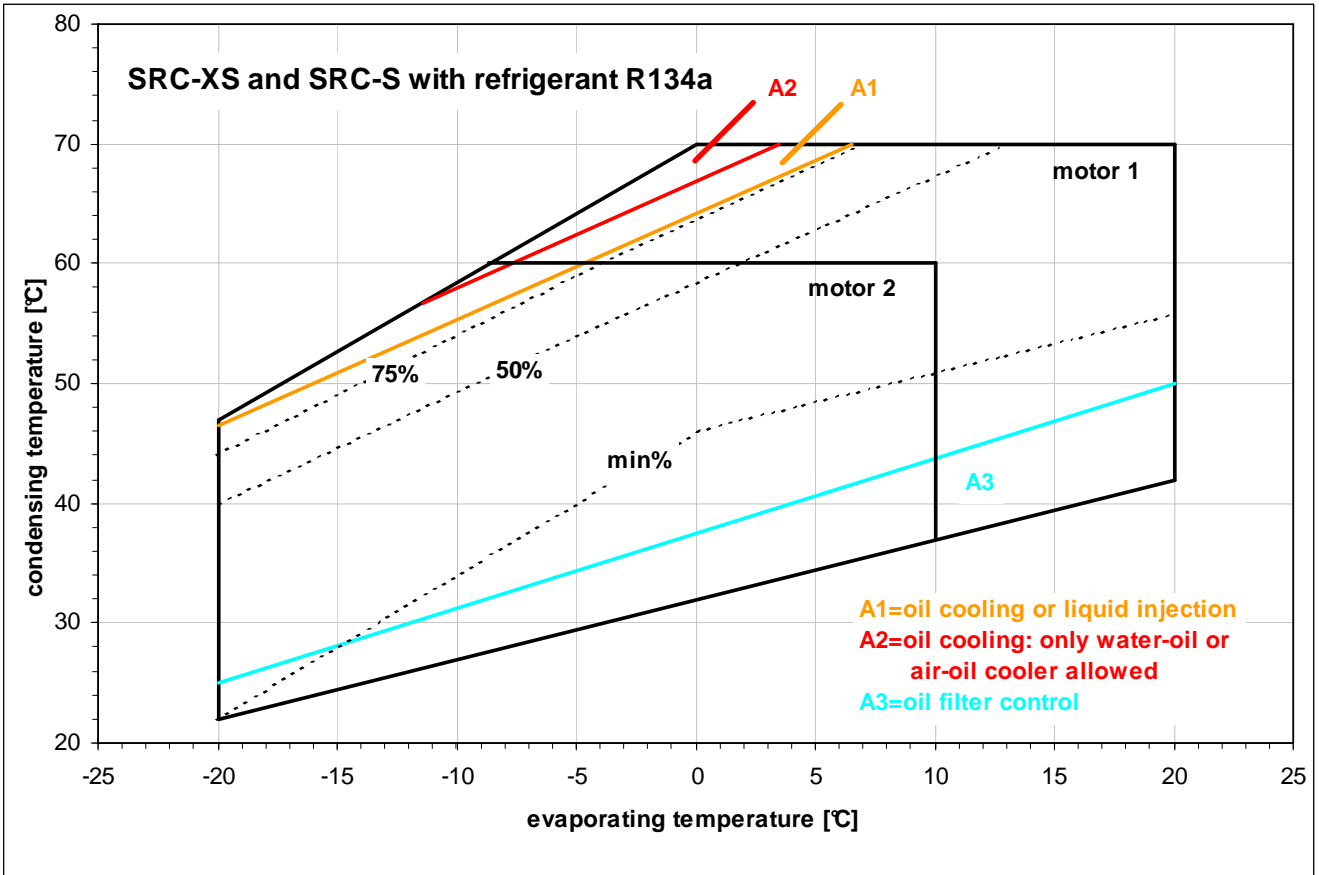

10.4 Application range with the R407C refrigerant

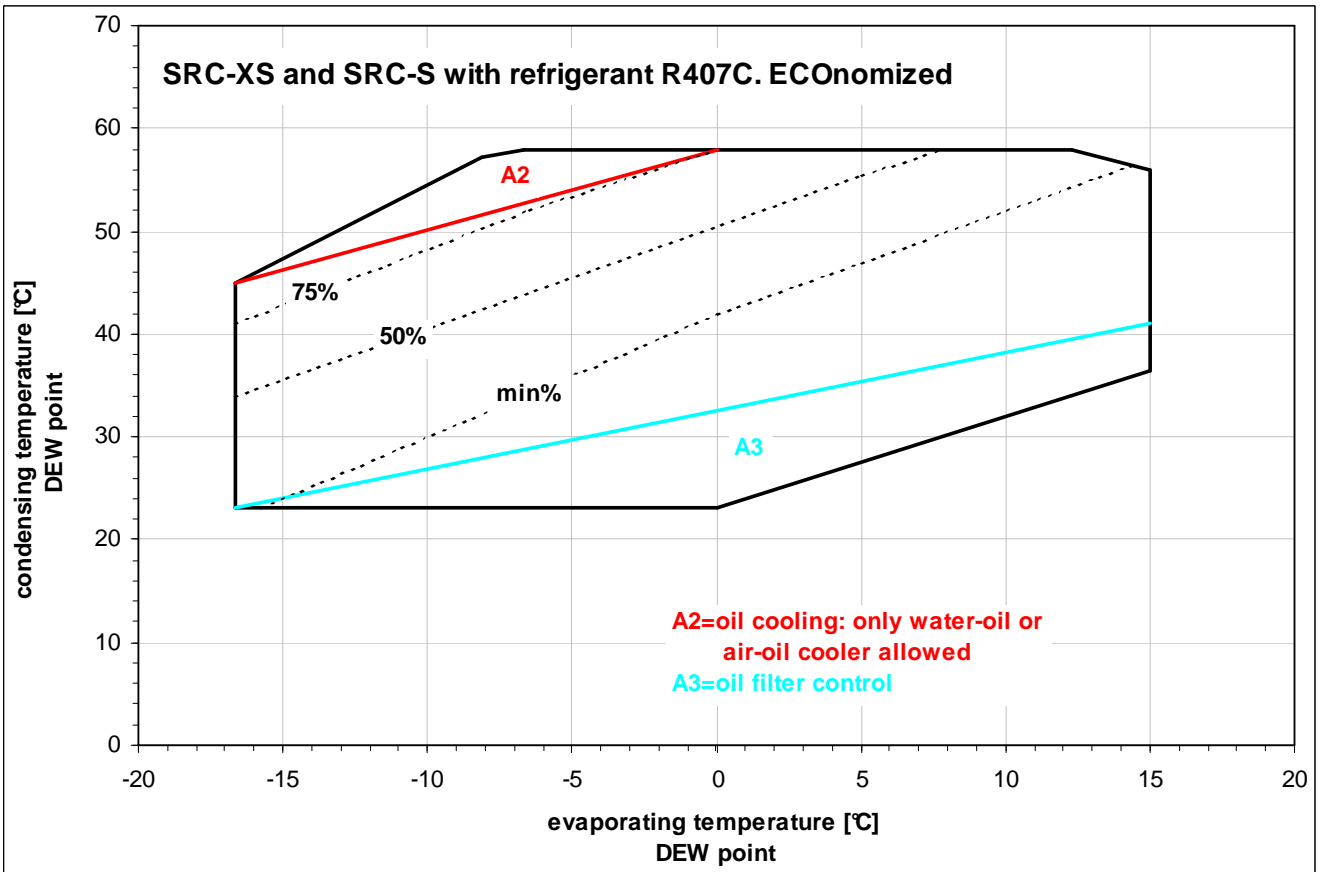
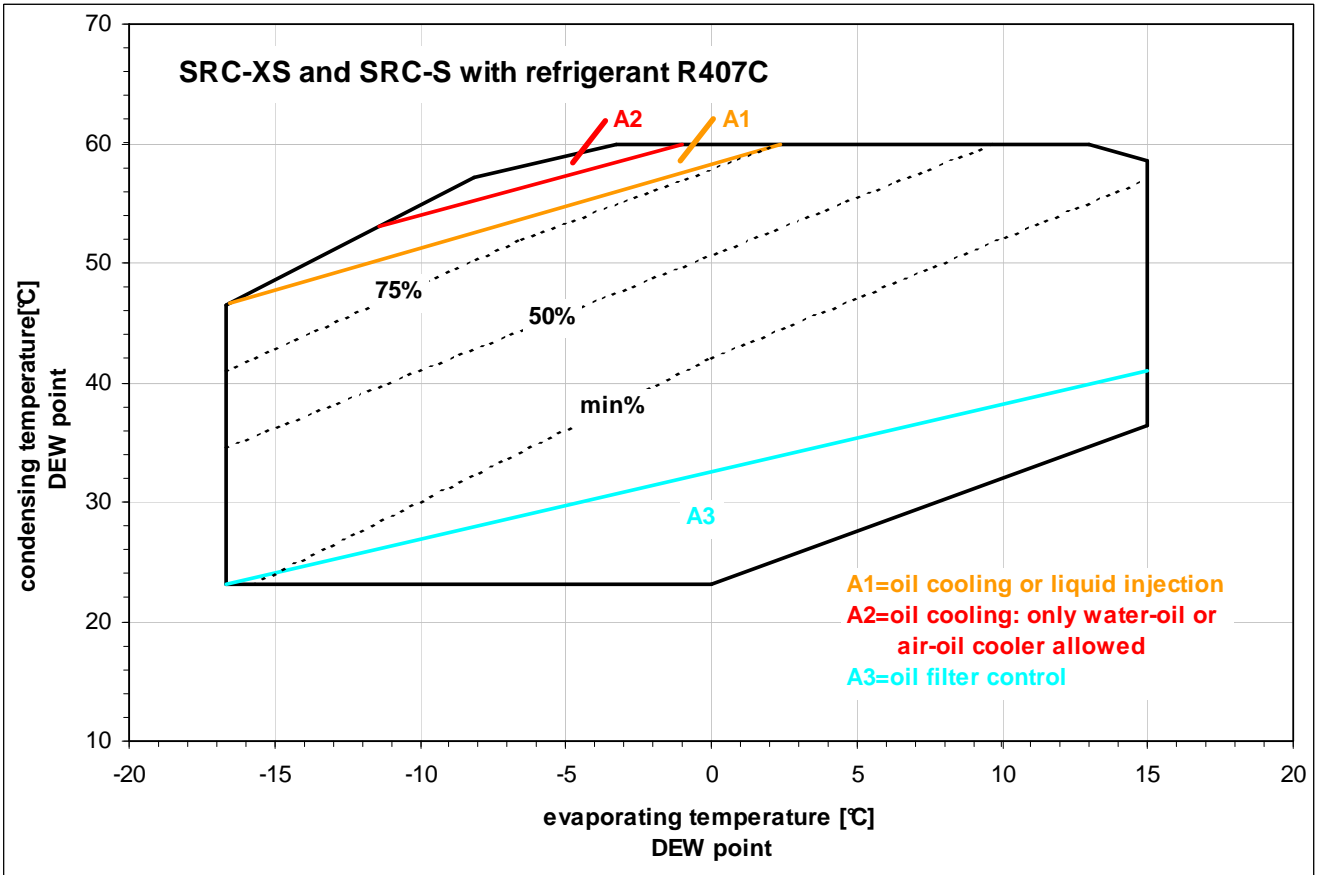

10.5 Application range with either R404A or R507 refrigerants

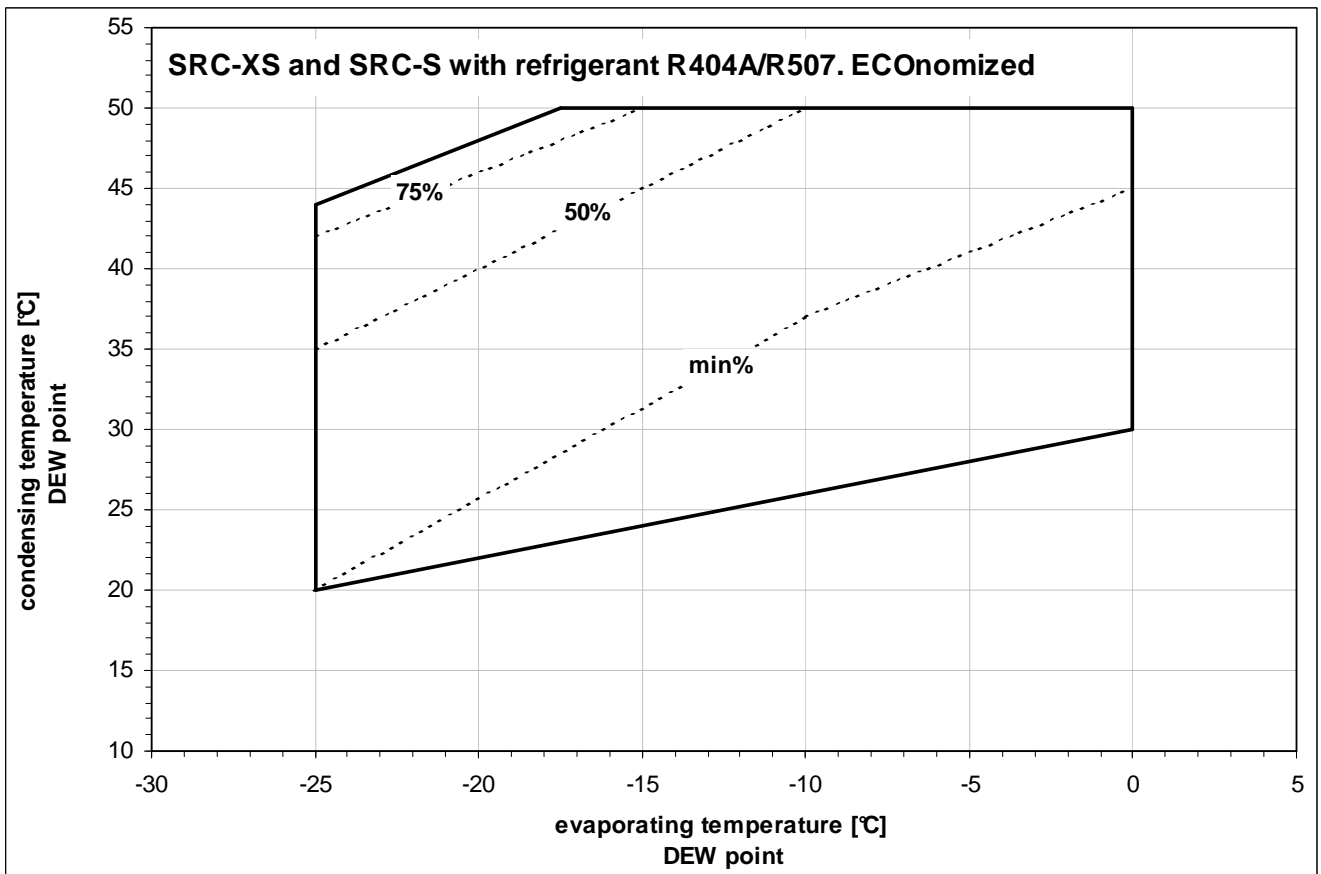
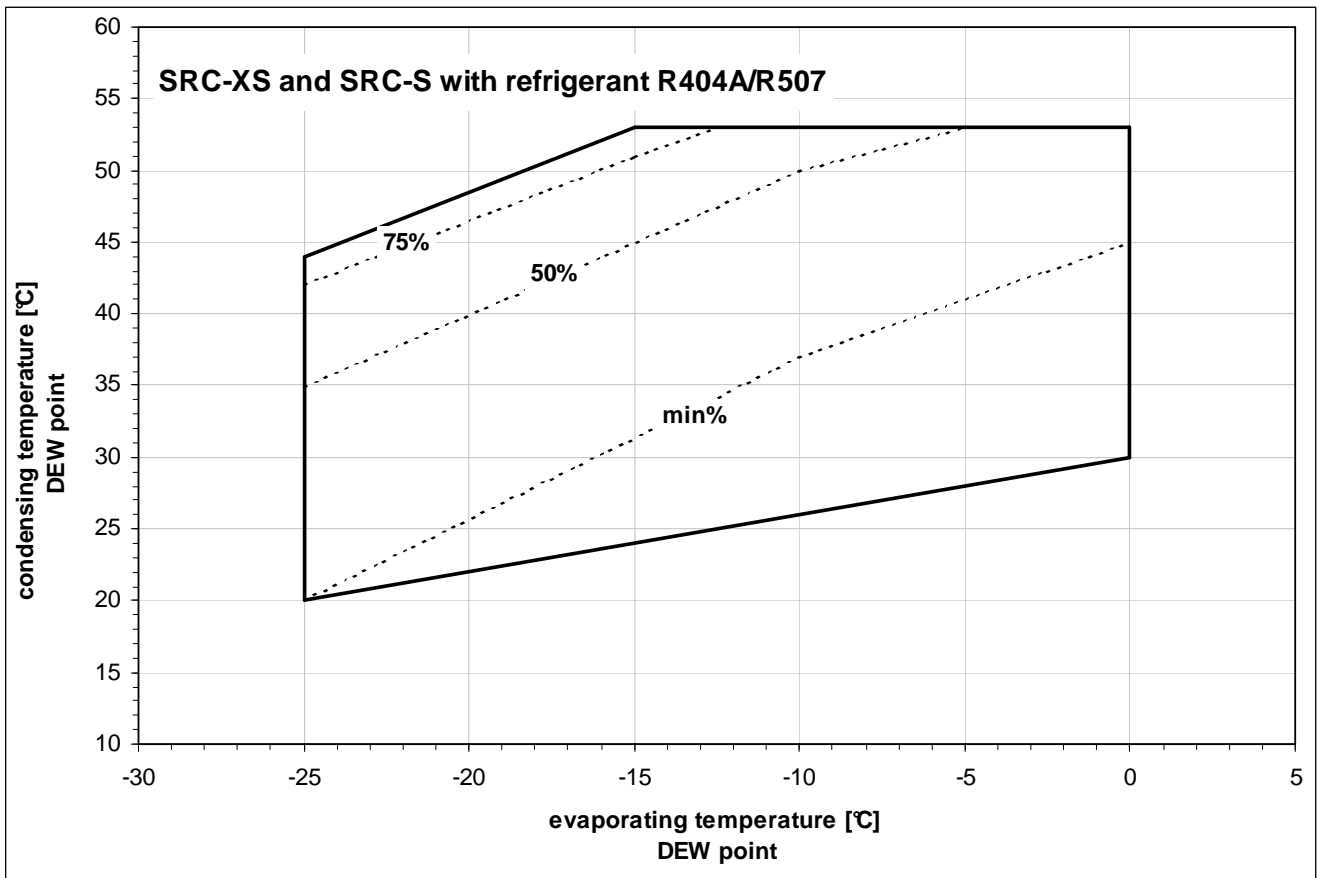

SRC-XS and SRC-S compressors series
Additional cooling
(SA-11-05-E)

11	ADDITIONAL COOLING	2
11.1	ADMISSIBLE COMPRESSOR DISCHARGE TEMPERATURE	2
11.2	EVALUATING THE ADDITIONAL COOLING CAPACITY	3
11.3	INJECTION OF LIQUID BY THERMOSTATIC EXPANSION VALVE	4
11.4	OIL COOLING VIA EXTERNAL HEAT EXCHANGER	7
11.5	POSITION OF THE OIL INLET-OUTLET CONNECTIONS.	10

11 ADDITIONAL COOLING

11.1 Admissible compressor discharge temperature

The value of the discharge temperature is determined by the following factors:

- ✓ power input of the compressor and any part-load conditions, which determine a drop in the cooling capacity of the electric motor;
- ✓ actual cycle working compression ratio;
- ✓ superheating of the refrigerant fluid on the suction side;
- ✓ characteristics of the refrigerant gas, such as the thermal capacity;
- ✓ characteristics of the oil mixed with the refrigerant.

An excessive discharge temperature can cause:

- ✓ the carbonisation and permanent alteration of the oil;
- ✓ a reduction in the oil cinematic viscosity, with a consequent drop in the lubrication capacity and reduction in the volumetric efficiency of the compressor;

Excessive cooling of the oil, on the other hand, may cause, as well as a high pressure drop in the oil circuit, the excessive dilution of the oil by the refrigerant, and consequently:

- ✓ an alteration in the flow of lubricant inside the compressor;
- ✓ a reduction in the lubricating properties;
- ✓ the bypass of refrigerant fluid to the suction side (through the oil circuit), which has undergone the compression process but will not produce the cooling effect.

The maximum admissible discharge temperature is **110 °C** while, when the compressor is off, the minimum temperature of the oil before starting is **40°C**.

Below is described how to evaluate the additional cooling capacity when the oil needs to be cooled, and the possible ways to provide it. As regards the heating of the oil, on the other hand, see paragraph 2-6: 'Oil heater' in chapter SA-02: "Lubrication".

11.2 Evaluating the additional cooling capacity

When the discharge temperature exceeds 110°C, an additional cooling system is required. The additional cooling capacity required to perform such cooling can be calculated by multiplying the mass flow in the evaporator by the difference between the enthalpy at the discharge without additional cooling and the enthalpy at the discharge pressure when the temperature is 110°C (the enthalpy values should be read on the refrigerant chart).

When calculating the required cooling capacity, the most critical normal operating conditions should be considered (minimum evaporation temperature, maximum condensing temperature, maximum superheat).

Alternatively, the calculation can be performed automatically using the RefComp LEONARDO selection program.

As a result, depending on the additional cooling capacity to be provided, there are two possible methods to limit the compressor discharge temperature:

- ✓ Cooling by injection of refrigerant (liquid) onto the rotors. It is taken from the condenser outlet and subsequently expanded;
- ✓ Cooling of the oil in a circuit external to the compressor. It can be used either an oil-air, or an oil-water, or an oil-refrigerant heat exchanger.

The following pages describe the two above-mentioned methods of cooling.

11.3 Injection of liquid by thermostatic expansion valve

A relatively simple and economical system for additional cooling consists in the injection of refrigerant (saturated liquid) at intermediate pressure onto the rotors, as seen in the diagram of picture 11.A¹. The liquid is injected through the economizer port and allows the operating limits to be extended, see chapter SA-10: *Application range*.

When the required additional cooling capacity exceeds a certain percentage of the compressor cooling capacity, the use of this method would entail an excessive quantity of refrigerant and bring about its dilution in the oil, with a consequent loss in the oil lubricating properties, as well as an excessive overloading of the motor. In this situation, the oil should be cooled in an external circuit with a heat exchanger, see the following paragraph. The operating limits shown in chapter SA-10 highlight the normal operating conditions in which cooling by injection is admissible, and the conditions where an external oil cooler is required.

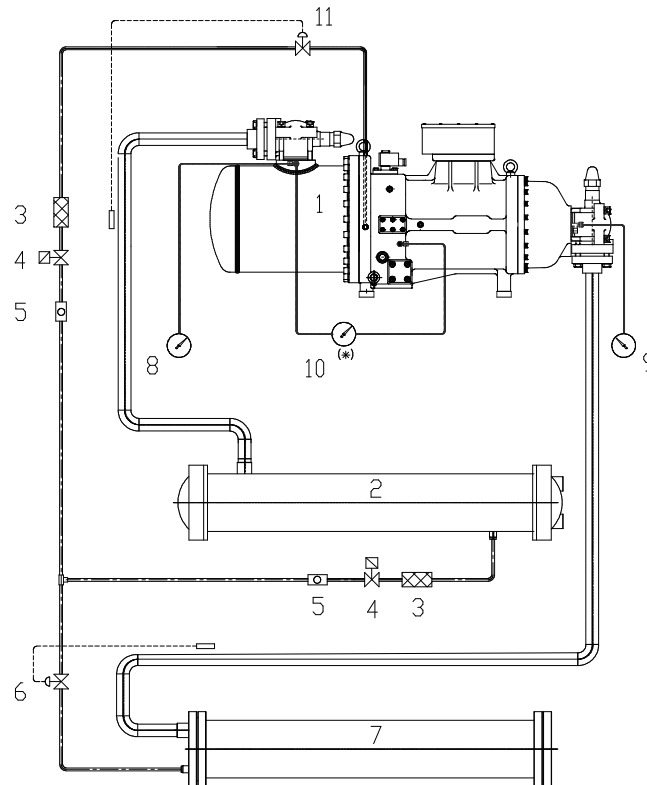

- | | |
|--|--|
| 1 Compressor; | 7 Evaporator; |
| 2 Condenser; | 8 HP pressure gauge (high pressure); |
| 3 Filter; | 9 LP pressure gauge (Low pressure); |
| 4 Solenoid valve; | 10 Differential pressure gauge on the oil filter; |
| 5 Sight glass; | 11 Thermostatic injection valve. |
| 6 Thermostatic expansion valve; | |

Picture 11. A: injection of refrigerant (saturated liquid) via thermostatic expansion valve;

¹ This is simply a schematic drawing; refer to the dimensional drawing for each individual compressor to identify the actual position of the liquid injection port and the high and low pressure connections.

To inject the refrigerant into the compressor, an expansion device must be installed; this may be:

- ✓ a thermostatic expansion valve;
- ✓ a calibrated nozzle;
- ✓ a capillary tube.

If a thermostatic valve is used, the expansion can be controlled accurately. In this case, the quantity of refrigerant injected varies according to the actual temperature measured at the discharge side of the compressor. The thermostatic valve should be set to be activated at discharge temperatures of 100-110°C (manufacturers such as Danfoss, Alco and Sporlan provide such products).

	<p>Note:</p> <ul style="list-style-type: none">✓ for the correct sizing of the thermostatic valve according to the specific application, contact your valve supplier;✓ the use of liquid injection is not recommended when the required additional cooling capacity reaches values of around 10% of the cooling capacity of the compressor;✓ the use of liquid injection together with the ECONOMIZER circuit is strongly not recommended.
---	---

The thermostatic valve bulb must be positioned on the discharge line around 10-20 cm from the discharge shut-off valve; it must be thermally insulated so as to not be affected by the outside temperature, and the contact with the discharge pipe must be improved by using conductive paste. Attach the bulb securely.

Make sure only saturated liquid or sub-cooled liquid is tapped from the line. Once the injection circuit has been constructed, check that there are no dangerous vibrations in the section of pipe that runs from the valve to the point of injection.

To prevent the migration of oil and protect the components against liquid-oil slugging, the injection pipe must initially run vertically, starting from the point of injection, see the picture 11.B¹.

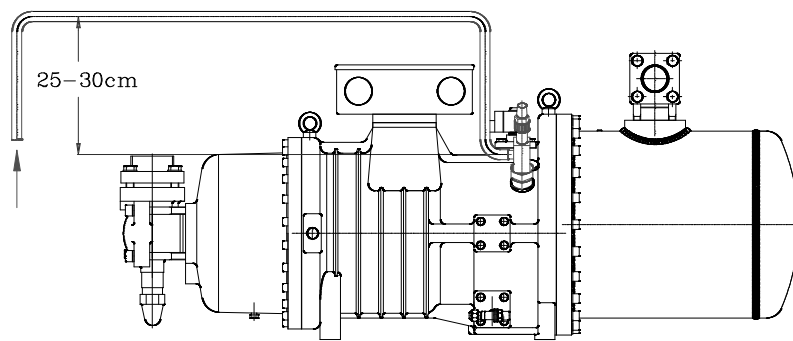

Picture 11. B: layout of the liquid injection line;

The valve should not be oversized, so as to avoid the injection of an excessive quantity of liquid. When sizing, the injection pressure must be considered, intermediate between the evaporation and condensing pressure. This can be determined using the LEONARDO selection program.

Together with the expansion device, the injection circuit must be fitted with a solenoid valve, a thermostat (or equivalent device) positioned on the discharge, a sight glass and a fine mesh filter (max 25 µm) to avoid the injection of metallic particles onto the rotors that may affect the correct operation and the life of the compressor.

¹ This is just a schematic drawing: please refer to the specific compressor dimensional drawing in order to locate the actual position for the liquid injection port.

The thermostat on the discharge line will activate the injection circuit when the discharge temperature exceeds the value of 110°C, while it will be de-activated when the discharge temperature drops below 100-105°C.

The compressor should have an injection fitting (special accessory available upon request); the diameter of the injection pipe is determined according to Table A below.

SRC-XS	40	50	60
Diametro [mm]	16		

SRC-S	113	133	163	183	213	253	255	285	303	305	353	413	463	503	553	603	755	785	885	985
D [mm]	16										22		42		28					

Table A: injection pipe diameter;

For the injection of the liquid, use the following kit, according to the model of the compressor:

- models SRC-S-113/133/163/183/213: kit n° 303134

Components: liquid injection fitting	n° 517740
Teflon gasket	n° 592360
aluminium washer	n° 613840
elbow fitting	n° 614450

- models SRC-XS-40/50/60 and SRC-S-253/255/285/303/305: kit n° 303084

Components: liquid injection fitting	n° 517740
Teflon gasket	n° 592360
aluminium washer	n° 613840
straight fitting	n° 614120

- models SRC-S-353/413/463: kit n° 303148

Components: flange attachment	n° 519085
oval valve flange gasket	n° 591030
Teflon gasket	n° 592360
straight fitting	n° 614090

- models SRC-S-503/553/603: kit n° 303320

Components: pipe coupling	n° 519192
coupling seal flange	n° 519193
coupling closing plate	n° 519194
valve gasket	n° 590790
screw 10.9 M12x50	n° 614510

- models SRC-S-755: kit n° 303157

Components: pipe coupling	n° 511620
oval valve flange gasket	n° 591030
Teflon gasket	n° 591090
Rotalock connection	n° 614370

- models SRC-S-785/885/985 : kit n° 303649

Components: pipe coupling	n° 511620
oval valve flange gasket	n° 591030
Teflon gasket	n° 591020
Rotalock connection	n° 614370

11.4 Oil cooling via external heat exchanger

In comparison with the previous cooling method this one allows a further extension of the application limits of the compressor (see chapter EA-10: 'Application limits') and a more efficient operation. In fact, cooling improves the volumetric and isentropic efficiency of the compression, thus increasing the coefficient of performance of the refrigerating cycle.

For this purpose, the compressor has special oil outlet and inlet fittings (on the internal oil circuit) for connection to the external cooling circuit, see paragraph 11.5. The diameter of the pipes in the circuit is 16 mm for all models in the SRC-XS and SRC-S series.

Using an external circuit increases the compressor oil requirement. In this case, the oil charge in the compressor must be suitably increased according to the type of cooling circuit used. Specifically you must consider:

$$\begin{aligned}
 \text{TOTAL OIL CHARGE} = & \quad \text{COMPRESSOR CHARGE} \\
 & + \text{HEAT EXCHANGER CHARGE} \\
 & + \text{VOLUME OF OIL PIPES} \\
 & + 1\% \text{ OF REFRIGERANT CHARGE}
 \end{aligned}$$



Warning!

the pressure drop in the external oil cooling circuit must not exceed 0.5 bar.

- Air cooled oil cooler**

The oil cooler (finned coil) must be installed as near as possible to the compressor, so that the pressure drop in the circuit does not exceed 0.5 bar in normal conditions. The cooling system with fans must be controlled by a temperature sensor positioned on the compressor discharge line, set at **110°C**; the control logic may be ON-OFF or variable speed.

To ensure the rapid heating of the oil when starting (so as to reduce the high pressure drop with cold oil), the cooler should be heated during standstill periods, or the cooler can be bypassed using a modulating 3 way valve until the discharge temperature reaches **100°C**. This is especially recommended when the temperature of the cooler, during standstill periods, may drop below 40°C, or when the volume of oil in the cooler and in the pipes exceeds 25 dm³

- **Water cooled oil cooler**

The oil-water heat exchanger can be supplied with condensed water or chilled water. The water supply can be modulated by a two-way valve with the temperature sensor on the compressor discharge pipe (set at **110°C**) or alternatively, as highlighted in picture 11-C¹, a modulating three-way valve can be used, with the temperature sensor positioned on the oil pipe leaving the compressor.

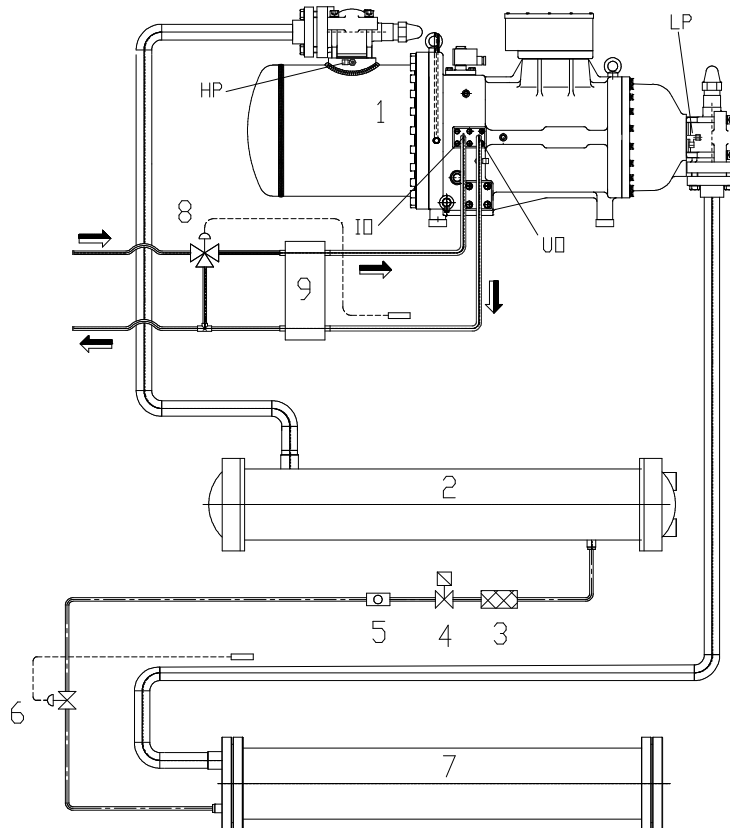

- | | |
|------------------------------|--|
| 1 Compressor; | 7 Evaporator; |
| 2 Condenser; | 8 Modulating 3-way water valve; |
| 3 Filter; | 9 Oil/water heat exchanger; |
| 4 Solenoid valve; | IO oil inlet; |
| 5 Sight glass; | UO oil outlet; |
| 6 Thermostatic valve; | |

Picture 11-C: oil cooling with oil/water heat exchanger;

¹ This is simply a schematic drawing; refer to the drawings of each compressor shown in the paragraph 11-5 for details on the oil fittings.

- **Refrigerant fluid cooled oil cooler**

Picture 11-D¹ shows the diagram of a refrigerant circuit in which the oil is cooled by the refrigerant. An expansion valve controls the flow of refrigerant that cools the oil in the heat exchanger. The oil-refrigerant exchanger must be suitable for the high differences in temperature between the two fluids.

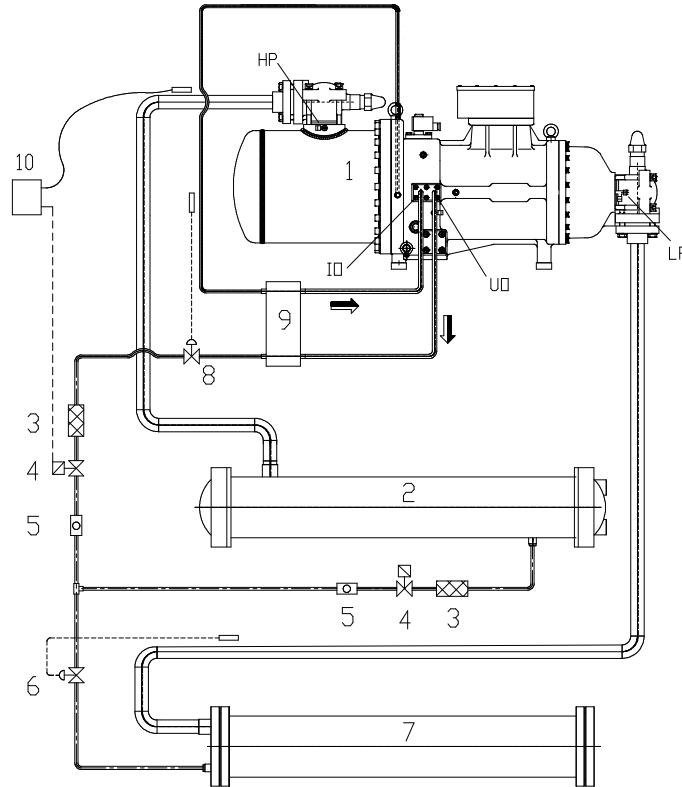

- | | |
|------------------------------|--|
| 1 Compressor; | 7 Evaporator; |
| 2 Condenser; | 8 Oil cooling expansion valve; |
| 3 Filter; | 9 Oil/refrigerant heat exchanger; |
| 4 Solenoid valve; | 10 Thermostat; |
| 5 Sight glass; | IO oil inlet; |
| 6 Thermostatic valve; | UO oil outlet; |

Picture 11-D: oil cooling with oil/refrigerant fluid heat exchanger;

For any further information about this oil cooling method, please contact RefComp.

¹ This is simply a schematic drawing; refer to the drawings of each compressor shown in the paragraph 11-5 for details on the oil fittings and shown in chapter SA-08 in order to locate the actual position for the liquid injection port.

11.5 Position of the oil inlet-outlet connections.

As regards the oil inlet-outlet connections, distinction needs to be made between the new-concept models SRC-XS-40/50/60 and SRC-S-255/285/305 and the remaining models in the SRC-S series.

- **MODELS SRC-XS-40/50/60 AND SRC-S-255/285/305/755/785/885/985.**

To connect the oil cooler, the internal lubrication circuit needs to be modified, changing some parts of the compressor, as shown in Figure 11-E below.

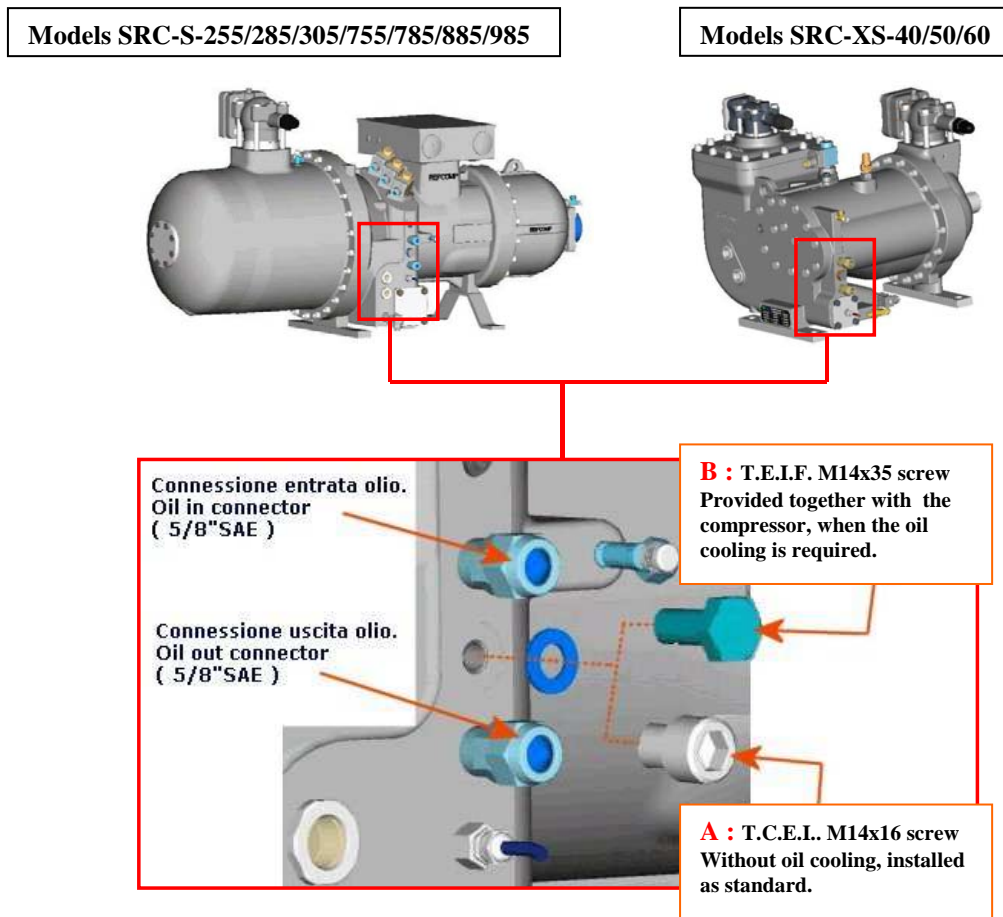

Picture 11. E: oil inlet/outlet connection location for the external oil cooling circuit;

In picture 11.E the part subjected to modification is shown.

The compressor is delivered, in the standard version, with screw A: M14 x 16 fitted on the compressor; in this configuration, the compressor works without the oil cooler. Screw B: M14 x 35 is sent with the compressor, is not fitted and is placed in the electrical box.

In these models, to fit the oil cooler simply replace screw A with screw B and connect the pipes, without needing to use special kits, as is the case with the remaining models in the SRC-S series.

- **MODELS SRC-S-113/133/163/183/213/253/303/353/413/463/503/553/603**

In these models, to make the connection to the cooling circuit, a plate must be replaced, using the kit shown in the next page.

Figures 11-F/G/H below highlight, according to the model, the position on the compressor of the fittings for connection to the external oil cooling circuit.

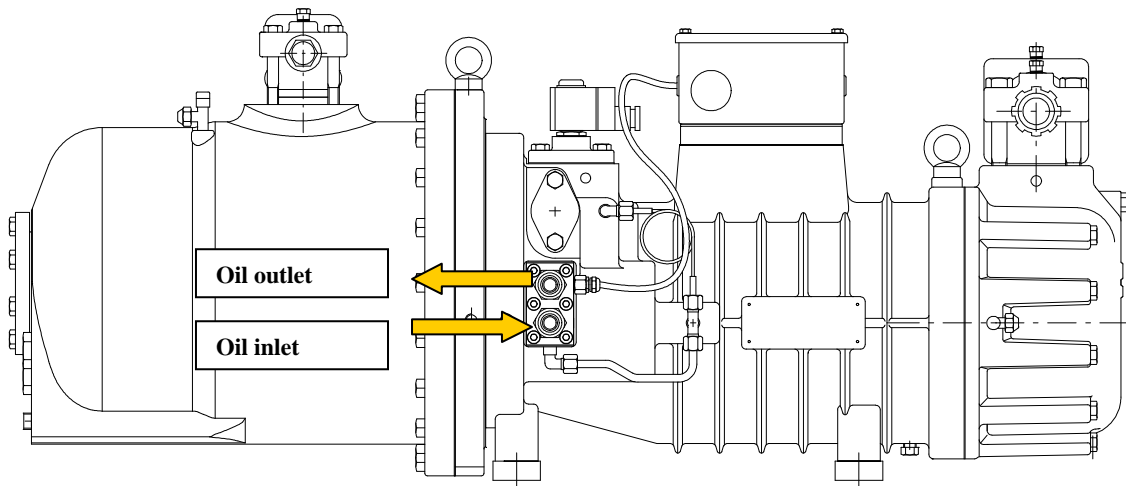

Picture 11-F: Models SRC-S-113/133/163;

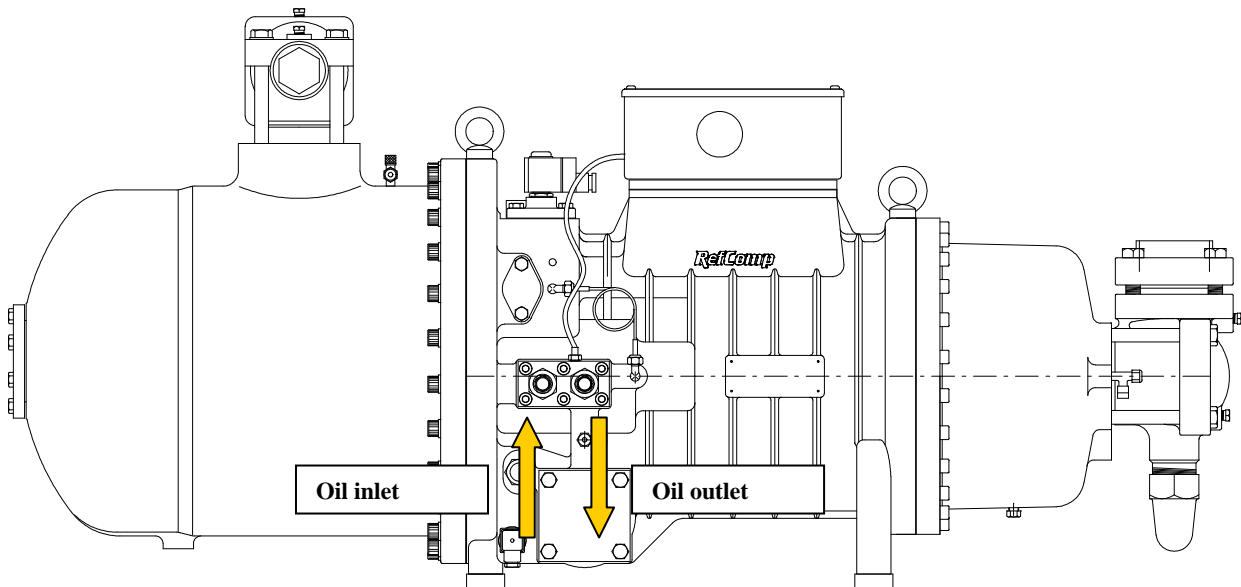

Picture 11-G: Models SRC-S-253/303/353/413/463;

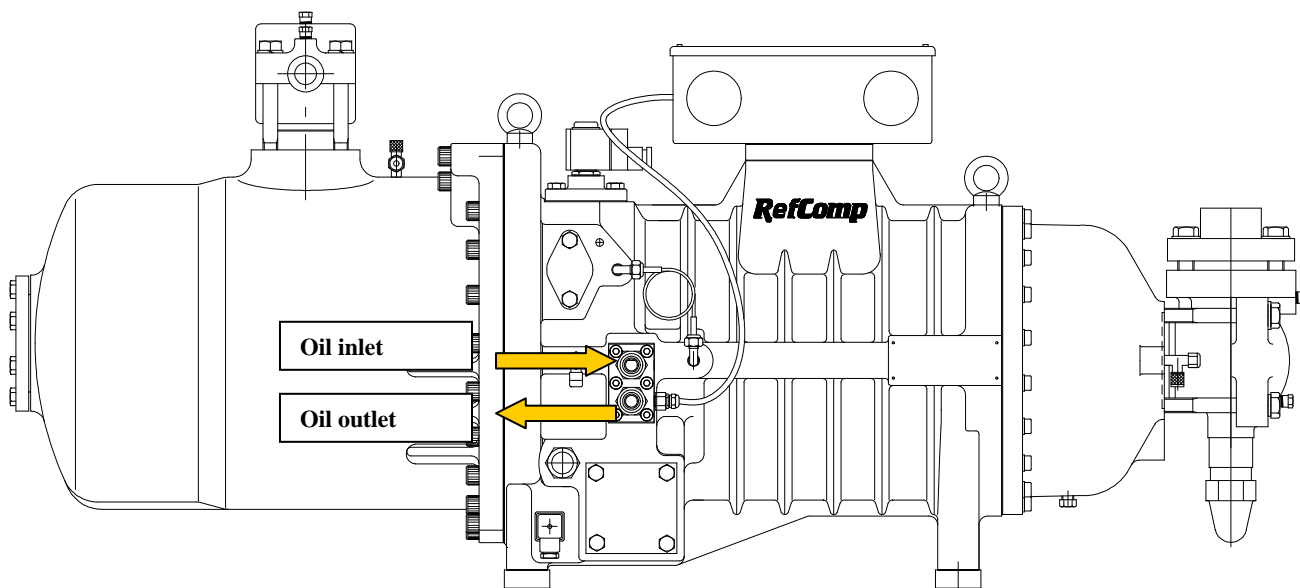

Picture 11-H: Models SRC-S-183/213/503/553/603;

Below is a list of the kits required to make the connection between the compressor and the external cooling circuit, while pictures 11-I/L/M/N show the oil cooling plates, with the various components assembled according to whether the fittings are used or not.

OIL COOLING KIT:

- models SRC-S-113/133/163/183/213/253/303: kit n° 303234

Components: oil inlet pipe coupling	n° 519067
oil cooling plate	n° 519190
kit assembly diagram	n° 585894
plate gasket	n° 592741
cap E.I.	n° 610680
straight fitting	n° 614474
screw 12.9 M8x30	n° 614538
Teflon gasket	n° 691090

- models SRC-S-353/413/463/503/553/603: kit n° 303241

Components: oil inlet pipe coupling	n° 519067
oil cooling plate	n° 519226
kit assembly diagram	n° 585895
plate gasket	n° 592750
cap E.I.	n° 610680
screw 12.9 M10x30	n° 613900
straight fitting	n° 614474
Teflon gasket	n° 691090

- cover plates if the fittings are not used:

SRC-S-113/133/163/183/213/253/303

SRC-S-353/413/463/503/553/603

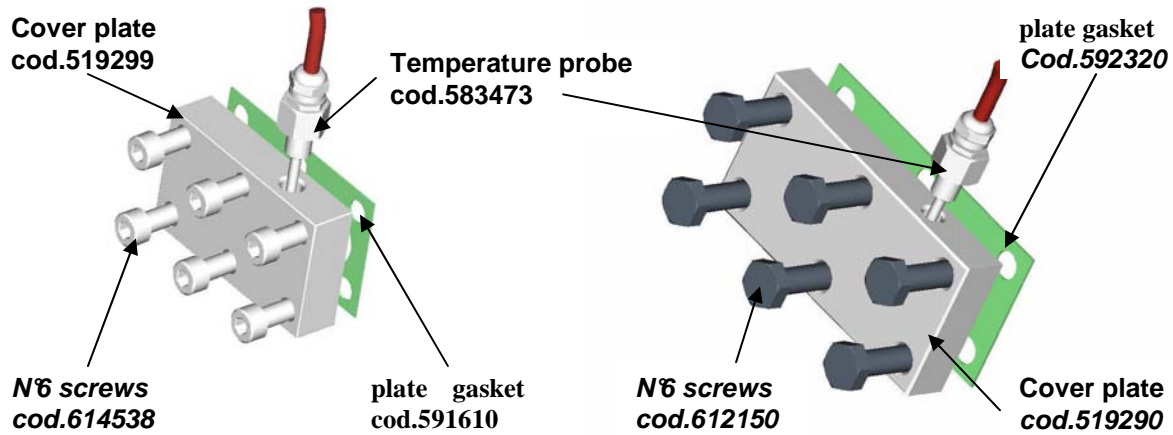

Picture 11-I: cover plate if the fittings for the external oil cooling circuit are not used;

- connection plates if the fittings are used:

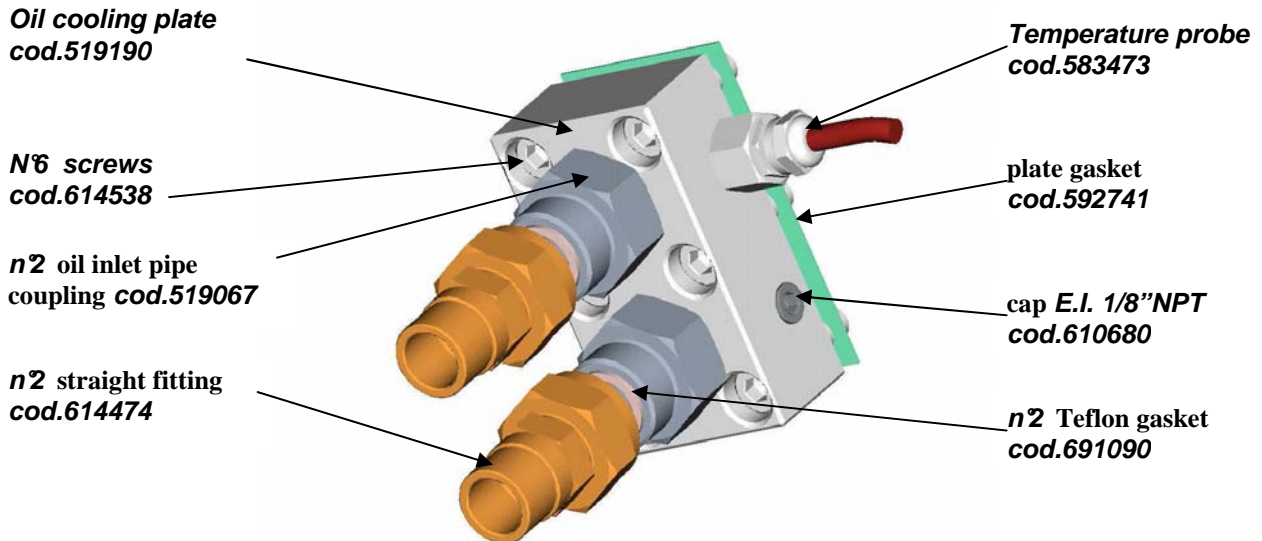

Picture 11-L: plate and fittings assembled for connection to the external oil cooling circuit in models SRC-S-113/133/163;

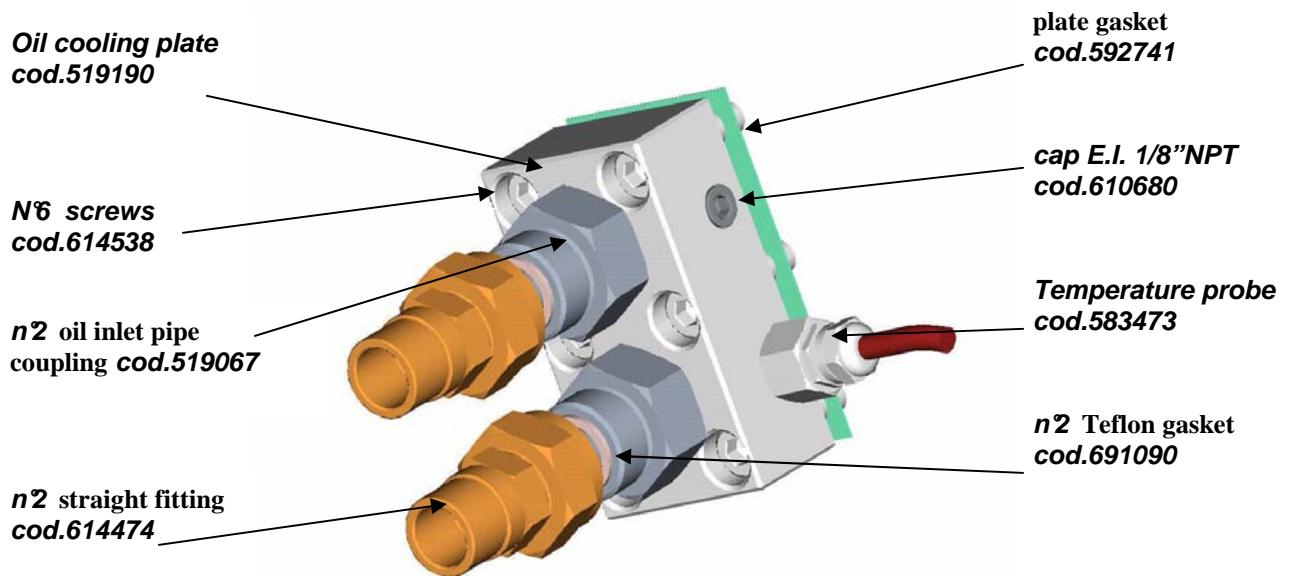

Picture 11-M: plate and fittings assembled for connection to the external oil cooling circuit in models SRC-S-183/213/253/303;

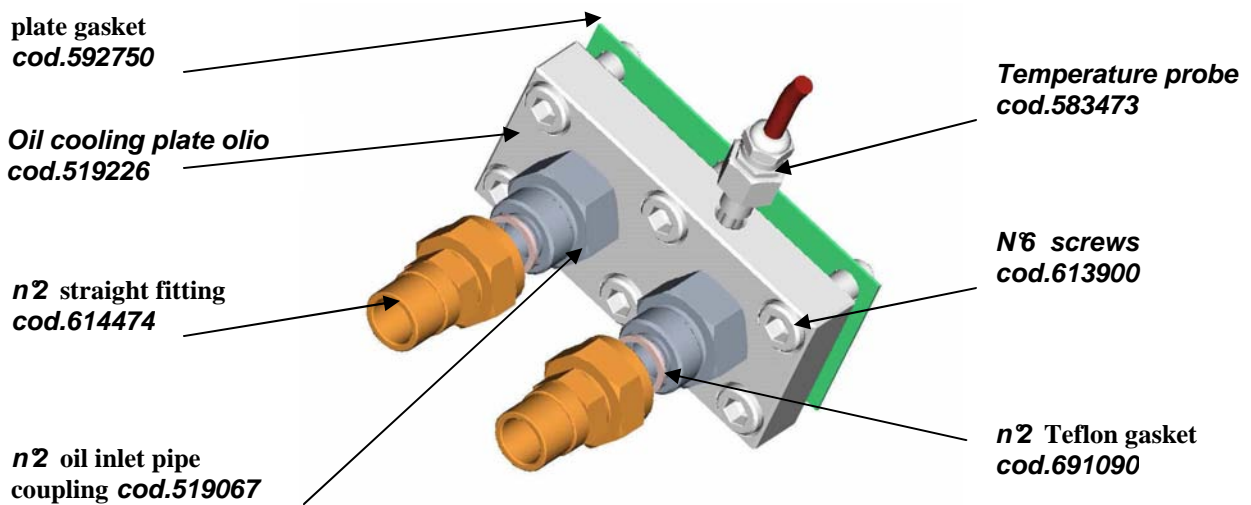

Picture 11-N: plate and fittings assembled for connection to the external oil cooling circuit in models SRC-S-353/413/463/503/553/603;

The previous figure also shows the position on the plate of the temperature probe required to monitor the temperature of the oil, supplied as standard when using the INT 69 RCY protection module, and as an option with the INT 69 VS module. If the probe is not fitted, the bore hole must be closed using the 1/8" NPT screw, code 610680.

SRC-XS and SRC-S series compressors

ECONomizer

(SA-12-04-E)

12	ECONOMIZER	2
12.1	OPERATING PRINCIPLE	2
12.2	COMPONENTS SELECTION	3
12.3	ADDITIONAL SUGGESTIONS	3
12.4	WORKING LIMITS	4

12 ECONomizer

12.1 Operating principle

The economizer, which is an external heat exchanger, sub-cools the liquid leaving the condenser so as to increase the efficiency of the refrigerant cycle. Indeed, with this sub-cooling process the mass flow, that is sent to the evaporator after the expansion, has a lower vapour rate than what would be the case in a normal refrigerating cycle. This entails an increase in the cooling capacity and just a small increase in the power input of the compressor for it has to process the additional mass flow of the economizer circuit. Then an increase in the coefficient of performance is achieved (see picture 12-A¹).

Referring to the same picture, the ECONomizer heat exchanger sub-cools the liquid leaving the condenser with the heat transferred to a flow of refrigerant that is tapped from the liquid line and expanded in a thermostatic valve to the intermediate injection pressure. The superheated vapour leaving the ECO-exchanger is then injected onto the rotors through the economizer port in the compressor, where it mixes with the suction gas, already slightly compressed, coming from the evaporator. The expansion of the tapped liquid flow occurs in the thermostatic valve which, using the bulb located on the ECO-exchanger outlet, controls the correct degree of superheat.

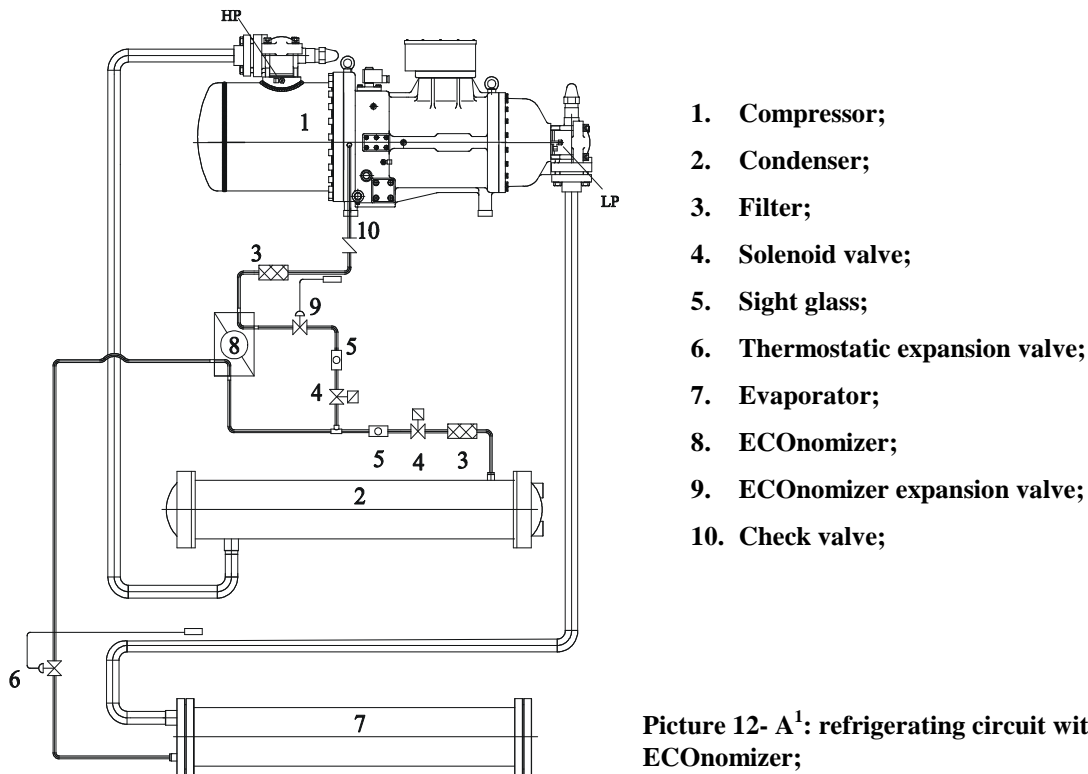

Picture 12- A¹: refrigerating circuit with ECONomizer;

¹ This is simply a schematic drawing; refer to the drawing of each model of compressor for the position of the vapour injection port on the compressor (ECONomizer port).

12.2 Components selection

- **ECO-heat exchanger**

Shell and tube, coaxial tube and brazed plate heat exchangers can be used. The data for sizing the exchanger are given by the RefComp LEONARDO selection software; if this software is not available, please contact RefComp. To avoid injecting liquid onto the rotors, it is recommended to work with the superheat set to around 10 K.

12.3 Additional suggestions

The sub-coolers should be installed below the compressor in order to avoid possible backflows of oil or liquid refrigerant to the compressor during standstill periods. As the compressor may expel a certain quantity of oil through the economizer port when the operating conditions have not yet stabilised or alternatively when the sub-cooling circuit is disabled, the injection pipe should be fitted with an elbow as illustrated in picture 12-B¹. The economizer port leads directly to the rotors, therefore a fine mesh filter (max 25 µm) should be installed. The diameter of the injection pipe should be selected according to Table A.

SRC-XS	40	50	60
Diametro [mm]	22		

SRC-S	113	133	163	183	213	253	255	285	303	305	353	413	463	503	553	603	785	785	885	985
D[mm]	22									28			42		28	42				

Table A: economizer injection pipes diameters;

The following kit must be used for connecting the ECONomizer to its port on the compressor:

- Models SRC-S-113/133/163/183/213: kit n° 303150;

Components: Injection fitting	n° 517740
Teflon gasket	n° 592360
Aluminium washer	n° 613840
Cosval shut off valve	n° 614475
- Models SRC-XS-40/50/60 and SRC-S-253/255/285/303/305: kit n° 303156;

Components: Injection fitting	n° 517740
Teflon gasket	n° 592360
Aluminium washer	n° 613840
Cosval shut off valve	n° 614484
- Models SRC-S-353/413/463: kit n° 303151;

Components: Flange connection	n° 519085
oval flange gasket	n° 591030
Teflon gasket	n° 592360
Cosval shut off valve	n° 614476

¹ This is simply a schematic drawing; refer to the drawing of each model of compressor for the position of the vapour injection port on the compressor (ECONomizer port).

- Models SRC-S-503/553/603: kit n° 303319;

Components: shut off valve	n° 500900
self-adhesive label for spare parts	n° 585600
kit assembly diagram	n° 585899
shut off valve gasket	n° 590790
shut off valve gasket int.	n° 591010
screw grower washer M12	n° 610960
screw 10.9 M12x80	n° 613520

- Models SRC-S-755: kit n° 303572;

Cmponents: Flange connection	n° 511620
Teflon gasket	n° 591020
Assembly scheme	n° 585920
Rotalock connection	n° 501480
Flange oval gasket	n° 591030

- Models SRC-S-785/885/985: kit n° 303883;

Cmponents: Flange connection	n° 511620
Teflon gasket	n° 591020
Rotalock connection	n° 614621
Flange oval gasket	n° 591030

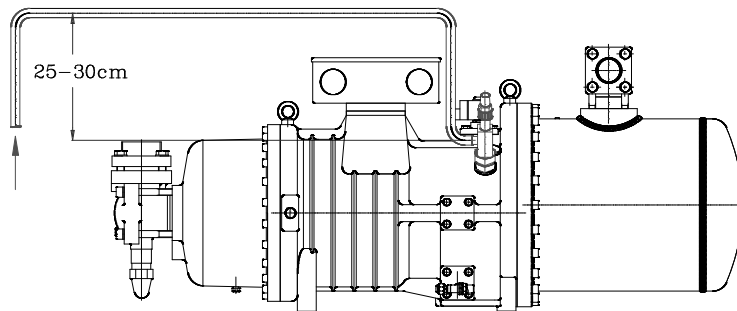

Picture 12- B: Economizer line lay out;

12.4 Working limits

Due to the compression of the additional mass flow (tapping of liquid leaving the condenser) and the consequent overloading of the motor, the operating limits with the economizer are partially more restricted than the standard conditions for the normal operation of the compressor (see chapter SA-10: "Application ranges").

For the models SRC-S-255/285/305 the ECO injection port towards the rotors is located on the slide valve. This way the ECO-circuit can be activated down to 50% load.

The remaining models of the SRC-S series and the SRC-XS-40/50/60 do not feature this special constructional solution and consequently the ECONomizer can only be used to increase the cooling capacity when operating at 100% load.



Warning!

- ✓ For what concerns the models SRC-S-255/285/305, the economiser use is allowed from 50% to 100% load;
- ✓ For the remaining models of the series SRC-S and for the SRC-XS compressor series, the sub-cooling circuit can be used only on full load conditions;
- ✓ During start up, the economiser circuit has to remain disconnected until the working conditions are not stable (the use of a timer to turn on the ECO is recommended).

SRC-XS and SRC-S series compressors

Operative instruction

(SA-13-04-E)

13	OPERATIVE INSTRUCTION	2
13.1	COMPRESSOR LIFTING	2
13.2	AMBIENT OPERATING AND STORAGE TEMPERATURE	2
13.3	SUCTION SUPERHEAT	2
13.4	PRESSURE SPECIFICATIONS	2
13.5	BALANCED PRESSURE WHEN STARTING	3
13.6	MAXIMUM AMBIENT TEMPERATURE	3
13.7	NUMBER OF START-UPS	3
13.8	STARTING, STOPPING AND MINIMUM RUNNING TIME	3
13.9	INSTALLATION	4
13.10	TESTING	4
13.10.1	Leak testing/evacuation/oil charge	4
13.10.2	Refrigerant charge	5
13.11	STARTING	5
13.12	PROTECTION DEVICES INTERVENTION AND TROUBLE SHOOTING	7

13 Operative instruction

13.1 Compressor lifting

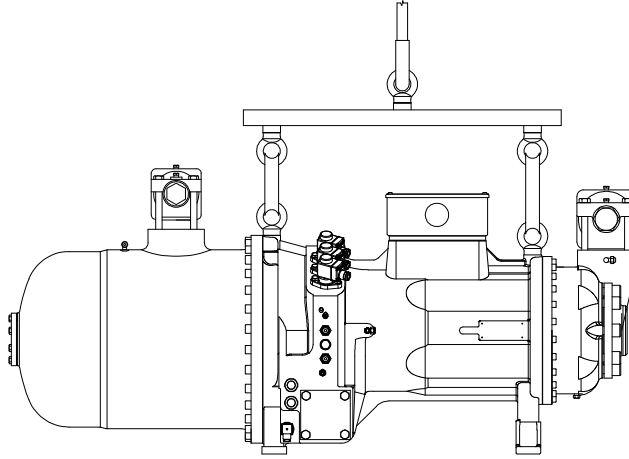

Picture 13-A: anchor points for lifting the compressor;

The compressor can be transported by securing it to a pallet or alternatively lifting it with a suitable cross-beam, using the anchor points highlighted in picture 13-A.

13.2 Ambient operating and storage temperature

The temperature of the environment where the compressor operates and is stored must be between -15°C and $+50^{\circ}\text{C}$.

13.3 Suction superheat

For the compressor the range of admissible suction superheat temperatures is:

R22, R407C and R134a: 5 to 15K (a minimum of 7K is suggested when using R407C refrigerant).



Warning!

When using R407C, the suction superheat is equal to the difference between the suction temperature and the dew point one at the evaporation pressure.

13.4 Pressure specifications

The compressor has the following pressure specifications:

- ✓ Maximum operating pressure: 27.5 bar high pressure side;
- ✓ Maximum balanced pressure: 19 bar high and low pressure sides.

Never operate the compressor at a higher pressure than the maximum operating pressure specified by RefComp and indicated on its plate. The user must ensure also that the balanced pressure does not exceed the maximum value specified by RefComp.

To test the tightness of the compressor, proceed as follows:

- ✓ Test the tightness on low pressure side at 19 bar;
- ✓ Test the tightness on high pressure side at 27.5 bar.

The compressors are designed and tested according to the European standards EN 60335-2-34.

13.5 *Balanced pressure when starting*

In order to generate a starting torque greater than the resisting one, the balanced system pressure (pressure inside the compressor during standstill periods) must not exceed 19 bar.

	<p>Warning! The compressor has to start at minimum capacity step.</p>
--	--

13.6 *Maximum ambient temperature*

During operation, the temperature of the environment where the compressor is working must be kept below the maximum value of 50°C when using the following refrigerants: R22, R407C and R134a (45°C in the case of R404A and R507C). If the compressor is installed in a soundproofed cabinet, suitable ventilation and temperature monitoring systems must be provided.

13.7 *Number of start-ups*

The compressor can be started a maximum of 6 times per hour (1 start every 10 minutes).

	<p>Warning! A number of starts higher than the one suggested may damage the electrical motor and affect the theoretical compressor working life.</p>
--	---

13.8 *Starting, stopping and minimum running time*

The compressor must operate for a minimum time of three minutes. In addition, it must be started and stopped at minimum capacity (minimum step). The transients at minimum load must last 25 seconds at least.

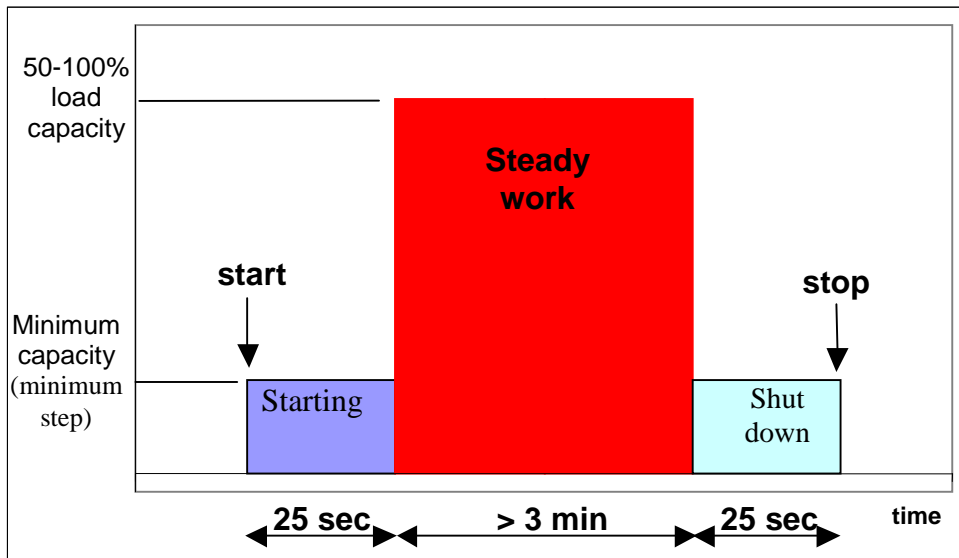

13.9 Installation

The compressor must be installed horizontally. To prevent the compressor from transmitting vibrations to the structure, the vibration damper kit should be used. It is supplied as an option. Flexible pipes are not required on the suction or discharge lines. Only minimum flexibility of the lines is required, so that these do not exert any force on the compressor.

Please use pipes and components that are extremely clean and dry inside, without slag, swarf, rust and phosphate coating.

When operating in extreme conditions, such as low ambient temperatures or aggressive atmospheres, suitable measures should be adopted. Please contact RefComp.

- **Heat pumps**

	<p>Warning!</p> <p>Reverse cycle systems or hot gas defrosts require suitable measures to protect the compressor against:</p> <ul style="list-style-type: none"> ✓ Liquid slugging; ✓ Increase in oil carry over, which determines a consequent decrease in the oil level inside the compressor; ✓ Operation with a reduced Δp (HP-LP), and a consequent reduction in lubrication.
---	---

To protect the compressor against liquid slugging, a suction accumulator should be installed. To prevent excessive oil carry over (due to a rapid decrease in pressure in the oil separator), make sure that the temperature of the oil during the reverse cycle procedure is at least 30-40 K above the condensing temperature. It may be necessary to install a pressure regulating valve downstream the compressor to limit the drop in pressure during reverse cycle and defrost operation. The compressor can also be stopped just before reversing the cycle and then started again after the pressure has balanced. In any case the compressor should work within the specified range of pressures and within the operating limits, as well as with the recommended protectors, within a maximum of 20 seconds from starting (see chapter SA-02: “*Lubrication*”).

13.10 Testing

13.10.1 Leak testing/evacuation/oil charge

	<p>Note:</p> <p>The compressors are supplied with a protective nitrogen charge (0.5-1 bar above atmospheric pressure) to prevent air from entering inside.</p>
---	---

Perform the leak test on the refrigerant circuit with dry nitrogen; if the circuit is tested with dry air, the compressor must be bypassed. Empty the entire circuit, including the compressor and the sections isolated by the valves, both on the suction side and on the discharge side. The vacuum required is at least 1.5 mbar (with isolated vacuum pump); if necessary repeat the operation more than once. After emptying, add the oil to the compressor, if the oil charge is supplied separately, and switch on the oil heater.

As regards the compressor, this has already been tested for leaks under pressure, and therefore this test does not need to be performed by the user. If the leak test does need to be repeated by the user, make sure the design pressures reported on the compressor rating plate are never exceeded (see paragraph 13-4: "Pressure specifications").

	<p>Warning!</p> <ul style="list-style-type: none">✓ Never subject the compressor to pressure higher than the design values indicated on the rating plate;✓ Never start the compressor under vacuum.
---	---

13.10.2 Refrigerant charge

Charge the liquid refrigerant directly into the receiver and into the condenser, and complete the charge on the suction side during operation. To avoid liquid backflow when the refrigerant is charged in the liquid phase (always necessary with R407C) verify that the discharge temperature is around 30K (generic value, purely indicative) above the condensing temperature. An insufficient charge causes a low suction pressure and a high superheat (observe the chapter SA-10: "Application limits").

To identify the correct discharge temperature, use the RefComp LEONARDO selection software.

13.11 Starting

STARTING:

- ✓ After discharging the protective nitrogen charge, connect the compressor to the plant, making sure that the shut-off valves are closed. This avoids contact between the humidity of the air and the oil. However if the oil comes into contact with the humidity, it must be for not longer than 30 min;
- ✓ Make all the electrical connections as given in the wiring diagram on chapter SA-05: "Electrical devices";
- ✓ Perform the following preliminary checks:
 - Correct setting of the start timers;
 - Oil level;
 - Correct safety and protection devices setting and functioning;
 - Correct functioning of the high and low pressure switches;
 - Look for leakage along the piping and system components;
- ✓ Turn on the oil heater at least 24 hours before each first seasonal start-up. The oil inside the separator must have a temperature at least 15K higher than the ambient temperature;
- ✓ Charge the condenser with the minimum refrigerant charge;
- ✓ Open the suction and discharge shut off valves and start the compressor while checking the correct motor rotation in the following way (even if some protection electronic device is used):
 - Connect a manometer on the suction port;
 - Start for 1 second max;
 - If the compressor screws rotate correctly, the suction pressure will drop promptly. The electronic protection intervention or a suction pressure increase implies the wrong rotors rotation. In this case, switch two of the power supply phases in the terminal plate.



Warning!

To prevent severe damage of the compressor, a contingent screw inverse rotation should last for less than 3 sec.

START:

- ✓ Fill up the plant with the necessary amount of refrigerant;
- ✓ Re-start the compressor and open slowly the suction shut-off valve;
- ✓ Make sure that the oil level is visible through the sight glass. Presence of foam is normal as long as the working conditions are not stable. The discharge temperature must be about 30K higher than the condensing temperature;



Warning!

The presence of foam, even in stable operating conditions, can be considered normal with CP-4214-320 oil and R22 refrigerant.

- ✓ Check the correct intervention for the pressure switches;
- ✓ Check the working parameters (data logging is recommended):
 - Evaporating pressure;
 - Condensing temperature;
 - Suction gas temperature;
 - Discharge temperature;
 - Pressure drop through the oil filter;
 - Contingent unbalanced electrical absorbed currents on all the 6 wires connected to the electricity grid.
- ✓ Change the oil filter if dirty (see chapter SA-02: “*Lubrication*”).

13.12 Protection devices intervention and trouble shooting

Failure	Protection devices	Why it is necessary	Delivery
Incorrect phase sequence	Phase monitor	The compressor should not work with inverse rotation	INT 69 RCY (optional)
High discharge pressure	Manual pressure switch	To avoid an excessive pressure increase in the compressor	necessary, not included
high temperature of motor windings	thermistors embedded in the motor windings (cut out 100/120° C)	To protect the motor from high temperatures	standard
too high motor current	Thermal Relay	To protect motor from electrical overload	necessary, not included
low suction pressure	pressure switch	insufficient refrigerant charge (high pressure ratio, high disch.temp.)	necessary, not included
low differential pressure HP/LP	HP/LP differential pressure switch (cut out 4 bar min)	To grant a sufficient oil flow	necessary, not included
high oil discharge temperature	Additional cooling (liquid injection / oil cooling)	To ensure a long bearing life	mandatory if required by the working conditions
lack of lubrication	discharge gas temperature sensor (cut out 120° C)	To protect the compressor from lack of lubrication	temperature sensor: optional with INT 69 VS and standard with INT 69 RCY
too high pressure drop in the oil filter	differential pressure switch (cut out 1.5 or 3.5 bar, see chapter SA-02 and SA-10)	To ensure cleanness of oil filter	necessary, not included
too frequent compressor starts	limit of starts (max 6 per hour)	To protect the electrical motor	necessary, not included

SRC-XS and SRC-S series compressors
Maintenance
(SA-14-04-E)

14. MAINTENANCE

2

14. Maintenance

- LUBRICANTS.

The lubricants have high thermal and chemical stability: if installation is performed correctly, the oil normally does not need to be changed. Periodically test the acidity of the oil to prevent damage to the motor or the compressor and, if necessary, perform the following operations:

- ✓ clean the circuit placing an acid filter in the suction line;
- ✓ change the oil and the oil filter;
- ✓ purge the system from the highest point on the discharge side.

The oil can be drained through the service valve and the plug on the bottom of the suction cover (see chapter SA-02: “*Lubrication*”). The oil can be recharged through the service valve, creating a vacuum inside the compressor.

- BEARINGS.

The bearings in the compressor are designed to ensure 40,000 hours of operation with correct lubrication (oil filter clean and oil pressure within the limits, see paragraph SA-02: ‘*Lubrication*’) and continuous load within the limits specified in chapter SA-10: “*Application range*”. Any alteration of the above-mentioned conditions and excessive changeability of the load may bring a drastic reduction in the effective working life. The bearings must be replaced by qualified personnel in a specially equipped workshop.

- ROTORS ROTATION DIRECTION.

If the reverse rotation, which occurs when the compressor stops to balance the pressure, lasts more than 3 seconds, the check valve located underneath the discharge shut-off valve may be damaged, and consequently must be replaced. In any case, the reverse rotation must not last more than 5 seconds to avoid damage to the compressor and the unwanted activation of the INT 69 RCY protection module.

On table A, necessary check outs and maintenance operations are listed:

Time (h)	50-100	1000	10000	20000	30000	40000
Oil filter	C/S					S
Oil	C	C	C	C	C	S
Suction filter		C	C		C	C
Solenoid valves		C	C	C	C	C
Bearings						S
Check valve		C	C	C	C	C
INT module		C	C	C	C	C
Feeding voltage	C	C	C	C	C	C
Motor contactors		C	C	C	C	C

S = substitute C = check

Table A: maintenance plan;

SRC-XS and SRC-S series compressors
Capacity control conversion
(SA-15-03-E)

15 CAPACITY CONTROL CONVERSION.	2
15.1 CAPACITY CONTROL CONVERSION IN MODELS SRC-S-113/133/163/183/213/253/303/353/413/ 463/503/553/603.	3
15.1.1 Conversion from STEP (L4) to INFINITE (LZ) capacity control	3
15.1.2 Operating instructions for converting from the step to the infinite configuration	5
15.1.3 Conversion from INFINITE (LZ) to STEP (L4) capacity control	7
15.1.4 Operating instructions for converting from the infinite to the step configuration	9
15.2 CAPACITY CONTROL CONVERSION IN MODELS SRC-S-255/285/305/755.	11
15.3 CAPACITY CONTROL CONVERSION IN MODELS SRC-S-785/885/985	13

15 CAPACITY CONTROL CONVERSION.

As already mentioned in chapter SA-03: “*Capacity control*”, the conversion between step and stepless configurations is performed differently for the new-concept models SRC-S-255/285/305 and the remaining models in the SRC-S series. In the new three models, in fact, just one plate needs to be changed, while in the others one, the external capillary tube needs to be changed, suitable calibrated orifices have to be installed and the position of one of the three solenoid valves used for capacity control has to be changed. The procedures for the two types of SRC-S series compressors are described separately.

For what concerns the SRC-XS series compressors, they are defined by a single configuration: the “L2” three steps configuration (100-75-50%) and therefore they are not subjected to any conversion.



Warning!

- ✓ All the required operations to change the capacity control, must be done without pressure inside the compressor;
- ✓ After the configuration change, the refrigerant is charged inside the compressor by setting the compressor on vacuum;
- ✓ All operations must be carried out by expert personnel.

With reference to the following pictures, the conversion from “L4” to “LZ” is achieved by changing the position of solenoid valve 16 with the cover flange located in position 19. In the LZ configuration, then, this solenoid valve is identified by number 19 and no longer by 16. In addition, you have to replace the capillary tube already installed on the compressor with the new one included in the conversion kit and you have to install the given calibrated orifices. The operating instructions are shown in the following pages.

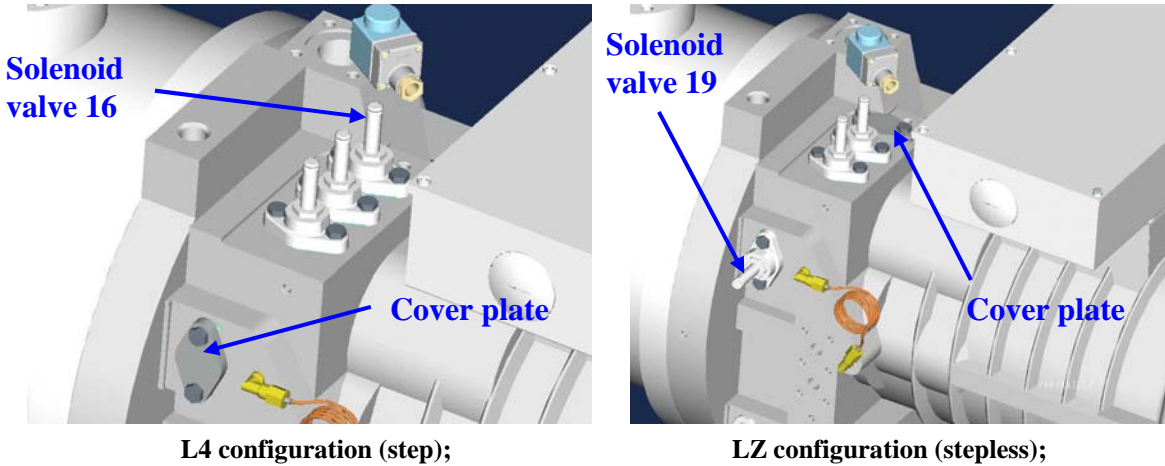

L4 configuration (step);

LZ configuration (stepless);

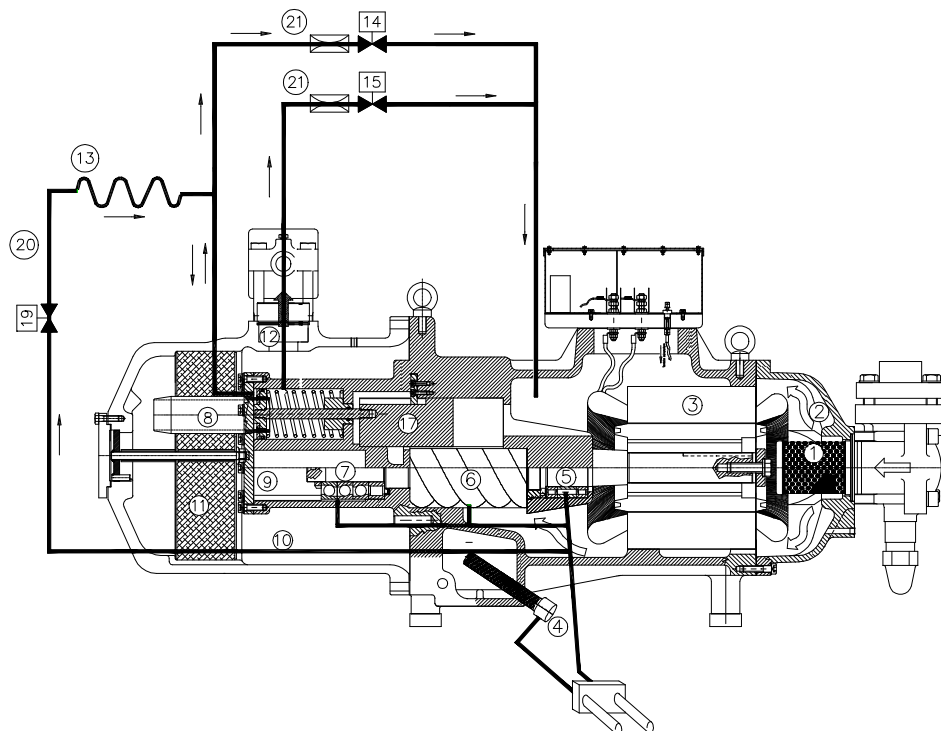

oil circuit layout in the LZ configuration;

21: calibrated orifices;

13: capillary tube;

14. 15 and 19: solenoid valves.

15.1.2 Operating instructions for converting from the step to the infinite configuration

- 1- Remove solenoid valve 16 and the cover flange;
- 2- In place of solenoid valve 16, fit the cover flange inserting the gasket -code 592731- included in the conversion KIT;

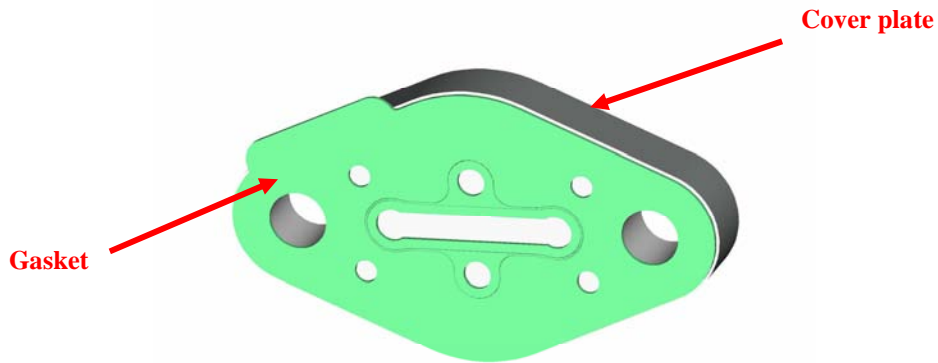

- 3- Fit the solenoid valve in the new position 19, with the inserted gasket -code 592731- included in the conversion KIT;

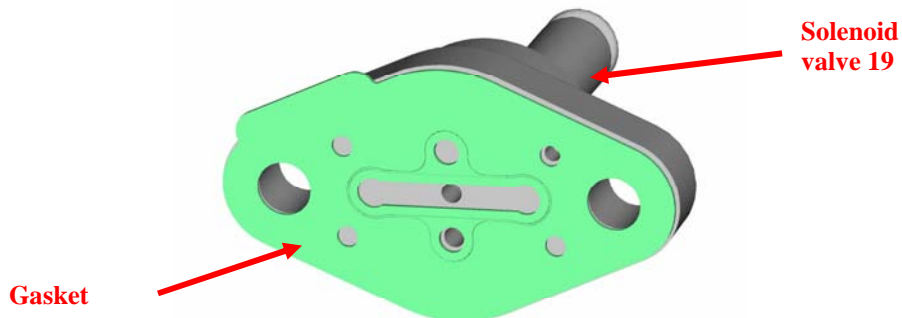

- 4- Remove solenoid valves 14 and 15 and tighten the two calibrated orifices to the casing;

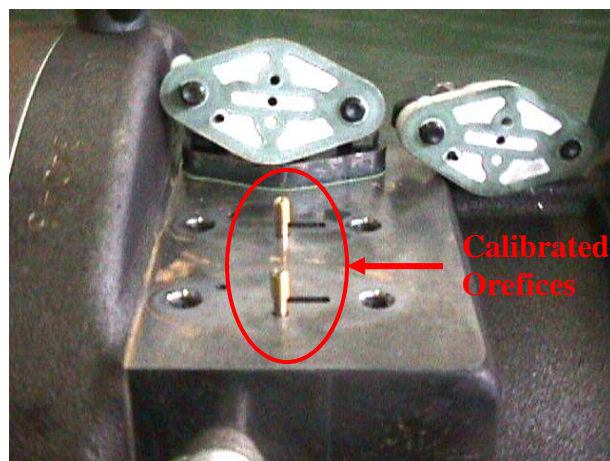

- 5- Replace solenoid valves 14 and 15 in the same position, inserting the gaskets -code 592731;

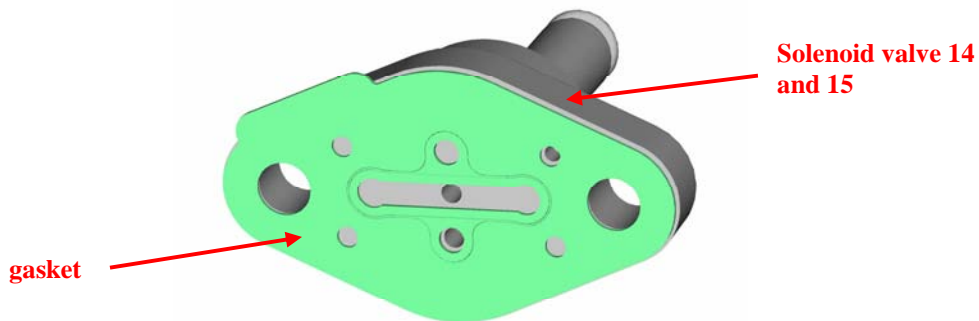

- 6- Replace the capillary tube with the new one -code 540684- included in the kit;



15.1.3 Conversion from INFINITE (LZ) to STEP (L4) capacity control

The special conversion kit (code 303202) is used to perform the conversion from the INFINITE to the STEP configuration.

The kit consists of the following components:

- 1) n°3 GASKETS for solenoid valves, code 592731;

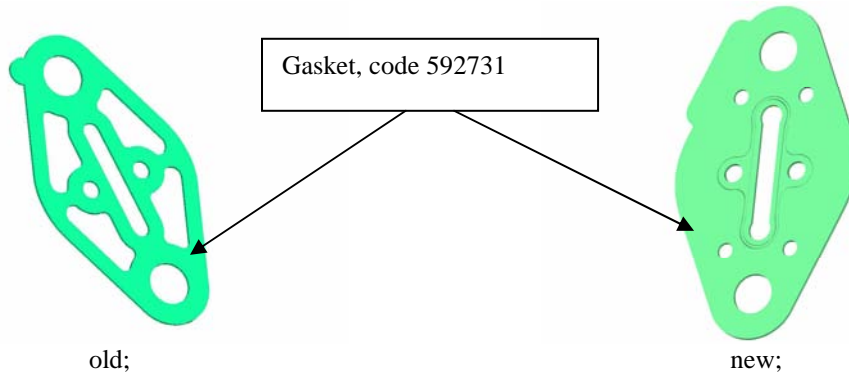

- n°1 GASKET for cover flange, code 592732.

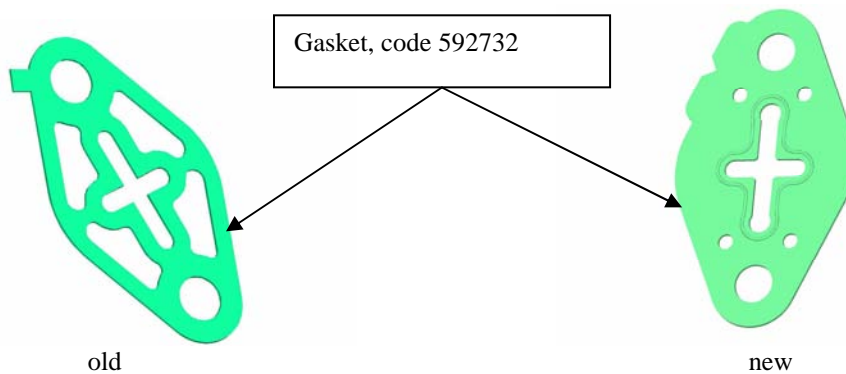

- 2) n°1 CAPILLARY tube, complete with nuts, code 540701;

NOTE: the capillary tube installed in the “L4” version is larger than the one used in the “LZ” version.

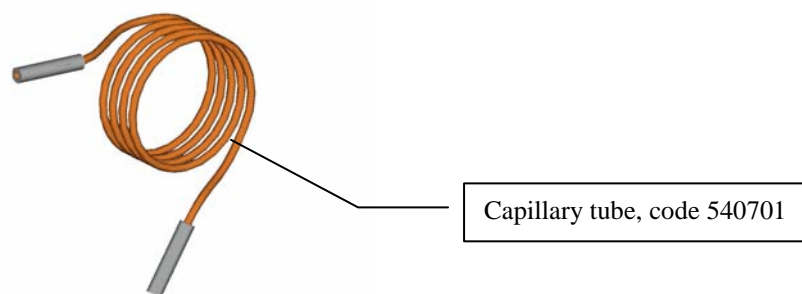

With reference to the pictures of the following page, the conversion from “LZ” to “L4” is performed by changing the position of solenoid valve 19 with the cover flange, now located on top of the compressor, next to the other two solenoid valves. In the L4 configuration, therefore, this solenoid valve will be identified again by the number 16 and the cover flange will return to its original position (19) of the L4 configuration. In addition, replace the capillary tube already installed in the compressor with the new one included in the conversion kit and remove the calibrated orifices. The operating instructions are shown in the following page.

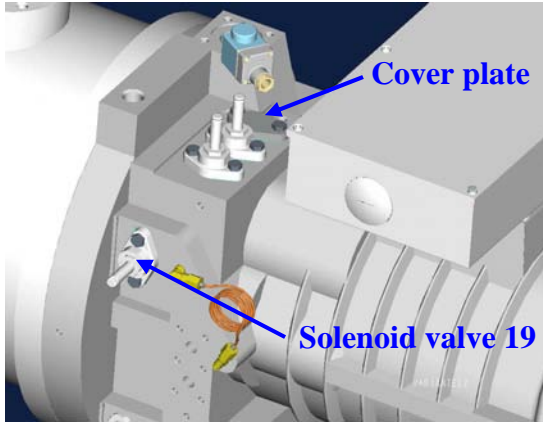

LZ configuration (stepless);

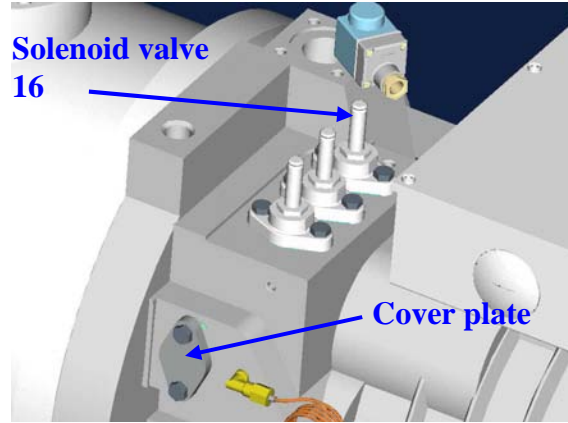

L4 configuration (step);

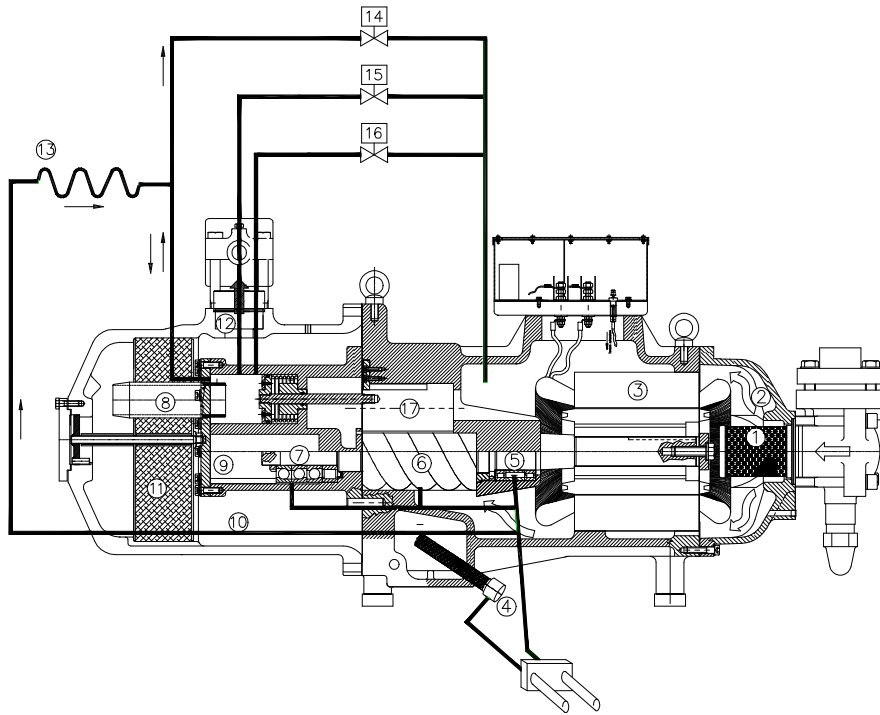

**oil circuit layout in the L4 configuration;
 13: capillary tube;
 14, 15 and 16: solenoid valves.**

15.1.4 Operating instructions for converting from the infinite to the step configuration

1. Remove solenoid valve 19 and the cover flange;
2. In place of the cover flange, fit the solenoid valve after inserting the gasket -code 592731- included in the conversion kit;

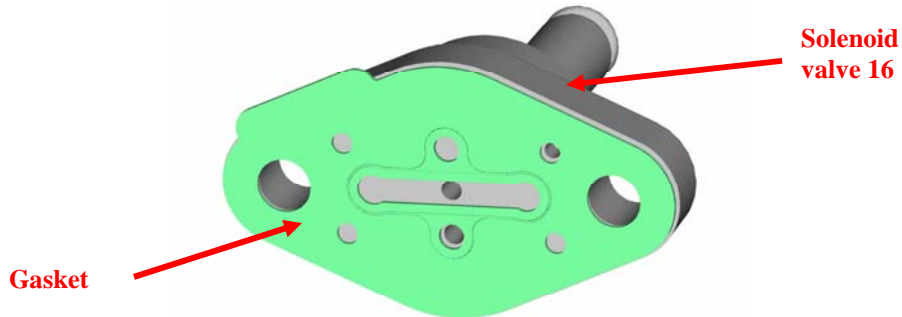

3. In the position 19 fit the cover flange, after inserting the gasket -code 592732- included in the conversion kit;

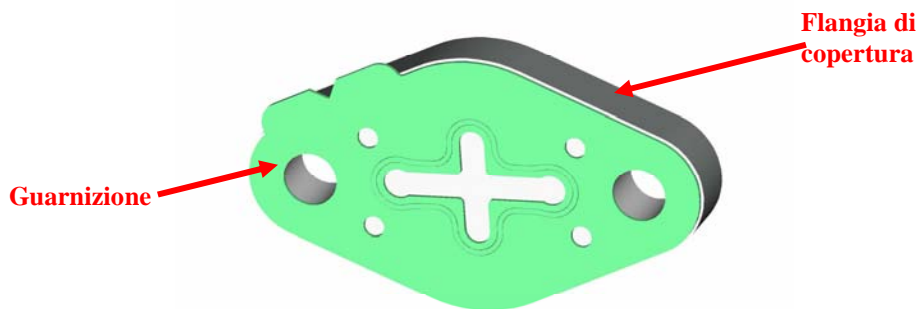

4. Remove the orifices positioned underneath the solenoid valves 14 and 15;



5. Replace the solenoid valves 14 and 15 in their original position, after inserting the gaskets -code 592731;

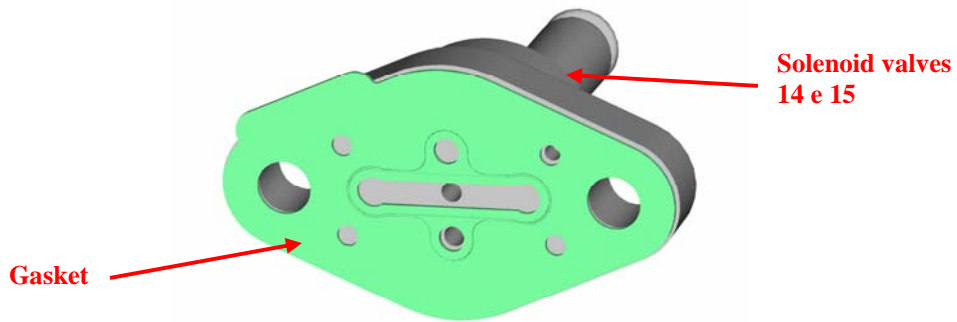

6. Change the capillary tube with the new one -code 540701- included in the conversion kit;

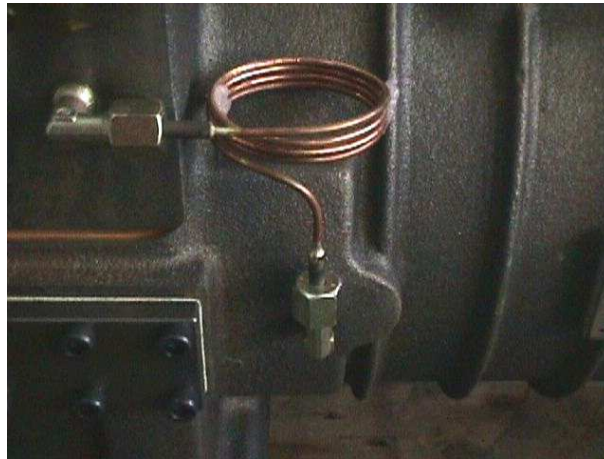

15.2 CAPACITY CONTROL CONVERSION IN MODELS SRC-S-255/285/305/755.

In models 255/285/305/755, the step and stepless configurations can be changed simply by using different special-shape plates, which modify the configuration of the internal oil circuit (see chapter SA-03: ‘Capacity control’, paragraphs 3.1.2 and 3.1.4).

Below is a description of the conversion kits and their components.

KIT FOR CONVERTING FROM THE STEP TO THE STEPLESS CONFIGURATION: Code 303559.

Components:

- Code: 519423 “LZ” capacity control plate;
- Code: 585918 capacity control conversion diagram;
- Code: 592731 Solenoid valve gasket;
- Code: 592762 Solenoid valve gasket / capacity control plate;
- Code: 614566 Elastic pin d=3x8 DIN 7346 UNI 68;

KIT FOR CONVERTING FROM THE STEPLESS TO THE STEP CONFIGURATION: Code 303558.

Components:

- Code: 519422 “L4” capacity control plate;
- Code: 585918 capacity control conversion diagram;
- Code: 592731 Solenoid valve gasket;
- Code: 592762 Solenoid valve gasket / capacity control plate;
- Code: 614566 Elastic pin d=3x8 DIN 7346 UNI 68;

The following page reports the necessary instructions and the assembly diagram of the various components required to replace the two plates and perform the conversion.



Warning:

- ✓ As shown in the following page, the two plates have a different external profile. This means that the type of the applied capacity control can be easily identified all the times.

Conversion base plate "L4-LZ"

Hole for the pin on the solenoid valve side
Piastrina "LZ"
cod.519423

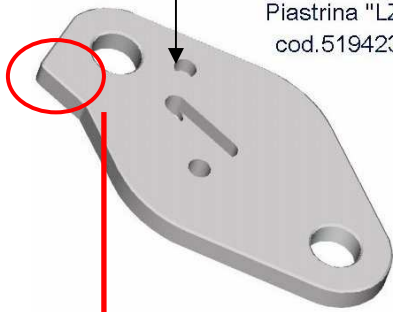

Piastrina "L4"
cod.519422

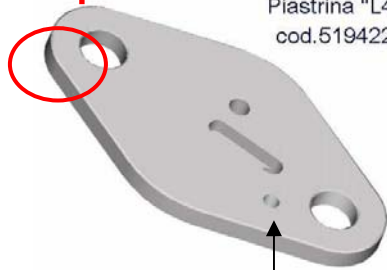

Hole for the pin on the solenoid valve side

Position of the plate: underneath the solenoid valve (16);

Main unloading components

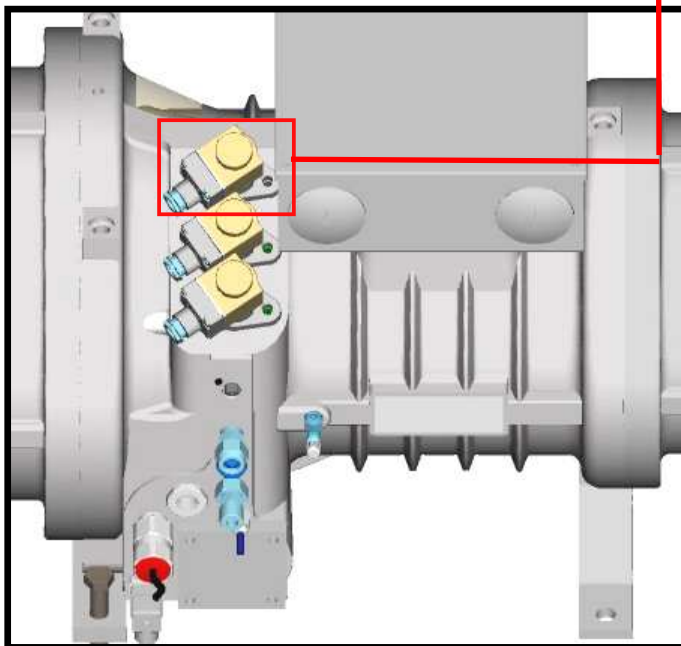
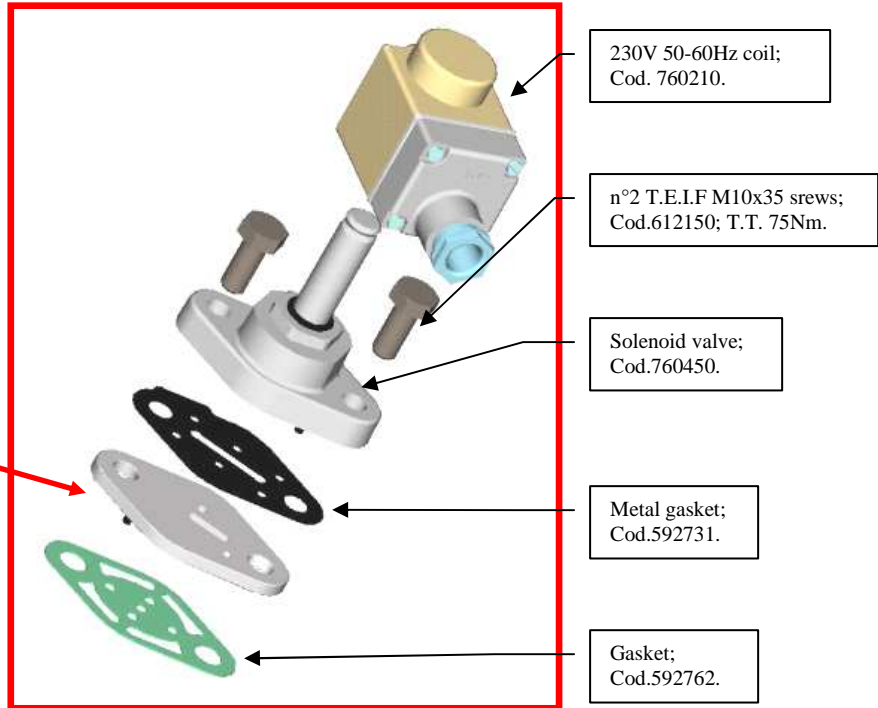

To convert the compressor lay-out from the stepped "L4" to the stepless "LZ" capacity control configuration, replace the plate code 519422 with the plate code 519423. Vice-versa you will perform the opposite switch.

NB.:
Please, install the electro-valve correctly by matching the base plate pin / case hole and electro-valve pin/base plate hole

15.3 CAPACITY CONTROL CONVERSION IN MODELS SRC-S-785/885/985

Plate L4

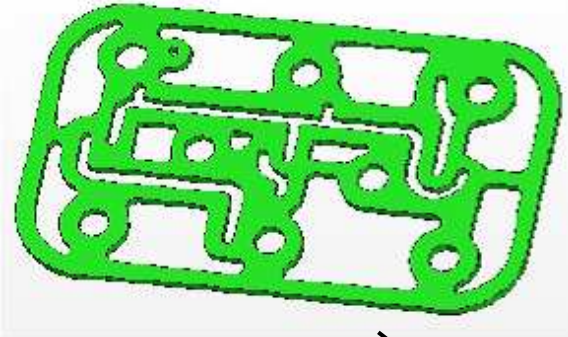
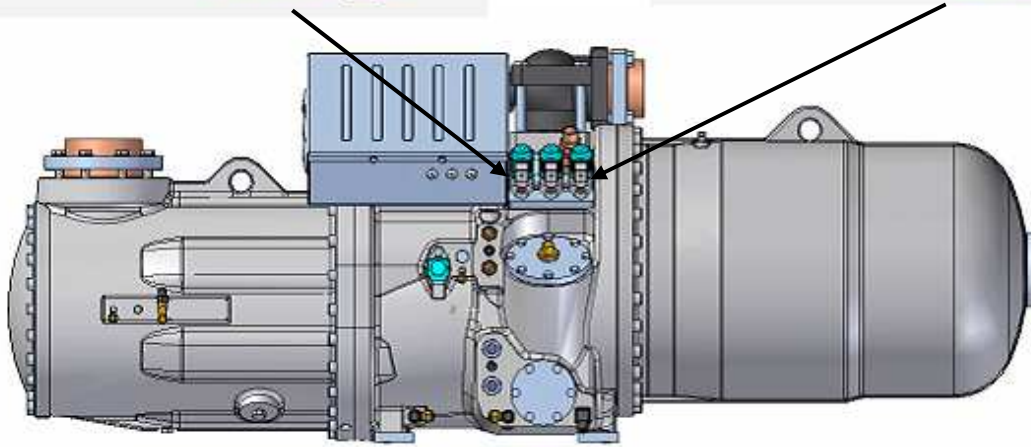
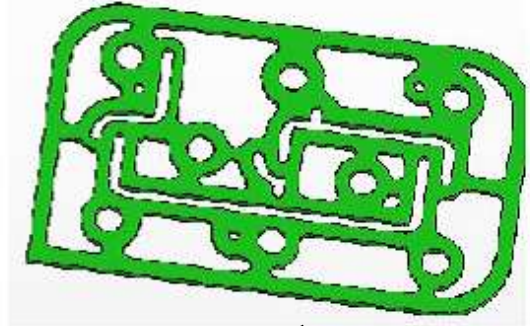

Plate LZ



To convert the compressor lay-out from the stepped “L4” to the stepless “LZ” capacity control configuration, replace the plate code 592833 with the plate code 592832. Vice-versa you will perform the opposite switch.